

European science review

Nº 3–4 2018

March–April

European Sciences review

Scientific journal

№ 3–4 2018 (March–April)

ISSN 2310-5577

Editor-in-chief

Lucas Koenig, Austria, Doctor of Economics

International editorial board

Abdulkasimov Ali, Uzbekistan, Doctor of Geography
Adieva Aynura Abduzhalalovna, Kyrgyzstan, Doctor of Economics
Arabaev Cholponkul Isaevich, Kyrgyzstan, Doctor of Law
Zagir V. Atayev, Russia, Ph.D. of Geographical Sciences
Akhmedova Raziya Abdullayevna, Russia, Doctor of Philology
Balabiev Kairat Rahimovich, Kazakhstan, Doctor of Law
Barlybaeva Saule Hatiyatovna, Kazakhstan, Doctor of History
Bestugin Alexander Roaldovich, Russia, Doctor of Engineering Sciences
Boselin S.R. Prabhu, India, Doctor of Engineering Sciences
Bondarenko Natalia Grigorievna, Russia, Doctor of Philosophy
Bogolib Tatiana Maksimovna, Ukraine, Doctor of Economics
Bulatbaeva Ayyul Abdimazhitovna, Kazakhstan, Doctor of Education
Chiladze George Bidzinovich, Georgia, Doctor of Economics, Doctor of Law
Dalibor M. Elezović, Serbia, Doctor of History
Gurov Valeriy Nikolaevich, Russia, Doctor of Education
Hajiyev Mahammad Shahbaz oglu, Azerbaijan, Doctor of Philosophy
Ibragimova Liliya Ahmatyanovna, Russia, Doctor of Education
Blahun Ivan Semenovich, Ukraine, Doctor of Economics
Ivannikov Ivan Andreevich, Russia, Doctor of Law
Jansarayeva Rima, Kazakhstan, Doctor of Law
Khubaev Georgy Nikolaevich, Russia, Doctor of Economics
Khurtsidze Tamila Shalvovna, Georgia, Doctor of Law
Khoutyz Zaur, Russia, Doctor of Economics
Khoutyz Irina, Russia, Doctor of Philology
Korz Marina Vladimirovna, Russia, Doctor of Economics

Kocherbaeva Aynura Anatolevna, Kyrgyzstan, Doctor of Economics
Kushaliyev Kaisar Zhalitovich, Kazakhstan, Doctor of Veterinary Medicine
Lekerova Gulsim, Kazakhstan, Doctor of Psychology
Melnichuk Marina Vladimirovna, Russia, Doctor of Economics
Meymanov Bakyt Kattoevich, Kyrgyzstan, Doctor of Economics
Moldabek Kulakhmet, Kazakhstan, Doctor of Education
Morozova Natalay Ivanovna, Russia, Doctor of Economics
Moskvin Victor Anatolevich, Russia, Doctor of Psychology
Nagiye Polad Yusif, Azerbaijan, Ph.D. of Agricultural Sciences
Naletova Natalia Yurevna, Russia, Doctor of Education
Novikov Alexei, Russia, Doctor of Education
Salaev Sanatbek Komiljanovich, Uzbekistan, Doctor of Economics
Shadiev Rizamat Davranovich, Uzbekistan, Doctor of Education
Shahhutova Zarema Zorievna, Russia, Ph.D. of Education
Soltanova Nazilya Bagir, Azerbaijan, Doctor of Philosophy (Ph.D. of History)
Spasennikov Boris Aristarkhovich, Russia, Doctor of Law
Spasennikov Boris Aristarkhovich, Russia, Doctor of Medicine
Suleymanov Suleyman Fayzullaevich, Uzbekistan, Ph.D. of Medicine
Suleymanova Rima, Russia, Doctor of History
Tereschenko-Kaidan Liliya Vladimirovna, Ukraine, Doctor of Philosophy
Tersvadze Mzia Giglaevna, Georgia, Doctor of Philology
Vijaykumar Muley, India, Doctor of Biological Sciences
Yurova Kseniya Igorevna, Russia, Ph.D. of History
Zhaplova Tatiana Mikhaylovna, Russia, Doctor of Philology
Zhdanovich Alexey Igorevich, Ukraine, Doctor of Medicine

Proofreading

Kristin Theissen

Cover design

Andreas Vogel

Additional design

Stephan Friedman

Editorial office

Premier Publishing s.r.o. Praha 8 – Karlín, Lyčkovo nám. 508/7, PŠČ 18600

E-mail:

pub@ppublishing.org

Homepage

ppublishing.org

European Journal of Arts is an international, German/English/Russian language, peer-reviewed journal. It is published bimonthly with circulation of 1000 copies.

The decisive criterion for accepting a manuscript for publication is scientific quality. All research articles published in this journal have undergone a rigorous peer review. Based on initial screening by the editors, each paper is anonymized and reviewed by at least two anonymous referees. Recommending the articles for publishing, the reviewers confirm that in their opinion the submitted article contains important or new scientific results.

Premier Publishing s.r.o. is not responsible for the stylistic content of the article. The responsibility for the stylistic content lies on an author of an article.

Instructions for authors

Full instructions for manuscript preparation and submission can be found through the Premier Publishing s.r.o. home page at: <http://www.ppublishing.org>.

Material disclaimer

The opinions expressed in the conference proceedings do not necessarily reflect those of the Premier Publishing s.r.o., the editor, the editorial board, or the organization to which the authors are affiliated.

Premier Publishing s.r.o. is not responsible for the stylistic content of the article. The responsibility for the stylistic content lies on an author of an article.

Included to the open access repositories:



The journal has the GIF impact factor 1.26 for 2017.

© Premier Publishing s.r.o.

All rights reserved; no part of this publication may be reproduced, stored in a retrieval system, or transmitted in any form or by any means, electronic, mechanical, photocopying, recording, or otherwise, without prior written permission of the Publisher.

Typeset in Berling by Ziegler Buchdruckerei, Linz, Austria.

Printed by Premier Publishing s.r.o., Vienna, Austria on acid-free paper.

Section 1. Biology

*Aliyev Bahman Musa oglu,
Ph D., in Biology, docent,
Azerbaijan State Agrarian University,*

*Qabilov Malik Yusif oglu,
PhD., in Biology, docent,
Azerbaijan State Agrarian University,*

*Aliyeva İlaha Fizuli qızı,
PhD., in Biology, Senior lecturer,
Azerbaijan State Agrarian University,
E-mail: ilahaaliyeva@inbox.ru*

FEATURES OF THE STRUCTURE OF THE CASTANEA SATIVA MILL

Abstract: One of the most valuable tree species, which has the most diverse application. Very valuable fruit tree. In addition, it has valuable wood, is a good tanning, dyeing, nectar source plant and very decorative. Chestnut kernels are very nutritious and used for food in boiled, baked and raw form.

Keywords: *Castanea sativa*, anatomical, structure, vegetative organs.

The tree is up to 30–35 m in height and 1.5–2 m in diameter, with a wide, spreading crown. The buds are large, ovate in dark brown color. Leaves are 10–25 cm long, narrowed to the base, glabrous from above, densely pubescent from below. The petiole is 1.5–2.5 cm long. Staminate flowers are yellowish, fragrant, pistil flowers 1–3, in glomeruli. Fruit is a nut. Propagates by nuts and gives a great shoot of stump and root offspring. The best results are given by autumn crops. For spring sowing it is necessary to store the seeds in winter on dry areas. Trees of sprouts origin bear fruit from the age of 12–16, in planting on the 25–40th year; full fruiting comes from age 50. In the harvest years, one adult chestnut tree gives 50–65 kg of chestnuts. From one hectare of chestnut trees an average of one ton of nuts is collected [1].

Rapidly growing and very durable breed, reaching the age of more than 1000 years. In the forest, chestnuts older than 200 years of age are rare. Develops a power-

ful core root system. Heat-loving breed, strongly suffers from frostbite [4].

The main constituent of chestnut nuts is carbohydrates, to a lesser extent proteins and fats. In immature chestnut nuts, a high content of vitamin C (1500 mg% in fresh fruits) and a significant amount of vitamin B are found. Chestnut leaves contain the highest amount of vitamin K (600–800 biological units) among plants. Tannins are found in wood, bark, leaves and nuts. From the bark, as well as from the leaves of young branches, black and brown colors are obtained. Fruit oil, bark extract and leaves are used in medicine. The wood is sound, light brown, when stored, becomes reddish brown, light, hard, very strong, used in construction [3].

High decorative qualities of the tree are due to the powerful growth, beautiful bark, huge spreading bark, beautiful large foliage. In green construction is suitable for creating avenues, deserves a wide breeding in the gardens.

Anatomical analysis of vegetative organs of the *Castanea sativa* Mill

The *leaf* has a dorsoventral structure. The adaxial side of a sheet is strictly different from the abaxial. The leaf on both sides is covered with a single-layered epidermis. In the transverse section, the epidermal cells are small, the cell walls are thin. Over the epidermis is located the

cuticle layer. The leaf is hypostomatic, stomata are small, sparse, randomly oriented. On the upper epidermis stomata are not observed. Under the epidermis, the cells of the palisade parenchyma are located in one row. Inside the spongy parenchyma is observed [2]. There is a strong development of the central vein, over which there is a protrusion.

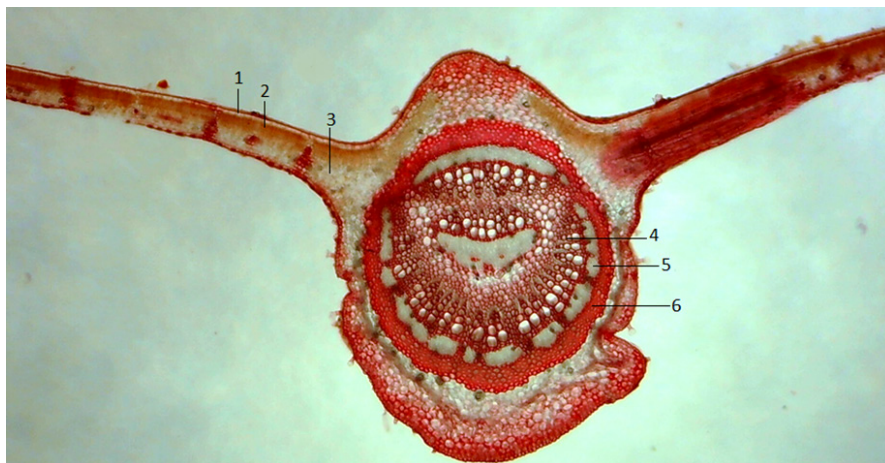

Figure 1 Anatomical structure of the leaf of the *Castanea sativa* – 1 – epidermis, 2 – palisade parenchyma, 3 – spongy parenchyma, 4 – xylem, 5 – phloem, 6 – mechanical fibers

The *petiole* of the leaf is covered with a single-row epidermis with papillae. Under the epidermis are located in 3–4 rows of the cage of the angular collenchyma. The mass of the stalk structure is the main parenchyma. The main weight of the petiole is oc-

cupied by the conducting tissue. Conductive bundles are of various sizes: large and small, bicollateral. The bundles surround the 6–7-row of sclerenchyma. Orientation of xylem and phloem is centripetal, xylem rays are numerous.

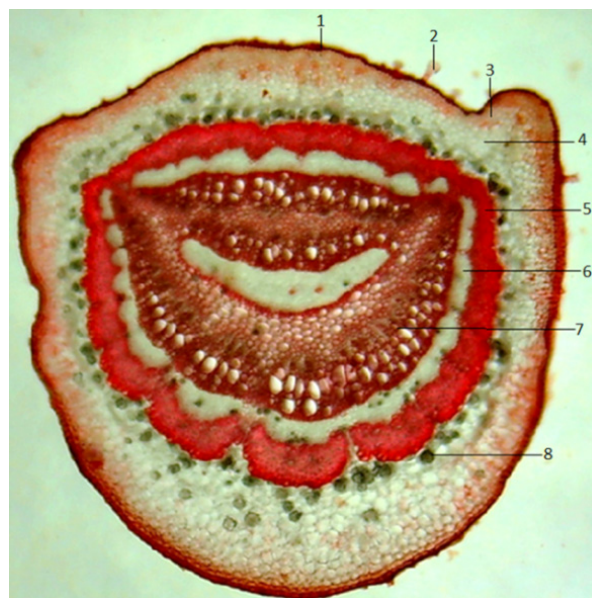

Figure 2 Anatomical structure of the petiole of the *Castanea sativa* – 1 – epidermis, 2 – trichome, 3 – angular collenchyma, 4 – parenchyma, 5 – sclerenchyma, 6 – phloem, 7 – xylem, 8 – reserve nutrients

A young **shoot** with a 4–5-row periderm. Under the periderm in 3–4 rows is located chlorenchyme, rich in chloroplasts. Chlorenchyme cells participate in the synthesis of organic substances. The main parenchyma occupies 45–50% of the mass of the shoot. The xylem is exten-

sive, occupies 1/3 of the diameter of the central cylinder, the vessels are small and large. Xylem is surrounded by phloem. Over phloem, sclerenchyma formed a circle of 4–5 rows of cells. The pith consists of large isodiometric cells. Such a structure is peculiar to a young shoot.



Figure 3. Anatomical structure of the shoot of the *Castanea sativa* – 1 – cork, 2 – cortical parenchyma, 3 – mechanical fibers, 4 – xylem, 5 – core, 6 – cambium, 7 – phloem

The primary structure of the root is tetrahic. Outside, the root is covered with periderm with numerous

root hairs [5]. Primary cortex is extensive, its cells are large, filled with starch.

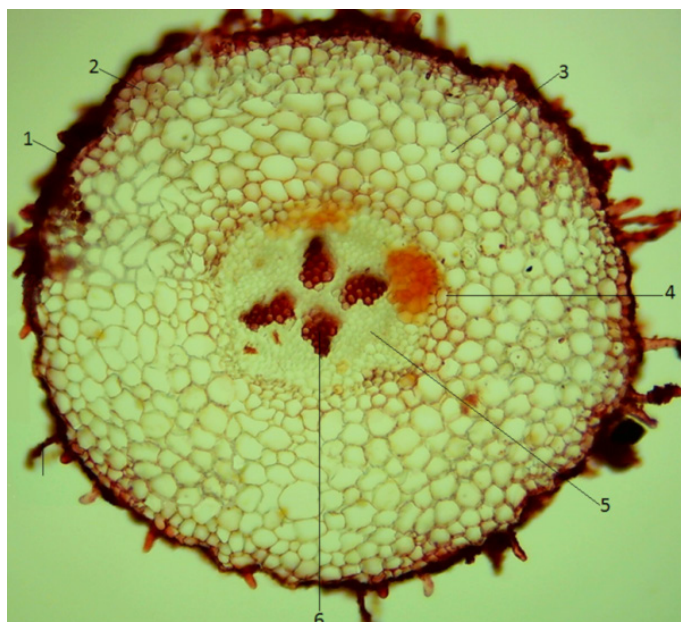

Figure 4. Anatomical structure of the root of the *Castanea sativa* – 1 – epilblem, 2 – exoderm, 3 – mesoderm, 4 – endoderm, 5 – phloem, 6 – xylem, 7 – root hairs

Conclusions

Thus, the structure of vegetative organs reflects their function and the formation environment. Histological structures reflect the intensity of the growth, organogen-

esis and death processes underlying the selection of life forms.

Anatomical signs can be used in the characterization and classification of life forms.

References:

1. Flora of Azerbaijan. – Baku. – 1961.
2. Gumbatov Z. I. Morphology and anatomy of plants. – 2017. – 692 p.
3. Gurbanov E. A. Systematics of higher plants. – 2009. – 420 p.
4. Mammadov T. S., İskender E., Talibov T. Rare trees and bushes of Azerbaijan. – 2014. – 380 p.
5. Tutayuk V. Kh. Anatomy and morphology of plants. – 1980. – 316 p.

*Alimjanova Kholishxon Alimjanovna,
doctor, of biological sciences, professor,
Chief specialist of the institute of Botany
of the Academy of Sciences of the Republic of Uzbekistan
E-mail: alimjanovakh@gmail.com*

*Soatov Giyasiddin Turdiyevich,
Specialist of the Botanical Garden of the Academy
of Sciences of the Republic of Uzbekistan*

COMPARATIVE STUDY ON DISTRIBUTION OF BACILLARIOPHYTA, CYANOPHYTA, CHLOROPHYTA AND EUGLENOPHYTA ALONG THE STREAM OF KASHKADARYA RIVER (UZBEKISTAN)

Abstract: During 2009–2017 years 150 algological samples were collected along the stream of Kashkadarya River, which are preserved in the Collection of algae and soil of Uzbekistan” of the Institute of Botany of the Academy of Science of Uzbekistan. Because of the conducted researches 54 indicator saprobic species of *Bacillariophyta* were found, 10 – *Cyanophyta*, 9 – *Chlorophyta*, and 1 – *Euglenophyta*. All divisions in total have 75 species and varieties (68 species, 6 variations, 1 form). Comparative study has been conducted on their distribution along the upper, middle and lower river stream in 8 monitoring points. It has been established that the number and variety of indicator saprobic species of all divisions decrease which is connected with the influence of anthropogenic factors.

It has been also proved that along the river stream on monitoring stations xeno and *oligosaprobic* indicators decrease (8, 11, 7, 14, 6, 6, 5, 4), and beta- and alfa-*mesosaprobic* species are more in number (12, 11, 6, 12, 9, 12, 9, 6). These data shows that increased number of beta- and alfa-*mesosaprobic* indicators in comparisons with xeno- and *oligosaprobic* indicators forecasts gradual increase in the degree of organic pollution and deterioration of water quality along the Stream of Kashkadarya River.

Keywords: Kashkadarya river, stream, monitoring points, distribution *Bacillariophyta*, *Cyanophyta*, *Euglenophyta*, *Chlorophyta*, saprobic indicator algae, *xenosaprobic algae*, *oligosaprobic algae*, *beta-mesosaprobic algae*, *alfa-mesosaprobic algae*, *polysaprobic algae*, comparison, forecasting of water pollution along the river stream, preservation of biodiversity.

Urgency of the study. Within the recent years study and preservation of species diversity in general were the main tasks of nature protection for many countries, what is proved with the Convention on Biological Diversity in Rio de Janeiro (1992) and Johannesburg (2002). The same issues were discussed during the 155th UN assembly, which took place in 1998 in Tashkent.

Study of the biological diversity of the continental water basins is one of the urgent directions of the up-to-date scientific studies. One of the continental water basins of Uzbekistan is Kashkadarya River [12, 57–466].

Algae is an integral element of biological diversity of the ecosystem of the water basins. Studying of algae species composition and their distribution along the stream course of Kashkadarya river is the urgent subject, as formation and functioning of hydrobiocoenosis of the river depends on algae groups. Moreover, the saprobic indicator algae are very important for determination and estimate of the ecological state of the water basin.

Quality control and protection of Kashkadarya’s water is one of the acute problems for today. For the first time ever, in order to resolve this problem, the scientists studied the distribution of ecological saprobic indicator

species of bacillariophyta, cyanophyta, euglenophyta, chlorophyte of Kashkadarya river in the monitoring points within 2009–2017 and they made the comparative analysis, summarized the results of all algal groups and provided the conclusions.

About exploration maturity of saprobic indicator algae of Kashkadarya river. The literature sources contain the data on the exploration maturity of the saprobic indicator algae of some water basins of Uzbekistan and other republics of Central Asia [13. 47–50; 1. 3–264; 2. 3–126; 3. 23–25; 10. 73–75; 14. 72–75]. But, there are no any data about algae, and especially saprobic indicators of Kashkadarya River per the period preceding the period of our study.

Purposes and objectives of the research.

Objective of the study is the comparative study of the species composition of ecological saprobic indicator species of bacillariophyta, cyanophyta, euglenophyta, chlorophyte of Kashkadarya River.

The tasks of the study include:

- Determination of the monitoring points on the river and collection of algological materials;
- Determination of the species composition of ecological saprobic indicator species of bacillariophyta, cyanophyta, euglenophyta, chlorophyte and their **comparative analysis**;
- Identification of trends of distribution of saprobic indicator algae along the stream of the river.

Brief physical-geographic characteristics of Kashkadarya River. According to Schultz V.L. [12, 57–466], Kashkadarya river is located in Kashkadarya valley in the aride zone between the westernmost tips of Zarafshan and Gissar ranges. According to the hydrographic features, it relates to the basin of Amu Darya river, but currently it does not reaches this river and is analyzed as an individual hydrographic body. The length of the river is 310 km. The watershed area is 8780 km². The riverhead is in the mountain area, but, when river reaches the wide valley, it adopts from the left the tributaries of Jinnidarya, Aksu, Tankhas, Kyzylidarya, Langar, Katta and Kichik Uradarya (Karasu), Yakkabag, Guzardarya, most of which are full flowing. Along the whole stream course of the river, its water is withdrawn intensively for irrigation. Below the mouth of Guzardarya, there is Karshinsk oasis with branched network of channels. The bed of Kashkadarya River is curly. The banks are abrupt,

in some places are bluffy, with the height 1–3m. Below the oasis, there is a moderate curly riverbed, which has the name Maimanakdarya, and which little by little disappears in Kashkadarya steppe. During the especially high water years, river's waters penetrate to the desert regions to Karaulbazar village and even to the border of Bukhara oasis. After having escaped from the mountain, the river divides into several branches and runs in the deep flood plain, which has the width up to 300–400 m with abrupt banks, the height of which decreases in downstream direction, as a rule (in the mountain area from 3447 to 1797 m, in the submontane area from 700–500 m and in the plain area from 500 to 200 m (Schultz, 1965) [12, 57–466].

Objects, materials and methods of the study.

Objects. The studied objects include ecological saprobic indicator algae of Kashkadarya River.

Study methods: For this study, we used algological and hydrobiological methods (Identifier of the limnetic algae of USSR [4.10–44; 5.3–619; 6.3–56; 6.3–64; 6.3–460; 6.3–20; 6.3–55; 6.3–67]. Identifier of the limnetic algae of Ukrainian SSR [7. 3–50] Identifier of proto-coccus algae of Central Asia, 1979; [8. 3–300; 8. 3–85] Identifier of cyanophyta of Central Asia, 1987, 1988; [9. 502–600; 9. 905–1016] Unified methods of water quality control, 1977) [11, 70–170]).

In order to explore distribution of ecological saprobic indicator algae along the Stream of Kashkadarya River, we determined the monitoring points (MP), constant and periodic. The stations were selected in the inhabited localities, which are crossed with Kashkadarya River and its tributaries running from the mountain area, submontane and plain areas of Kashkadarya valley and oasis.

Constant MP: Ist station – the beginning of the head part of Kashkadarya river (Bashir tributary), Hazrati Bashir village; II^d – Kitab city, the northern part, (Hairabad); III^d – Chirakchi city, Raionabad, till the water reservoir Chimkurgan; IVth – Chim village, after the water reservoir Chimkurgan and the district center Kamashi; Vth – Akrabot village; VIth – Karshi village (bridge); VIIth – Kasan city (Karabair village); VIIIth – Mubarak city. Periodic MP: IXth – Aksu river (Kitab city), Xth – Tanhaz river (Miraki village, Shahrisabz city, the Southwestern part), XIth – Guzardarya river (Tursari village and Guzar city), XIIth – Kyzylidarya river (Yakkabag village), XIIIth – Chim channel, XIVth – Anhor channel etc.

Materials. Within the exploration period, we have collected and analyzed more than 150 algological samples, which are stored in the algological collection “Collection of algae-vegetation of water basins and soils of Uzbekistan”. We have formed the flora classified files and the classified geographical and ecological lists of algae of Kashkadarya river, which are included to the databases of the algological collection. Below we provide analysis of the collected materials about distribution of saprobic algae for 8 constant monitoring points of Kashkadarya River and their comparative analysis (table 1).

Study results. The study and analysis of availability of the ecological saprobic indicator algae of Kashkadarya river basin revealed 75 species and varieties of saprobic indicators, which relate to 4 algae groups. According to the number of species, the leading among them is *Bacillariophyta*, which has 54 species and varieties or 72% from total content of saprobic indicators. It is followed by *Cyanophyta* (10 species or 13.33%), *Chlorophyta* (10 species or 13.33%), *Euglenophyta* (1 species or 1.34%) (table.). Below we provide the consequences of the distribution of the saprobic indicators along the stream of the river by algae groups.

I. The results of the study of Bacillariophyta distribution along the Stream of Kashkadarya River

The study revealed 54 species of the saprobic indicator algae in the bacillariophyta group (Table 1), 7 species of which are the **xenosaprobic** species: *Xenosaprobe* – *Melosira arenaria* Moore, *Fragilaria virescens* Ralfs are frequent in the IVth MP in the midstream of the river; *Diatoma hiemale* (Lyngb.) Heib. Are frequent

in the Ist, II^d and IVth MP in the upper and midstream of the river; *xeno-beta-mesosaprob* *Achnanthes lanceolata* (Breb.) Grun. Are frequent in the II^d MP; *Caloneis alpestris* (Grun.) Cl. Are frequent in the II^d and Vth MP; *xeno-oligosaprobe* *Cymbella ventricosa* Kuetz. Is rear in the Ist, II^d are very few in the IVth MP in the upper and midstream of the river (Table1).

Oligosaprobes include in total 18 species, among them: *the oligosaprobe Cyclotella bodanica* Eulenst are rear in the VIth MP in the midstream, *C.comensis* Grun. Are rear in the VIIth MP in the downstream; *C.comta* (Ehr.) Kuetz. Are rear in the IVth, VIth MP in the midstream and the VIIIth MP in the downstream of the river (Table 1). *Fragilaria bicapitata* A. Meyer is rare in the IVth MP in the midstream; *Gomphonema intricatum* Kuetz.– are frequent in the IVth, *G.intricatum var. pumilum* Grun. Are rear in the Ith and III^d MP; *Rhopalodia gibba* (Ehr.) O. Muell. are rear in the III^d MP in the midstream of the river. *Oligo-xeno-saprobe* – *Diatoma anceps* (Ehr.) Kuetz. Is very frequent in the IVth MP in the midstream; *Oligo-beta-mesosaprobe-Melosira diskiei* (Thw.) Kuetz. Is rear in the VIIIth MP in the downstream and *M. italica* (Ehr.) Kuetz.– is frequent in the IVth MMP in the midstream of the river.

Cymbella affinis Kuetz. Is very few in the II^d, III^d and is rear in the IVth MP in the upper and midstream, and *Nitzschia dissipata* (Kuetz.) Grun. Is frequent in the VIIIth MP in the downstream of the river.

Synedra ulna (Nitzsch.) Ehr. is frequent in the Ist, III^d, Vth MP, **v** is widely increasing in the II^d, IVth MP, and from the VIth to VIIIth MP, their increase becomes weaker, they become less frequent.

Table 1.– Distribution of *Bacillariophyta* ecological saprobic indicator algae along the Stream of Kashkadarya River and frequency of their occurrence

№	The classified list of the algae – saprobic indicators	Distribution of saprobic indicator algae along the stream of the river								Algae saprobity, S
		upper		mid			down			
		Monitoring points (MPs)								
	Algae group	I	II	III	IV	V	VI	VII	VIII	
	<i>Bacillariophyta</i>	H. Bashir v.	Kitab c.	Chirakchi c.	Chim v.	Akrabot c.	Karshi c.	Kasan c.	Mubarak c.	
1	2	3	4	5	6	7	8	9	10	11
1.	<i>Melosira arenaria</i> Moore				x ч					x
2.	<i>M. diskiei</i> (Thw.) Kuetz.								oβp	oβ
3.	<i>M. italica</i> (Ehr.) Kuetz.				oβч					oβ
4.	<i>M. varians</i> Ag.	β оч	β ч	β ч	βч	β p				β

1	2	3	4	5	6	7	8	9	10	11
5.	<i>Cyclotella bodanica</i> Eulenz.						o p			o
6.	<i>C. comensis</i> Grun.							o p		o
7.	<i>C. comta</i> (Ehr.) Kuetz.				o p		o p		o p	o
8.	<i>C. meneghiniana</i> Kuetz.								aβp	aβ
9.	<i>Stephanodiscus dubius</i> (Fricke) Hust.					β p				β
10.	<i>Tabellaria fenestrata</i> (Lyngb.) Kuetz.						oβp			oβ
11.	<i>T. fenestrata var. intermedia</i> Grun.							oβч		oβ
12.	<i>Diatoma anceps</i> (Ehr.) Kuetz.				ox oч					ox
13.	<i>D. elongatum</i> (Lyngb.) Ag.		βo p							βo
14.	<i>D. hiemale</i> (Lyngb.) Heib.	x ч	x ч		x ч					x
15.	<i>D. vulgare</i> Bory		oβ p		oβ ч		oβp			oβ
16.	<i>Fragilaria bicapitata</i> A. Meyer				o p					o
17.	<i>F. capucina</i> Desm.	oβ ч	oβ ч	oβp	oβ p	oβp				oβ
18.	<i>F. virescens</i> Ralfs				x p					x
19.	<i>Synedra berolinensis</i> Lemm.				β ч		β p	β p		β
20.	<i>S. pulchella</i> (Ralfs) Kuetz.				βam					βα
21.	<i>S. tabulata</i> (Ag.) Kuetz.				α ч					α
22.	<i>S. ulna</i> (Nitzsch) Ehr.	o ч	o м	o ч	o м	o ч	o p	o p	o p	o
23.	<i>S. ulna var. biceps</i> (Kuetz.) Schonf.	β p								β
24.	<i>Cocconeis pediculus</i> Ehr.						β ч			β
25.	<i>Achnanthes lanceolata</i> (Breb.) Grun.		xβ ч							xβ
26.	<i>Rhoicosphenia curvata</i> (Kuetz.) Grun.				β ч				β p	β
27.	<i>Diploneis ovalis var. oblongella</i> (Naeg.) Cl.								β p	β
28.	<i>Navicula atomus</i> (Naeg.) Grun.	β p							β ч	β
29.	<i>Caloneis alpestris</i> (Grun.) Cl.		x p			x p				x
30.	<i>C. amphisbaena</i> (Bory) Cl.						βap			βα
31.	<i>Gyrosigma acuminatum</i> (Kuetz.) Rabenh.	β p				βpч	β p	β p		β
32.	<i>G. spenceri</i> (W. Sm.) Cl.	β ч		β p						β
33.	<i>Cymbella affinis</i> Kuetz.		oβ e	oβe	oβ p					oβ
34.	<i>C. helvetica</i> Kuetz.	xo p			xo ч	xop				xo
35.	<i>C. lanceolata</i> (Ehr.) V.H.				β p	β p				β
36.	<i>C. naviculiformis</i> Auersw.				β p					β
37.	<i>C. prostrata</i> (Berkeley) Cl.				β e			β p		β
38.	<i>C. ventricosa</i> Kuetz.	xo p	xo p		xo e					xo
39.	<i>Gomphonema constrictum</i> Ehr.	β p	β p	β p	β p	β p				β
40.	<i>G. intricatum</i> Kuetz.				o ч					o
41.	<i>G. intricatum var. pumilum</i> Grun.	o p		o p						o
42.	<i>G. lanceolatum var. insigne</i> (Greg.) Cl.		α e							α
43.	<i>G. olivaceum</i> (Lyngb.) Kuetz.					β p	β p			β
44.	<i>Rhopalodia gibba</i> (Ehr.) O. Muell.			o p						o

1	2	3	4	5	6	7	8	9	10	11
45.	<i>Bacillaria paradoxa</i> Gmelin						β e			β
46.	<i>Nitzschia acicularis</i> W. Sm.						α ч	α ч		α
47.	<i>N.dissipata</i> (Kuetz.) Grun.							оβч		оβ
48.	<i>N.linearis</i> W. Sm.		оβ p	оβe					оβ p	оβ
49.	<i>N.longissima</i> (Breb.) Ralfs						β p	β p		β
50.	<i>N.longissima f. parva</i> V. H.							β ч		β
51.	<i>N.sigmoidea</i> (Ehr.) W. Sm.		β p		β p	β p	β ч	β p	β p	β
52.	<i>Cymatopleura solea</i> (Breb.)W.Sm.	βα p								βα
53.	<i>Surirella angustata</i> Kuetz.	βα p								β
54.	<i>S.robusta var. splendida</i> Ehr.						β p			β
	Number of algae in total and their distribution in MPs:	14	14	9	24	11	15	11	9	54
	Total number of algae along the stream (upper, mid, down):	22			40			19		

Notice: the value of saprobity is indicated in bold here and in other tables.

Saprobity: **x** – xeno-saprobe, **o** – oligo-saprobe, **β** – beta-mezosaprobe, **α** – alfa-mezosaprobe; **p** – polysaprobe. Frequency of algae occurrence: *e* – very few, *p* – rare, *ч* – frequent, *оч* – very frequent, *м* – in great volume

In Kashkadarya River there are 25 species of **beta-mezosaprobies** including beta-mezosaprobe – *Melosira varians* Ag., which is frequent in the Ist MP, frequent in the II^d, III^d, IVth MP, rare in the Vth MP in the upper and midstream. *Stephanodiscus dubius* (Fricke) Hust. is rare in the Vth MP in the midstream. *Synedra berolinensis* Lemm. is rare in the IVth, rare in the VIth, VIIth MP in mid and lower stream of the river, as well *S.ulna var. biceps* (Kuetz.) Schonf. is rare in the Ist MP in upper stream. *Cocconeis pediculus* Ehr. is frequent in the VIth MP, *Rhoicosphenia curvata* (Kuetz.) Grun. – is frequent in the IVth, rare in the VIIIth MP in the upper and downstream of the river. *Gyrosigma acuminatum* (Kuetz.) Rabenh. is rare in the Ist MP in the upper stream and is frequent in the Vth, VIth, VIIth MP in the mid and lower stream of the river. *G. spenceri* (W. Sm.) Cl. is frequent in the Ist, rare in the III^d MP in the upper and midstream of the river. *Cymbella lanceolata* (Ehr.) V.H. is rare in the IVth and Vth MP, *C.naviculiformis* Auersw. is rare in the IVth, *C. prostrata* (Berkeley) Cl. – is very few in the IVth and rare in the VIIth MP in the mid and downstream of the river. *Gomphonema constrictum* Ehr. is rare in the I–Vth MP in the upper- and midstream, a *G.olivaceum* (Lingb.) Kuetz. is rare in the Vth, VIth MP in the midstream of the river. *Bacillaria paradoxa* Gmelin is very few in the VIth MP in the midstream of the river. *Nitzschia sigmoidea* (Ehr.) W. Sm. is spread along the whole stream of the river: rare in the II^d, IVth, Vth, VIIth, VIIIth and frequent in the VIth MP.

Beta-mezo-oligosaprobe *Diatoma elongatum* (Lyngb.) Ag. is rare in the II^d MP. *Beta-alfa-mezosaprobe* *Caloneis amphibaena* (Bory) Cl. is rare in the VIth MP in the midstream, *Cymatopleura solea* (Breb.) W. Sm. and *Surirella angustata* Kuetz. is rare in the Ist MP in the upper stream of the river.

In Kashkadarya River there are 4 species of **alfa-mezosaprobies** including *Synedra tabulata* (Ag.) Kuetz., which is frequent in the IVth MP in the midstream, *Gomphonema lanceolatum var. insigne* (Greg.) Cl. is very few in the II^d MP in the upper stream, *Nitzschia acicularis* W. Sm. – is frequent in the VIth, VIIth MP in the mid- and downstream of the river. *Alfa-beta-mezosaprobe* *Cyclotella meneghiniana* Kuetz. is rare in the VIIIth MP in the lower stream of the river (Table 1).

Polysaprobies were not found along the Stream of Kashkadarya River.

Analysis of distribution of the ecological saprobic indicator bacillariophyta revealed that their amount fluctuates and decreases: in MPs – **14, 14, 9, 24, 11, 15, 11, 9** and along the stream – **22, 40, 19** (Table 1). It is resulted with impact of ecological abiotic, biotic and anthropogenic factors of the environment.

The results prove that the group of saprobic indicator bacillariophyta includes 7 species and 12.97% of *Xeno-saprobe*; 18 species and 33.33% of *oligosaprobe*, 25 species and 46.30% of *beta-mezosaprobies* and 4 species and 7.4% of *alfa-mezosaprobies*. No *polysaprobies* were found.

The amount of contaminated water indicators – *beta-* and *alfa-mesosaprobies* exceeds the amount of pure water indicators *xeno-* and *oligosaprobe*. Their ratio is 29: 25 species and 53,70: 46,30% (Table 2).

Moreover, the (Table 2) indicates the **regularity** in distribution of the ecological saprobic indicator bacillariophyta:

- Downstream the amount of xeno and oligosaprobic indicator bacillariophyta reduces and even tends to zero, in comparison to them, the amount of beta- and alfa-mesosaprobic indicator species increases.

In view of this, we can predict quality of water:

- Increase of total species of beta- and alfa-mesosaprobic indicator bacillariophyta proves moderate contamination of water downstream of Kashkadarya River.

II. The results of the study of *Cyanophyta* distribution along the Stream of Kashkadarya River

The study revealed 10 species of the saprobic indicator algae in the cyanophyta group including 1 **xeno-saprobic** species *Oscillatoria nigra* Vauch. (x), which is rare in the II^d monitoring point (MP) in the upper stream of the river. Four species of saprobic indicator algae among ten are *beta-mesosaprobic* algae. These four *β-mesosaprobies* are rare *Lyngbya limnetica* Lemm. in the

Ist monitoring point in the tributary Hazrati Bashir, as well *Merismopedia elegans* A. Br. is rare in the II^d MP (Kitab c.) in the upper stream and *M. punctata* Meyen in the VIth MP (Karshi c.) in the midstream of the river. *Merismopedia tenuissima* Lemm. is *beta-alfa mesosaprobic* species, which is rare in the II^d MP (Kitab c.) in the upper stream and in the VIIth MP (Kasan c.) in the downstream of the river (Table 2).

Four saprobic indicator algae among ten are *alfa-mesosaprobic* indicator algae. Among all *alfa-mesosaprobies*, *Oscillatoria brevis* (Kuetz.) Gom. is rare in the Ist MP (Hazrati Bashir v.) in the upper stream and in the Vth MP (Akrabat v.) in the midstream of the river; *Oscillatoria princeps* Vaucher is rare in the Ist MP (Hazrati Bashir v.); *O. tenuis* Ag. is frequent in the II^d MP (Kitab c.) in the upper stream of the river; *Phormidium foveolarum* (Mont.) Gom. is rare in the IVth MP (Chim v.) in the midstream of the river.

Such polysaprobies as *Oscillatoria chlorina* (Kuetz.) Gom. are rare in the Ist MP (Hazarti Bashir v.) in the upper stream of the river.

Oligosaprobic indicator species of cyanophyta tend to zero along the Stream of Kashkadarya River.

Table 2. – Distribution of ecological saprobic indicator *Cyanophyta* along the Stream of Kashkadarya River and frequency of their occurrence

No.	Classified list of algae – saprobic indicators	Distribution of saprobic indicator algae along the stream of the river								Algae saprobity, S
		upper		mid			down			
		Monitoring points (MP)								
		I	II	III	IV	V	VI	VII	VIII	
H. Bashir v.	Kitab c.	Chirak-chi c.	Chim v.	Akrabat v.	Karshi c.	Kasan c.	Mubarak c.			
1	2	3	4	5	6	7	8	9	10	11
I	<i>Cyanophyta</i>									
1.	<i>Merismopedia elegans</i> A. Br.		β p							β
2.	<i>M. punctata</i> Meyen						β p			β
3.	<i>M. tenuissima</i> Lemm.		βα p					βα p		βα
4.	<i>Oscillatoria brevis</i> (Kuetz.) Gom.	α p				α p				α
5.	<i>O. chlorina</i> (Kuetz.) Gom.	p p								p
6.	<i>O. nigra</i> Vauch.		x p							x
7.	<i>O. princeps</i> Vaucher	α p								α
8.	<i>O. tenuis</i> Ag.		α ч							α
9.	<i>Phormidium foveolarum</i> (Mont.) Gom.				α p					α

1	2	3	4	5	6	7	8	9	10	11
10.	<i>Lyngbya limnetica</i> Lemm.	β p								β
	Totally in MPs:	4	4	0	1	1	1	1	0	10
	Totally along the stream:	8		3			1		10	

Analysis of distribution of the ecological saprobic indicator cyanophyta revealed that their amount decreases: in MPs – **4, 4, 0, 1, 1, 1, 1, 0** and along the stream – **8, 3, 1** (Table 2). It is resulted with impact of ecological abiotic, biotic and anthropogenic factors of the environment.

The results prove that the group of saprobic indicator cyanophyta includes almost none of *oligosaprobe*; 1 species of *Xenosaprobe*, *polysaprob*; 4 species of *beta-mesosaprob* and *alfa-mesosaprob*, which amount almost 80% of total amount of saprobic indicators (Table 2).

Conclusions: Increase of number of *beta-* and *alfa-mesosaprobic* indicator cyanophyta species proves moderate contamination along the Stream of Kashkadarya River.

III. The results of the study of *Euglenophyta* and *Chlorophyta* distribution along the Stream of Kashkadarya River

The study of saprobic indicators revealed that the group of *Euglenophyta* include rarely 1 species of *beta-mezo-saprob*, (β) *Strombomonas fluviatilis* (Lemm.) Defl. in the III^d monitoring points (MP) in the mid-stream of the river.

We revealed that the group of *chlorophyta* includes 10 saprobic indicator algae. Seven species among them are **beta-mesosaprobic** algae. These seven β -*mezoprob* rarely include *Scenedesmus opoliensis* Richter in the VIIIth MP in the downstream, *S. quadricauda* (Turp.) Breb. in the VIth MP in the midstream of the river (Table 6).

We revealed the large-scale growth of *Cladophora fracta* Kuetz. in the Ist MP in the upper stream, *Cl. glomerata* (L.) Kuetz. in the Ist MP in the upper stream and VIIth MP in the downstream of the river. As well we revealed the large-scale growth of β -*mezoprob* *Spirogyra majuscula* (Kuetz.) Czurda in the III^d MP in the midstream. *Cosmarium formosulum* Hoff. is rare in the II^d MP in the upper stream of the river.

Two saprobic algae species among 10 are *oligosaprobic* algae: *Mougeotia genuflexa* (Dillw.) Agardh., is frequent in the Ist MP in the upper stream of the river; *Spirogyra fluviatilis* Hilse is frequent in the Vth MP in the downstream and is spread in large volume in the Ist MP in the upper stream. Intensive growth is noticed in the II^d, III^d, IVth, VIth, VIIth MP along the whole stream of the river.

Table 3. – Distribution of saprobic indicator *Euglenophyta* and *Chlorophyta* along the Stream of Kashkadarya River and frequency of their occurrence

No.	Algae groups and their species composition	Distribution of ecological saprobic indicator algae along the stream								Algae saprobity, S
		Stream of the river								
		upper		mid			down			
		Monitoring points (MP)								
		I	II	III	IV	V	VI	VII	VIII	
		H. Bashir v.	Kitab c.	Chirakchi c.	Chim v.	Akrabot v.	Karshi c.	Kasan c.	Mubarak c.	
1	2	3	4	5	6	7	8	9	10	11
III	<i>Euglenophyta</i>									
1	<i>Strombomonas fluviatilis</i> (Lemm.) Defl.			β p						β
	Totally in MPs:			1						1
	Totally along the stream:	0		1			0		1	
IV	<i>Chlorophyta</i>									
1	<i>Scenedesmus opoliensis</i> Richter								β p	β
2	<i>S. quadricauda</i> (Turp.) Breb.						β p			β

1	2	3	4	5	6	7	8	9	10	11
3	<i>Ulothrix zonata</i> Kuetz.					o ч				o
4	<i>Stigeoclonium tenue</i> Kuetz.		а ч			а p				а
5	<i>Cladophora fracta</i> Kuetz.	β M								β
6	<i>Cl. glomerata</i> (L.) Kuetz.		β M					β M		β
7	<i>Mougeotia genuflexa</i> (Dillw.) Agardh.	o ч								o
8	<i>Spirogyra fluviatilis</i> Hilse	o ч M	o M	o M	o M	o ч	o M	o M		o
9	<i>S. majuscula</i> (Kuetz.) Czurda			β M						β
10	<i>Cosmarium formosulum</i> Hoff.		β p							β
	Totally in MPs:	3	4	3	1	3	2	2	1	10
	Totally along the stream:	6		6			3			10

We revealed that **alfa-mesosaprobic** (**α**) group includes such indicator algae species as *Stigeoclonium tenue* Kuetz., which is frequent in the II^d MP in the upper stream, rare in the Vth MP in the midstream of Kashkadarya river.

Analysis of saprobic indicator *euglenophyta* and *chlorophyta* proves, that the species composition decreases in the monitoring points: **3, 4, 3, 1, 3, 2, 2, 1** and along the stream: **6, 6, 3**. It is resulted with contamination of water and improvement of mineralization and other inhibitive chemical agents, which have negative effect on survival of some algae.

Obtained data proves that the values of *xenosaprobic* indicator algae tend to zero. Less numerous are *oligosaprobe*, there are 3 types of them. *Beta-mesosaprobic* are numerous and they include 7 types. *Alfa-mesosaprobic*

include only one type (Table 7). There is none of polysaprobic. Availability of *beta-* and *alfa-mesosaprobic* indicator *chlorophyta* proves moderate contamination along the Stream of Kashkadarya River.

Discussion of the study results

According to the above mentioned comparative analysis of saprobiological data, it is obvious that almost equal results, which prove that the species composition of saprobic indicators changes, their amount fluctuates and decreases along the stream of Kashkadarya river (Tables 1, 2, 3; pic. 1, 2, 3), were obtained in all algae groups (*Bacillariophyta*, *Cyanophyta*, *Chlorophyta* u *Euglenophyta*). Total number of species in all algae groups demonstrates the same facts, that species composition fluctuates and decreases along the stream of the river by the following way: **21, 22, 13, 26, 15, 18, 14, 10** (Table 4; pic 4, 5).

Table 4.– Distribution of ecological saprobic indicator algae in the monitoring points of Kashkadarya River and their amount

Algae groups	Saprobity scale and their conventional value	Total saprobic indicators and their percentage, %		Monitoring points and amount of saprobic indicators							
				I	II	III	IV	V	VI	VII	VIII
				H. Bashir v.	Kitab c.	Chirakchi c.	Chim v.	Akrabot v.	Karshi c.	Kasan c.	Mubarak c.
1	2	3	4	5	6	7	8	9	10	11	12
Bacillariophyta	<i>Xenosaprobe</i> , x	7	12.97	3	4	–	5	2	–	–	–
	<i>Oligosaprobe</i> , o	18	33.33	3	5	6	8	2	5	4	4
	<i>Beta-mesosaprobic</i> , β	25	46.30	8	4	3	9	7	9	6	4
	<i>Alfa-mesosaprobic</i> , α	4	7.4	–	1	–	1	–	1	1	1
	<i>Polysaprobic</i> , p	0	0.0	–	–	c	–	–	–	–	–
	Totally in MPs:	54	100	14	14	9	23	11	15	11	9
Cyanophyta	<i>Xenosaprobe</i> , x	1	10	–	1	–	–	–	–	–	–
	<i>Oligosaprobe</i> , o	0	0	–	–	–	–	–	–	–	–

1	2	3	4	5	6	7	8	9	10	11	12
Cyanophyta	<i>Beta-mezosaprobies, β</i>	4	40	1	2	–	–	1	1	1	–
	<i>Alfa-mezosaprobies, α</i>	4	40	2	1	–	1	–	–	–	–
	<i>Polysaprobies, p</i>	1	10	1	–	–	–	–	–	–	–
	Totally in MPs:	10	100	4	4	–	1	1	1	1	–
Chlorophyta	<i>Xenosaprobe, x</i>	0	0	–	–	–	–	–	–	–	–
	<i>Oligosaprobe, o</i>	3	30	2	1	1	1	2	1	1	–
	<i>Beta-mezosaprobies, β</i>	6	60	1	2	2	–	–	1	1	1
	<i>Alfa-mezosaprobies, α</i>	1	10	–	1	–	–	1	–	–	–
	<i>Polysaprobies, p</i>	0	0	–	–	–	–	–	–	–	–
	Totally in MPs:	10	100	3	4	3	1	3	2	2	1
Euglenophyta	<i>Beta-mezosaprobies, β</i>	1	100	–	–	1	–	–	–	–	–
	Totally in MPs:	1	100	–	–	1	–	–	–	–	–
Totally:	<i>Xenosaprobe, x</i>	8	10.67	3	5	–	5	2	–	–	–
	<i>Oligosaprobe, o</i>	21	28.00	5	6	7	9	4	6	5	4
	<i>Beta-mezosaprobies, β</i>	36	48.00	10	8	6	10	8	11	8	5
	<i>Alfa-mezosaprobies, α</i>	9	12.00	2	3	–	2	1	1	1	1
	<i>Polysaprobies, p</i>	1	1.33	1	–	–	–	–	–	–	–
	Totally in MPs:	75	100	21	22	13	26	15	18	14	10

Decrease of the species composition along the Stream of Kashkadarya River indicates that there are the substantive causes, which impact number of species composition of saprobic indicator algae. It can be the limiting factors – one of ecological factors of water environment.

Using the consolidated results (Table 4), it is possible to calculate a range of species of *xeno* – and *oligosaprobic* indicators – indicators of pure water – they include 29 species and 38.67%. Beta- and *alfa-mezo-saprobic* indicators – indicators of moderately contaminated water – they include 45 species and 60%. Limited amount (1 species and 1.33%) of *polysaprobies* are the indicators of contami-

nated water. These facts prove that general quality of water in the river is close to moderately contaminated.

Along the stream of the river in the monitoring points (MP), there are few species of *xeno* – and *oligosaprobic* indicators – 8, 11, 7, 14, 6, 6, 5, 4, and more *beta*-, *alfa-mezo-saprobic* indicators – 12, 11, 6, 12, 9, 12, 9, 6 (Pic. 6). Also, due to these facts we can estimate, that increasing amount of *beta*- and *alfa-mezo-saprobic* indicators, in comparison with amount of *xeno*- and *oligosaprobic* indicators, predicts step-by-step increase of water contamination and deterioration of water quality along the Stream of Kashkadarya River.

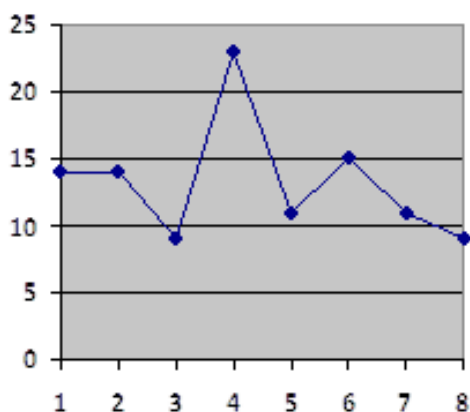

Picture 1. Fluctuation of saprobic Bacillariophyta amount

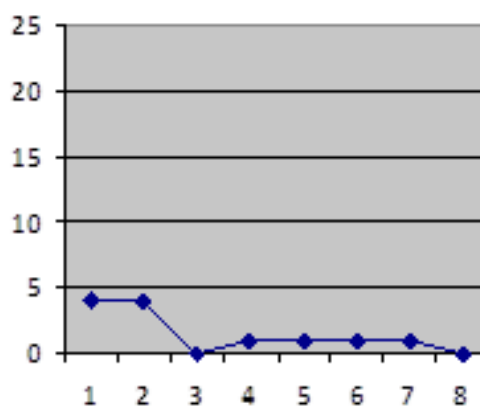

Picture 2. Fluctuation of saprobic Cyanophyta amount

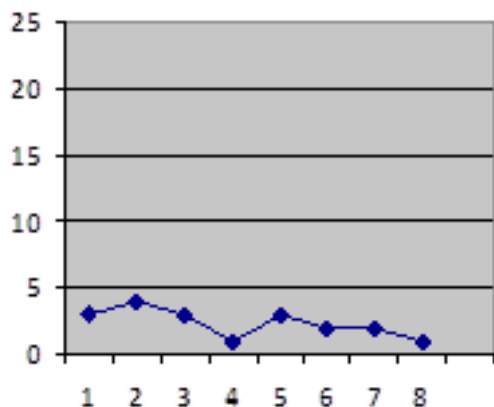

Picture 3. Fluctuation of saprobic Chlorophyta amount

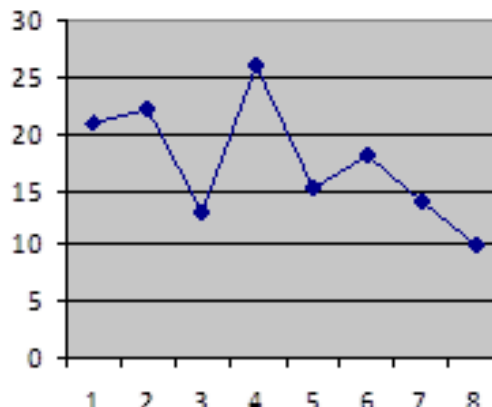

Picture 4. Fluctuation of total saprobes amount

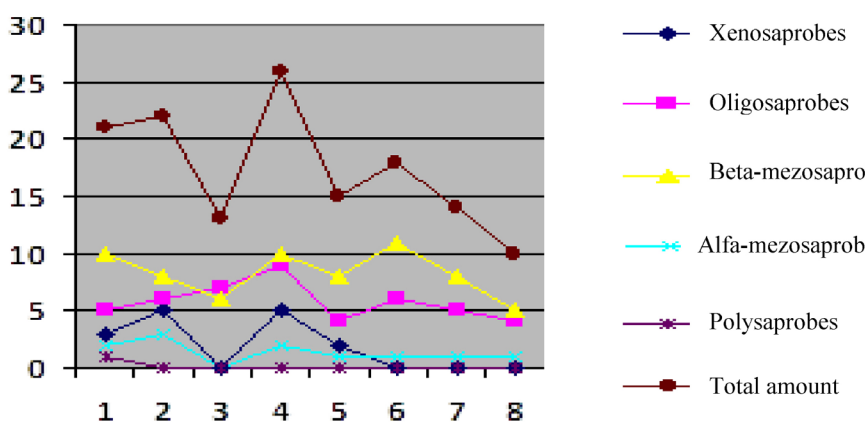

Picture 5. Changes in total amount of saprobic algae along the stream (MP) of Kashkadarya River

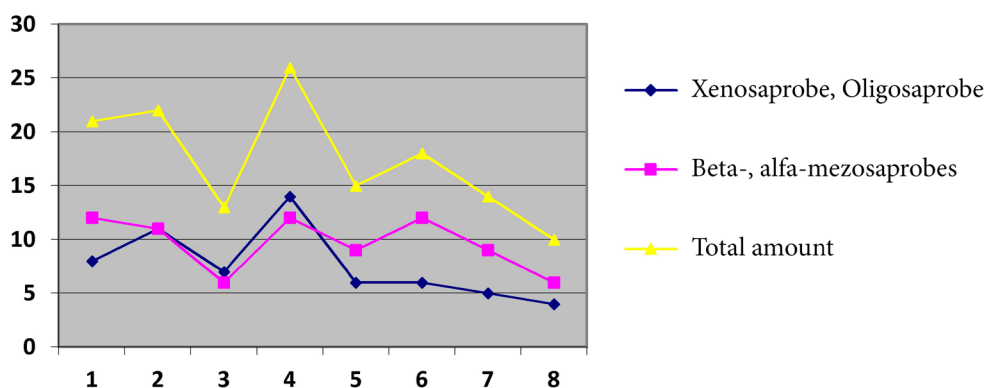

Picture 6. Changes in total amount in comparison of xeno-, oligosaprobic with beta-, alfa-mesosaprobic indicator algae along the stream (MP) of Kashkadarya River

Conclusions

Therefore, due to the study of ecological saprobic indicator algae distribution along the Stream of Kashkadarya River, we have been able to:

- determine for the first time ever availability of *saprobic* indicators (there are 75 species and varieties of them);

- compare distribution of Bacillariophyta, Cyanophyta, Chlorophyta, Euglenophyta (are spread along the stream almost equally);
- make specific their total amount distributed along the stream (their amount decreases in 8 monitoring points: **21, 22, 13, 26, 15, 18, 14, 10**);

- identify differences among xeno-, oligosaprobic and beta-, alfa-mezo-saprobic indicators by comparing amount of species distributed along the stream (8, 11, 7, 14, 6, 6, 5, 4: 12, 11, 6, 12, 9, 12, 9, 6);
- predict based on dominants *beta-, alfa-mezo-saprobic* indicators gradual deterioration of moderate contamination and quality of water along the stream of Kashkadarya river.
- Thereby, it is necessary to develop the measures to preserve biodiversity of ecological saprobic indicator algae of the river.

References:

1. Алимжанова Х. А. Закономерности распределения водорослей бассейна реки Чирчик и их значение в определении эколого-санитарного состояния водоемов. – Ташкент: Фан, – 2007. – 265 с.
2. Алимжанова Х. А., Шайимкулова М. А. Альгофлора реки Акбууры и ее значение в оценке качества воды. – Ташкент: Фан, – 2008. – 126 с.
3. Алимжанова Х. А., Эшмуродова Н. Ш. Экологический анализ альгофлоры реки Ахангаран // Баркамол авлод тарбияси ва экологик мувозанат муаммолари: Рес. илмий-амалий семинар материаллари. – Самарқанд, – 2010. – Б. 23–25.
4. Жузе А. П., Киселев И. А., Порецкий В. С., Прошкина-Лавренко А. И., Шещукова В. С. Диатомовый анализ. Кн. 2. – Л.: Госгеолгиздат, – 1949. – 44 с.
5. Забелина М. М., Киселев И. А., Прошкина – Лавренко А. И., Шещукова В. А. Определитель пресноводных водорослей СССР. Вып. 4. Диатомовые водоросли. – М.: Советская наука, – 1951. – 619 с.
6. Определитель пресноводных водорослей СССР. – Вып. 1, 2, 4, 7, 10(1), 11(2). – М.: Советская наука, – 1951, 3–56; 1953, 3–64; 1951, 3–460; 1955, 3–20; 1982, 3–55; 1986, 3–67.
7. Определитель пресноводных водорослей Украинской ССР. Вып. 6. Улотриксые и кладофоровые водоросли. Киев: Наукова думка, – 1979. – 500 с.
8. Определитель протококковых водорослей Средней Азии. кн. I, II. – Ташкент: Фан, – 1979. – 343 с.; – 383 с.
9. Определитель синезеленых водорослей Средней Азии. – Ташкент: Фан, – 1987, – 1988. – 1216 с.
10. Тошпўлатов Й. Ш. Зарафшон дарёси ўрта оқими индикатор-сапроб сувўтларининг тарқалиши ва уларнинг сув сифатини баҳолашдаги аҳамияти // ЎзР ФА Маърузалари. – 2012. – № 4. – Б. 73–75.
11. Унифицированные методы исследования качества вод. Ч. III. Методы биологического анализа вод. 1-е изд. доп. и перераб / Отв. за выпуск Губачек З. – М.: СЭВ, – 1977. – 185 с.; Приложение 1. Индикаторы сапробности. – 92 с.; Приложение 2. Атлас сапробных организмов. – 107 с.
12. Шульц В. Л. Реки Средней Азии. – Л.: Гидромет, – 1965. – С. 57–466.
13. Эргшев А. Э. Сапробные водоросли, обнаруженные в водоемах Средней Азии, и их значение в биологической очистке // Эколого-физиологическое изучение водорослей и грибов Средней Азии. – Ташкент: Фан, – 1978. – С. 47–50.
14. Юлдашева М., Олимжонова Х. Индикатор-сапроб сувўтларининг Шохимардонсой-Марғилонсой дарё оқимлари бўйлаб тарқалиши // ЎзР ФА Маърузалари. – 2013. – № 3. – Б. 72–75.

*Ergasheva Olimaxon Xaliqjonovna,
National University of Uzbekistan
E-mail: e-olima@mail.ru*

*Gafurova Lazizakhon Akramovna,
National University of Uzbekistan
E-mail: glazizakhon@yandex.ru*

*Djalilova Gulnora Tulkunovna,
National University of Uzbekistan
E-mail: gulnora_jalilova@rambler.ru.*

DISTINCTIVE FEATURES OF THE DISTRIBUTION OF MEDIUM HIGH MOUNTAIN SOILS AND THEIR DEGREE OF ERODIBILITY

Abstract: Distinctive features of the distribution of mountain cinnamonic soils and subtypes are described in the paper, the distinction in morphological indices, chemical, agrochemical and physical properties of these soils are given, as well as the content and character of humus distribution, CO₂ carbonates in the composition of absorbed bases, depending on their location in various slope exposition and their susceptibility to erosion. It is established that all these indices are closely related to climate, slope exposition, the composition of soil-forming rocks and the state of plant cover.

Keywords: Mountain cinnamonic soils, subtypes of cinnamonic carbonate, cinnamonic typical, cinnamonic leached, soil erosion, degree of erodibility, morphological indices, thickness of the humus horizons, humus, chemical, physical properties, clay-forming, relief, steepness and exposition of slopes, soil protection.

Introduction: The problem of studying mountain soils and their protection from erosion is becoming more and more urgent. This is due, firstly, to the recognition of the outstanding role of soil in the life of biosphere, and secondly, to the recognition of the fact that the top-soil is now in unfavorable ecological state. Indeed, by now it has been convincingly shown that soil is not only the main means of agricultural production, but also an important component of earth biogeocenosis, a powerful energy accumulator on the earth, a regulator of the composition of atmosphere and hydrosphere, a reliable barrier to the migration of pollutants. However, it is necessary to state that this earth component of biosphere undergoes considerable degradation. Of all its aspects, the most widespread and harmful is soil erosion. Therefore, it is no accident that the authorities in Uzbekistan pay serious attention to the problems of soil protection from erosion.

Current state of the issue: Mountain soils have been studied by many researchers (I.P. Gherasimov, 1948, M.A. Glazovskaya, 1956; A. Z. Ghenusov, B. V. Gorbunov, N. V. Kimberg, 1961; B. V. Gorbunov, N. V. Kimberg, 1975; A. Z. Ghenusov, 1983; O. M. Mamytov, 1986; M. A. Mazirov, 1995; A. S. Nazarov, 1996; M. F. Fakhrudinova, 1998; Kh. M. Makh sudov, L. A. Gafurova, I. Turapov, A. Khanazarov, 2002; G. M. Nabieva, 2008; L. A. Gafurova, 2017; G. T. Djalilova, 2017 and others).

However, there is still no consensus on the nature of mountain soil formation; the distinctions in the genesis of mountain soils have not been adequately established, their classification and methodology for large-scale soil-erosion mapping, which should account for the features of erodibility of mountain soils located in different expositions and elements of the slope, have not been developed.

With this in mind, we set the task of studying the ecological-genetic state of the main top-soil, the certain features of medium high mountain soils and their degree of erodibility in mountain areas, while simultaneously compiling a soil erosion map for the development and deployment of erosion control measures, including biogeocenosis protection.

Materials and methods of research: The subjects of research are mountain cinnamonic typical soils common in mountainous regions. The investigations were carried out by three methods: 1) route-expeditionary one with cutting of soil sections (slits) along the slope elements; 2) camera-laboratory one; 3) stationary-field. Soil profiles were laid on the slopes of southern expositions, as the most prone to erosion, and also at northern expositions.

Results of research and their discussion: As a result of long-term field route-expeditionary and laboratory research in the area under study, the following subtypes of mountain cinnamonic soils have been identified:

Mountain cinnamonic calcareous (eroded) soils; the criterion for subtyping is the thickness of the carbonate-leached layer of the profile. This is reflected by the high laying of soil, i.e. a difference in general climatic character, and particular features – the effect of exposition and moisture content. The most pronounced clay-forming of the entire stratum, especially the middle part, is characteristic for cinnamonic soils. The feature of cinnamonic mountain soils is a carbonate content of the mineral part carbonates. The degree of carbonation and the depth of occurrence of carbonates depend on the stage of soil development. In carbonate calcareous soils, they occur from the surface, in typical and leached soils the occurrences are determined by the depth and intensity of soil saturation by atmospheric precipitation. A different ratio of soils and soil formations makes it possible to distinguish a combination with a predominance of fine-earth-skeletal differences, as well as outcrops and screes. Soil-forming rocks of cinnamonic calcareous soils are mainly loess-like loams and eluvium of limestones. On steep slopes of the juniper belt, these soils often develop on slates and limestones deluvium, less often on deluvial loess-like loamy soils. Cinnamonic careous soils located on southern slopes usually suffer heavily from grazing, they are heavily eroded, fine-grained, skeletal-fine-grained soils on proluvium and eluvium of bedrock. Geological process of formation of erosion relief has contributed to the rise of known differences in the properties of virgin cinnamonic calcareous soils along the elements of the slope. Sharp changes occur in the content of humus, nitrogen and other nutrients. The noted differences, although related to some surface distribution of substances and moisture content under the influence of geological erosion, are mostly the results of

unregulated grazing of livestock. Due to pasture erosion, the soil is washed away.

Mountain cinnamonic typical soils on the investigated objects are distributed above cinnamonic careous soils, at an altitude from 1200 to 1800 m above sea level. They are developed under large-grass-shrubby vegetation, shrub thickets, juniper forests. Cinnamonic typical soils has the humus horizon more powerful than cinnamonic calcareous soils, more pronounced illuvial layer and more deep-lying calcareous layer (100–200 cm). The process of clay-forming in cinnamonic typical soils is more developed than in cinnamonic calcareous soils.

The study of the main morphological properties of mountain-cinnamonic typical soils has shown the following features: deep humus profile, i.e. the presence of a rather thick dark-colored humus horizon A; humus content in this horizon varies considerably, and therefore one can distinguish a light (low-humus), dark (medium-humus) and humus types of cinnamonic soils. In the color of the transition horizon (B₁, and even more so B₂), brown and dark brown tones are more pronounced. Downward along the profile, the color gradually becomes lighter from light brown to whitish, due to a decrease in humus content and the appearance of carbonates; deep processing of the whole humus horizon by earthworms and digging animals; compacted clay-forming horizon in the middle part of the profile and fracturing.

The presence of carbonate illuvial horizon at a certain depth: in carbonate cinnamonic soils – within the humus horizon A, in typical soils – in the lower part of the profile, at depth of 110–180 cm, a massive accumulation of carbonates, the boundary of carbonates being sharp. The mountain-cinnamonic leached soils are developed on the most humid areas of the range of mountain cinnamonic soils. They are distributed above cinnamonic typical soils or are combined with them. The composition of vegetation there are: meadow-steppe cenosis with iris, teresken, etc., as for the shrubs – archa, spruce, apple, walnut.

Cinnamonic leached soils are distributed in the upper stripe of cinnamonic soil belt, below they turn into cinnamonic typical soils, which gradually give way to cinnamonic careous soils. Mountain cinnamonic leached soils differ in the thickness of the humus horizon, formation of various subtypes of cinnamonic soils.

Morphological description of the sections reveals the following features of mountain cinnamonic leached soils: a

thick humus horizon, brown color, well-pronounced granular-pulverescent and lumpy-granular structure, absence of a pronounced carbonate horizon. Leaching from carbonates is characteristic for the upper and middle parts of the profile. Individual carbonate discharges appear below.

Thus, the study of morphological indices of cinnamonic soils has shown that the structure of the top-soil is closely related to the relief, slope exposition, composition of soil-forming rocks and the state of vegetation, this has caused the formation of various subtypes of cinnamonic soils.

Chemical and agrochemical indicators of cinnamonic soils, distinctions in morphology and physical properties of these soils, in particular in the content and distribution of humus, carbonates, in the composition of absorbed bases and other components, are noted. The distribution and content of humus in the vertical profile of soils under consideration are specific. Cinnamonic typical soils are characterized by a moderate content of humus in the upper horizon and a sharp decrease in it below the sub-turf horizon. The humus content in the upper turf and sub-turf horizons varies from 5.8 to 7.3% or less, downward its amount decreases considerably. In the upper horizon of mountain cinnamonic calcareous soils, the humus content varies from 1.11 to 3.15% depending on the slope exposition and the degree of erodibility; downward decrease in humus content being gradual. In cinnamonic calcareous soils, an amount of humus is less than in cinnamonic typical soils, which is due to the sparse plant cover, on the one hand, and the rapid rate of mineralization of the organic mass under conditions of eluvial-xeromorphic regime, on the other hand. Mountain cinnamonic soils are characterized by a wide carbon-nitrogen ratio: in the upper humus horizon it is from 7 to 11.8, in the subsequent ones – from 5.1 to 8.9. The enrichment of humus with nitrogen depends to a large extent on its qualitative composition. In the upper horizons (to a depth of 60–100 cm), the carbonate content does not exceed 1% of the soil mass. In the rock this index reaches 8–9%, and the boundary between the transition and carbonate horizons is sharply expressed. In the carbonate horizon, in addition to the pseudomycelium carbonates, the white-eye and concretions are observed.

Cinnamonic calcareous soils have a high content of carbonates throughout the profile. If in typical cinnamonic soils the carbonate content does not exceed 1% in the upper one meter layer, then in cinnamonic calcareous soils it

varies from 6 to 16% along the profile. Thus, the obtained materials on the content of humus and nutrients show that the formation of the humus horizon, its thickness and humus content is largely determined by the exposition of the slope, soil erodibility, and the supply of organic matter. With the increase in slope steepness, the humus content and thickness of the humus horizon decrease, especially in cinnamonic calcareous soils on the southern slopes.

The structure of the top-soil of the area under study is closely connected with the climate, slope exposition, slope element, the composition of soil-forming rocks and the state of vegetation; all that causes the formation of mountain cinnamonic calcareous soils, mountain – cinnamonic typical, as well as mountain – cinnamonic leached ones, which differ in morphological features, mechanical composition, chemistry and susceptibility to water erosion.

Conclusions: Erosion processes are intensively developing due to the complex geological and geomorphologic structure of soil surface with significant slopes and depth of local bases of erosion, weak erosion-preventive stability of soils and soil-forming rocks, non-uniform distribution of atmospheric precipitation, stormy rains in spring, large-scale plowing of land, lack of erosion-preventive measures.

The top-soil structure is closely related to the climate, slope exposition, the composition of soil-forming rocks and the state of vegetation. These factors cause the formation of cinnamonic soils of the vertical belt. The accumulation of salty fractions was found everywhere, especially in the middle part of the profile. Significant skeletal nature of soil was also noted, especially on the slopes of southern exposition.

It was revealed that the formation of the humus horizon, its thickness and humus content is largely determined by the exposition of slope, soil erodibility, chemical and physical properties, and reserve of plant mass. With an increase in slope steepness, the humus content and thickness of the humus horizon decrease.

Erosion processes have largely changed the morphogenetic, chemical, agrochemical and agrophysical properties of soils. With increasing degree of erodibility, the content and reserves of humus, the reserves of nutrients, the amount of physical clay decreased; the structure deteriorated, and the number of waterproof aggregates and moisture content in soil decreased.

References:

1. Gafurova L. A., Djalilova G. T. Modern Approach to the Study of Erosion-hazardous lands in the Sukoksai Basin using GIS Technology. – Tashkent: “Fan va tekhnologiya”. – 2017. – 144 p.
2. Gherasimov I. P. On the Types of Soils of Mountainous Countries and Vertical Soil Zoning. J.: Soil Science, – No. 11. – 1948. – P. 56–78.
3. Ghenusov A. Z., Gorbunov B. V., Kimberg N. V. Soil-climatic Zoning of Uzbekistan for Agricultural Purposes. Tashkent, – 1960. – P. 118–120.
4. Ghenusov A. Z. Soils and Land Resources of Central Asia. Tashkent. Publishing house “Fan” UzSSR. – 1983. – 136 p.
5. Glazovskaya M. A. Soils of Bostandyk District, Nature and Economic Conditions of the Mountainous Part of Bostandyk // Alma-Ata, Academy of Sciences of Kazakhstan, – 1956.
6. Gorbunov B. V., Kimberg N. V. Cinnamonic Soils of Medium-high Mountains of Uzbekistan. In “Soils of Uzbekistan”. – Tashkent: Fan, – 1975.
7. Djalilova G. T., Zabiroy F. M., Ananova K. K. Soil-geo-botanical Survey of Mountainous Territories for the Development of Effective Methods of Erosion Control of Soils. Multidisciplinary scientific edition, International Academy journal Web of Scholar 8 (№ 17, November), Warsaw, Poland, – 2017. – P. 11–14.
8. Mamytov A. M. Soils of Central Asia and Southern Kazakhstan Mountains. Frunze. Ilim Publishing House, – 1982. – 250 p.
9. Mazirov M. A. – Thermo-physical Properties of the Basic Soils of the Western Tien Shan. Thesis of Doc. Degree, Moscow State University, – Moscow, – 1995. – P. 5–7.
10. Makhsudov Kh. M., Gafurova L. A., Turapov I., Khanazarov A. Mountain and Foothill Soils of Uzbekistan. Their Genetic Features and Protection. Proc. of the III Congress of Soil Scientists and Agrochemists, Uzbekistan, – 2002. – P. 44–55.
11. Nabieva G. M. Soils of the Western Spurs of the Chatkal range and their enzymatic activity. Thesis of Candidate Degree, – Tashkent, – 2008. – P. 7–17.
12. Nazarov A. S. Soils of the Western Spurs of the Chatkal Range. Thesis of Candidate Degree, Tashkent, – 1996. – P. 5–9.
13. Fakhruddinova M. F. Soils of the Northern Part of the Turkestan Range. Thesis of Candidate Degree, – Tashkent, – 1998. – P. 5–9.

*Dusimbetov Bakhodir Olimbaevich,
Karakalpak branch of the Uzbekistan Academy of Sciences.
Deputy of the Institute of natural sciences
E-mail: svetmamb@mail.ru*

ANALYSIS OF INTRASPECIFIC STRUCTURE OF ASSOCIATIONS OF SHALLOW MAMMALS OF SOUTHERN ARAL SEA AREA

Abstract: The analysis of intraspecific structure of associations of shallow mammals of Priaralie is conducted in the article. Set, that span-new ecological terms to that plastic kinds can adapt ecologically are created in anthropogenic landscapes. For most types of rodents in anthropogenic landscapes forage terms of biotopes of limitation.

Keywords: Priaralie, ecosystem transformations, intraspecific structure, adapt ecologically, rodents.

Cooperation and comparative analysis of animal population of different natural zones in ecological and evolutionary aspects is one of interesting open questions of modern ecology. At the study of populations surface vertebral, shallow mammals are one their the most often used objects in ecological researches [1, 3]. Shallow mammals, due to a high quantity, specific variety and ecological changeability, show clear reactions on natural and anthropogenic changes, therefore fully reasonably to use them for determination and estimation of changes aleak in natural associations in natural way [2]. The exposure of specific composition and quantity of mammals in different biotopes allows to get to know basic conformities to law of forming of local biotas and unseal their mechanisms of functioning. 13 types of rodents are registered in lower reaches of Amudarya.

A *Mus musculus* (13.6%), *Nesokia indica* (23.2%), *Allactaga elater* (14.5%), *Meriones tamariscinus* (15.3%), is especially numerous. 17 kinds are marked in the gipseous desert, from them *Allactaulus acontion* (15.5%) is numerous, *Allactaga elater* (13.5%), *Citellus fulvus* (9.2%), *Rhombomys opimus* and *Meriones erythrourus* (19.5%).

Other kinds register oneself extremely irregularly, in single copies, and can be attributed to the categories rare and casual. There is prevailing of *Citellus fulvus* (74.6%) and *Rhombomys opimus* (20.5%). The "Regional effect" due to penetration of foreign kinds in lower reaches of Amudarya river is expressed extraordinarily poorly, therefore associations of rodents of the remote and close areas located to anthropogenic territories steppe and deserted arrays are not had reliable distinctions [7, 8, 9]. Because of growth of desertization, degradation of tugai and reed

jungles, sharply territory of distribution and quantity of mezophilus kinds grow short intensification of land-tenure and other negative factors. The xserophilus types of rodents of substantial influence of anthropogenic press do not test, vice versa, growth of aridization and desertization, forming of the sandy-salt-marsh desert on the drying day of sea, result in expansion of territory of their distribution and growth of quantity [5]. 18 types of rodents are registered in deserted biocenosis, including: basic base-line kinds *Rhombomys opimus* (18.5%) and *Meriones meridianus* (9.8%), *Spermophilopsis leptodactylus* (20.2%) and псаммофильные kinds, such as jerboas (45.8%).

Tugai biogeocenosis under influence of general process of transformation of landscape suffered huge succession alterations. Intensive transformation of ecosystems of Aral sea area, under act of the anthropogenic pressing, mastering of tugai under irrigable agriculture assisted reduction and break of natural natural habitat of all rodents of tugai complex [6, 7, 8]. For examined period of time in the associations of tugai ecosystems on a background cyclic vibrations there were the clearly expressed trends of increase of total abundance of rodents (picture).

In a greater degree it is characteristic for tugai ecosystems and related to character of dynamics of base-line kinds. On the whole the height of quantity of rodents well comports with general motion of dynamics of average annual temperature and clean products in all ecosystems of South Southern Aral sea area.

As a result of mastering and irrigation of tugai, deserted and semideserted ecosystems of Southern AralSea area, a quantity and harmfulness of most types of rodents are taken to the minimum. In the last the meaningful changes

of structure happened 10–15, variety and abundance of associations of shallow mammals in the different ecosystems

of Southern Aral sea area, that resulted in the increase of zonal contrast of population of shallow mammals.

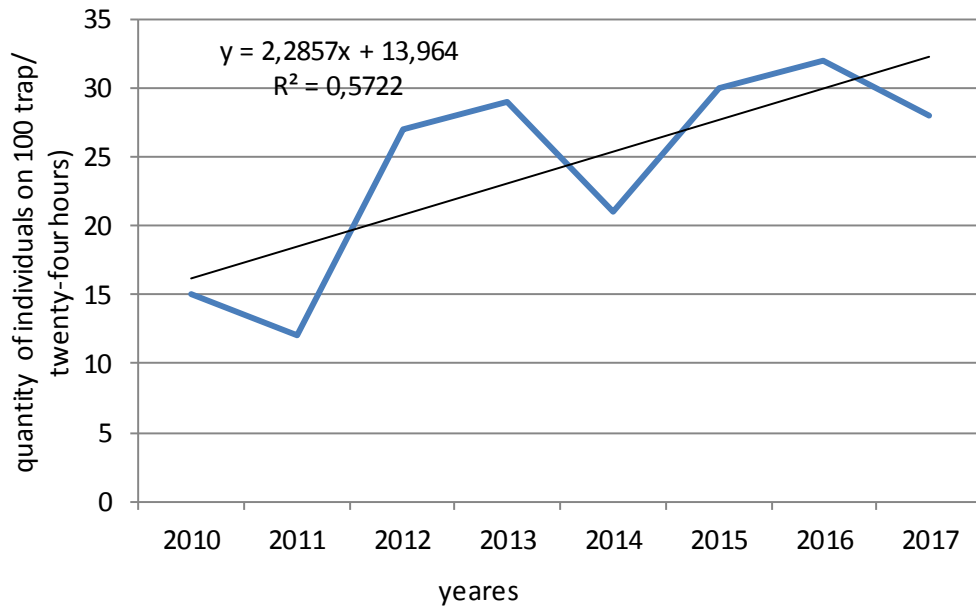

Picture. A dynamics of total quantity of associations of shallow mammals is in tugai ecosystems (R^2 – is a size of authenticity of approximation)

Substantial structural changes were suffered by the populations of *Spermophilopsis leptodactylus* and *Ellobius talpinus*. Being the strictly specialized kinds, they were not able to adapt oneself to landscape of anthropogenic origin, and their natural populations, from narrowing of area of characteristic biotopes to low-limit, appeared on verge of disappearance [4, 9]. The natural habitats *Allactaga elater* and *Meriones meridianus* in a spatial relation are divided into the separately isolated micropopulation.

In an agricultural landscape these kinds now and then form local settlements in intrazonal biotopes alternating with the deserted arrays. The base-line types of the unmastered deserts are *Meriones tamariscinus* and *Meriones erythrourus*. These kinds form certain closeness on the peripheral areas of agricultural landscape due to the mosaics of biotopes.

Association of rodents of irrigable zone genetically heterogeneous and counts a few kinds: *Mus musculus*, *Nesokia indica*, *Meriones erythrourus* and *Meriones tamariscinus*. Depending on the reaction of separate types of rodents on an anthropogenic press and adaptations to the agricultural landscape they can be divided into two groups. To the first group the immigrants of tugai-streamside complex behave: *Mus musculus*, *Nesokia*

indica. These kinds, forming a steady and numerous enough population in an irrigable zone, found adequate with primary cenosis ecological terms depending on influence of climatic terms. In the second group the kinds-immigrants of the deserted complex are included: *Meriones erythrourus* and *Meriones tamariscinus*. They do not call deep into agricultural landscape and found more or less favourable terms in his peripheral spaces, capacity of their populations in an agricultural landscape insignificant.

From the elements of anthropogenic landscape an open drainways has the most essential ecological value for rodents. These building are the basic biotopes of residence and reservation 5 types of rodents: *Mus musculus*, *Nesokia indica*, *Ondatra zibethica*. Embankments and dikes of collectors, having loose soil, are the preferred places of burrows *Nesokia indica*. Inhabited the landscape of deserted-flat zone is presented by settlements and stock-raising complexes that is occupied by 2 types of rodents: *Mus musculus*, *Nesokia indica*.

The different types of rodents have a different degree of attachment to the anthropogenic complexes [1, 3, 9]. Depending on the reaction of kinds on anthropogenic transformation of landscape, three ecological groups are clearly distinguished: kinds with a positive

reaction (*Mus musculus*, *Nesokia indica*, *Ondatra zibethica*); kinds with an indifferent reaction (*Rhombomys opimus*, *Meriones erythrourus* and *Meriones tamariscinus*); kinds with a negative reaction (*Citellus fulvus* and *Spermophilopsis leptodactylus*, *Meriones meridianus*). It is necessary to mark that the same kind in different landscape-geographical districts shows an ambiguous reaction to the anthropogenic complexes.

Thus, span-new ecological terms to that plastic kinds can adapt ecologically are created in anthropogenic landscapes. Transformation of landscape has direct and indirect influence on a fauna and population of rodents, creating the optimal terms of existence for one kinds and, vice versa, unfavorable for other. For swingeing majority of types of rodents in anthropogenic landscapes forage terms of biotopes of limitation.

References:

1. Bolshakov V.N. Ways of adaptation of shallow mammals to the mountain terms.– M.: Science,– 1972.– 199 c.
2. Ivanter E. V. Population ecology of shallow mammals of the Taiga North–west of SSSR.– L.– Science,– 1975.– 246 p.
3. Istomin A. V. Structural–functional organization of associations and populations of shallow mammals: estimation, diagnostics and prognostication of the state of ecosystems // Scientific researches in reserves and national parks of Russian Federation for – 1998–2000,– M.,– 2007.– C. 442–443.
4. Litvinov Yu. N. Influence of factors of different nature on the indexes of variety of associations of shallow mammals // Successes of modern биологии.– 2004.– Т. 124.– No. 6.– С. 612–621.
5. Karaseva E. V., Toshigin Yu. V. Rodents of Russia.– M.,– 1993.– 164 p.
6. Mambetullaeva S. M., Bakhiev A. B. State of animal and vegetable kingdom of Karakalpakstan and kinds needing urgent measures of guard // Collection of theses of III “Problems of the rational use and guard of biological resources of Southern Aral Sea area”, Nukus,– 2010.– 43 p.
7. Mambetullaeva S. M., Tureeva K. J., Bekmuratova D. M. Description of spatial structure of populations of shallow mammals in lower reaches of Amudarya // Magazine graduate “Student and competitor”,– M., Russia,– 2012.– No. 2.– С. 47–48.
8. Reymov R. R. The rodents of Southern Aral Sea area.– Nukus,– 1987.– 125 p.
9. Tikhonova G. N., Tikhonov I. A., Bogomolov P. L., Kotenkova E. V. Ecological aspects of forming of fauna of shallow mammals of urbanism territories of the Middle stripe of Russia.– M.: KMK,– 2012.– 372 p.
10. Schwarzas S. S. Ecological conformities to law of evolution.– M.: Science,– 1980.– 278 p.

Jumaev Rasul Axmatovich,
associate professor,
In the Department of Plant Protection
from Pests and Quarantine
Sabirov Sobir Karimbaevich,
Master degree, Department of Plant protection
from pests and quarantine
Juraeva Nozimaxon Boxodirxon Qizi,
Bachelor degree, Department of Plant protection
from pests and quarantine.
Bolqiboev Shoxrux Shavkat O'g'li,
Bachelor degree, Department of Plant
protection from pests and quarantine
Toshkent state agrarian university. Uzbekistan
E-mail: rasul-jumaev@mail.ru
E-mail: jumaevrasul1990@gmail.com

BIOECOLOGY OF GENERATIONS OF TRICHOGRAMMA DILUTED BY DIFFERENT METHODS

Abstract: In Uzbekistan, a great attention is paid to the use of biological method, in particular entomophags which, unlike the chemical method is characterized by safety to the environment and high biological efficiency reaches 65–70%.

Biological effectiveness of Natural generations: biological effectiveness of *T.chilonis* in 1:10 ratio in 5 days illustrates 58%, in 7 days shows 69%, 9 days presents 76%. Biological effectiveness of the reared generations in biolaboratory: biological effectiveness of *T.chilonis* in 1:10 ratio in 5 days illustrates 61%, in 7 days shows 72%, 9 days presents 81%. Biological effectiveness of in vitro generations: biological effectiveness of *T.chilonis* in 1:10 ratio in 5 days illustrates 61%, in 7 days shows 70%, 9 days presents 89%.

Keywords: bioecology, generations, biomethod, trichogramma, rearing technology, in vitro, hemolymph, entomophage migration, biological effectiveness.

Introduction: Food security is now one of the global problems of the world. Biodiversity plays an important role in promoting agricultural crops. Reproduction of entomophags in laboratories requires a lot of financial costs [1; 2; 6].

In the crop protection system of cotton, great importance is attached to the parasite-the egg-eating species-the species of the river.

In agrobiocenoses are found on cotton, corn, tomato, cabbage, beet and other crops. It is considered one of the main entomophages in the protection of crops from

harmful butterflies, tk. focusing on the smell of the pest, lays 1–2 eggs in the pest eggs in which further develops, feeding on the inner contents.

Trichogrammatidae, a detachment of Hymenoptera. Despite the small sizes of 0.12–1.2 mm, the insects belonging to this family of chalcids are considered parasites-oviphids of scoops, moths and many other harmful lepidopteran pests, develop inside their eggs. Unlike larvae, adults eat nectar flowers.

This indicates a great deal of damage to the food industry. On average, one female can lay 45–60 eggs. The

biological efficiency is 65–70%. Optimum conditions for development are: temperature within 20–330 ° C at relative humidity of 75–90%. In the population, the number of females is more and is 75–90%. In the conditions of Uzbekistan it gives 10–12 generations.

Growing eggs of scoops – natural hosts of *Trichogramma*.

To obtain the *Trichogramma* mother material, it is necessary to pass it through the autumn and winter stages through growing in a bio-laboratory in the eggs of natural hosts. [1; 3; 4; 5; 6].

For the production of pest eggs, in the conditions of a biological laboratory, the butterflies or pupae of the scoop collected in nature by various methods (for

example, light traps) are grown. One of the directions of obtaining eggs from butterflies of natural hosts is the breeding and reproduction of them in a biological laboratory on artificial or natural environments.

In the process of mass production of *Trichogramma* parasite in laboratory conditions, the production of egg eggs is a great many ingredients (barley, wheat) and labor. As a result, the cost of replication increases. Nowadays science and education are in the midst of a growing number of problems, such as the intensification of entomophag species and the further improvement of their use, automation of reproduction, and the creation of artificial feeding environments [1; 2; 5].

Table 1. – Development of *T.chilonis* in various environments (2016–2017 years)

Development of <i>T.chilonis</i> in various environments	Ratios	Development dates and biological effectiveness (%)		
		5 days	7 days	9 days
Biological effectiveness of Natural generations				
<i>T.chilonis</i>	1:10	58 ± 0.02	69 ± 0.03	76 ± 0.03
	1:15	51 ± 0.5	59 ± 0.04	67 ± 0.03
	1:20	39 ± 0.03	48 ± 0.02	51 ± 0.02
Biological effectiveness of thereared generations in biolaboratory	Ratios	5 days	7 days	9 days
<i>T.chilonis</i>	1:10	61 ± 0.03	72 ± 0.02	81 ± 0.03
	1:15	53 ± 0.02	65 ± 0.03	69 ± 0.05
	1:20	42 ± 0.05	54 ± 0.02	59 ± 0.04
Biological effectiveness of in vitro generations	Ratios	5 days	7 days	9 days
<i>T.chilonis</i>	1:10	61 ± 0.03	70 ± 0.03	89 ± 0.05
	1:15	52 ± 0.05	66 ± 0.04	73 ± 0.03
	1:20	42 ± 0.04	55 ± 0.05	61 ± 0.04

The table presents information about percentage of biological effectiveness of *T. chilonis* in various environments.

Biological effectiveness of Natural generations: biological effectiveness of *T.chilonis* in 1:10 ratio in 5 days illustrates 58%, in 7 days shows 69%, 9 days presents 76%.

Biological effectiveness of *T.chilonis* in 1:15 ratio in 5 days illustrates 51%, in 7 days shows 59%, 9 days presents 64% (Table 1).

Biological effectiveness of *T.chilonis* in 1:20 ratio in 5 days illustrates 39%, in 7 days shows 48%, 9 days presents 51%.

Biological effectiveness of the reared generations in biolaboratory: biological effectiveness of *T.chilonis* in

1:10 ratio in 5 days illustrates 61%, in 7 days shows 72%, 9 days presents 81%.

Biological effectiveness of *T.chilonis* in 1:15 ratio in 5 days illustrates 53%, in 7 days shows 65%, 9 days presents 69%.

Biological effectiveness of *T.chilonis* in 1:20 ratio in 5 days illustrates 42%, in 7 days shows 54%, 9 days presents 59%.

Biological effectiveness of in vitro generations: biological effectiveness of *T.chilonis* in 1:10 ratio in 5 days illustrates 61%, in 7 days shows 70%, 9 days presents 89%.

Biological effectiveness of *T.chilonis* in 1:15 ratio in 5 days illustrates 52%, in 7 days shows 66%, 9 days presents 73%.

Biological effectiveness of *T.chilonis* in 1:20 ratio in 5 days illustrates 42%, in 7 days shows 55%, 9 days presents 61% (Table-1) [4; 5; 6].

However, more than 140–150 thousand tons of barley are allocated for bio-laboratories in the country annually. It is best to transfer artificial environments to entomophags, determining the responsibilities of production, storage and distribution of effective species [5; 6].

Reproduction of one Trichogrammain artificial environments will solve many problems. At the same time, it provides annual storage of grain, such as barley, corn, wheat, in our country [2; 5].

Artificial cultivation of Trichogrammanhas created several components of the environment and carried out researches on it. When studying the composition of egg species of the Trichogramma, it was determined that protein, fat, non-organic salt, water existed. The composition of the calves' eggs is very similar to one of them. Therefore, hemolymph of wormwood (*G.melonnellan*) worm, which is easy to reproduce in laboratory conditions, is taken as a basis. The pumice hemolymph of the cotton tunnel (*H.armigera*) and the autumn tunnel (*A.seggetum* sift) were also used for research. For this purpose, artichokes of Trichogrammaare shaped like eggs of eggs of the tango.

Trichogrammaspp: *T. evenecens*, *T.pintoe*, *T.chilonis*. These two types of heart rate were brought to the laboratory in the Eggplant (*H.armigera*) on the cotton fields of the Buka district of Tashkent region and eggs in the autumn tunnel (*A.seggetum* cure).

Artificial Nutritional Ingredients: Seven-year-old worm or calf hemolimphane is a pollen (*G.melonnellan*) or horsetail (*Heliothis armigera*), chicken breast, cow's milk or dry milk solution, Neisenheimerneorganic salt bottling. Preparation of artificial food composition.

Removal of Hemolymph from Insect: Before taking the hemlimus of night worms or spores 5 to 6 minutes, water is taken from them for 5 to 6 minutes and then extracted from the water and separated from them by means of a small cut of liquid and put into a special stirred container.

Chicken egg yolk: Chicken egg is first cleaned with 75% alcohol and placed underneath the ultrafolet flask for 20 minutes, then breaking the egg and separating egg yolk from the bottles.

Milk: 10% dry milk solution or 10% dry milk solution (dissolved in 10 ml of distilled water) is boiled for 10–11 minutes.

Neorganic salt broth: Neisenheimerneorganic salt (NaCl 7.5 g, KCl 0.1 g, CaCl_2 0.2 g, Na HCO_3 0.2 g, H_2O 100 mL) is prepared from formyl.

The whole process should be carried out in a completely clean and fitted room. Required Laboratory Equipment and Equipment: Special Thermostat, Tuberculosis 50-PX, Polyethylene Material 0.2–0.4, MM, 96% Alcohol, Ultrasonic Lamp, Petrol Plate, Tube, Centrifuges 2500, Medical Syringe 2, 5 ml, 5 ml, and all equipment must be distilled [1; 2; 3].

The prepared feed medium was poured into 96% ethyl alcohol in a purse-shaped "egg card", and the next 0.4 mm polyethylene was mixed. Fertilized seeds were fertilized by a 1: 1 ratio of the fertilized and fed Trichogramma (*Trichogrammapintoi*, *Trichogrammaevenecens*, *Trichogrammachilonis*), which was harvested the previous day before entering the test pack (50-PX) [4; 5; 6].

Research results

Trichogramma have two types of Trixogramma: *Trichogramma pinto*, *Trichogrammaevenecens*, these species are resistant to extrinsic conditions. Toxicity damage to the media is carried out on the basis of favorable conditions for the development of each species and placed in a thermostat under these conditions. *T.pinto* was exposed to ozone culture at $+25 \pm 5^\circ \text{S}$ at $70 \pm 5\%$ relative air humidity. In order to compare the Trichogrammageneration in all nutrient environments with the tunable seeds in the natural environment, the controllable varieties of cotton tunnel eggs were also infected with Trichogramma.

The above options were arranged in 20 bottlenecks and an effective nutritional medium was isolated.

Summary. The first colonization with the Trichogramma takes place 5–6 days after the detection of 2–3 butterflies of a cotton scoop per day by pheromone traps. The second and third time in 3–4 days after the detection of 1.2 butterflies per day. It is necessary to pay attention to the uniform distribution of the biomaterial. To do this, the Trichogrammaprepared for the exit from infected eggs is laid out in 2 or 3 l cans, then 100 pieces are laid out there. folded 1–1.5 cm of scraps of paper on which the evolved individuals of the entomophage are resettled. During the study, it was clear that all the

nutrient environments were infected with *Trichogramma*.) He put his eggs on him. However, some nutrient environments have been reported to be incurable because of the inconvenience for parasite generation. In the nutritional environment, thrombotic parasites con-

tinued to develop relatively more than in the nutritional medium, due to the high proportion of hemolymph in the wax. The reason for this is that hemoglobin contains more protein and fat, and is suitable for the development of parasitic larvae [4; 5; 6].

References:

1. Li Li-ying, Liu Wen-hui. Rearing *Trichogramma* spp, with artificial diets, containing hemolymph of different insects. Parasitoids and predators (insecta) of agricultural and forestry arthropod pests – P. 335–337.– 1997. (In China).
2. Li Li-ying, Liu Wenhui, Chen Chaoshian, Han Shityou, Shin Jiachi, Du Hansun, Feng shuyi. In vitro rearing of *Trichogramma* spp and *anastatus* sp in artificial “eggs” and the methods of mass production. Parasitoids and predators (insecta) of agricultural and forestry arthropod pests – P. 344–357.– 1997. (In China).
3. Grenier S., Liu W. H. Antifungals: mold control and safe levels in artificial media for *Trichogramma* (Hymenoptera, Trichogrammatidae).– *Entomophaga*,– 35: 285–290.– 1990.
4. Жумаев Р. А. In vitro rearing of trichogramma (Hymenoptera: Trichogrammatidae) // *European Science Review* No. 9–10. Austria, Vienna – 2016.– P. 11–13.
5. Жумаев Р. А. The technology of rearing Braconidae in Vitro in biolaboratory // *European Science Review* No. 10. (DOI: <http://dx.doi.org/10.20534/ESR-17-3.4-3-5>).Austria, – Vienna – 2017.– P. 3–5.
6. Жумаев Р. А. Массовое размножение трихограммы на яйцах хлопковой совки в условиях биологической лаборатории и ее применение в агробиоценозах // *Халқаро илмий-амалий конференция “Ўзбекистон мева-сабзавот маҳсулотларининг устунлиги” мақолалар тўплами.* – Тошкент: – 2016.– С. 193–196.

Saidov Istam Rustamovich,
 assistant of professor, in the Department of Plant
 Protection from Pests and Quarantine
 Khimsanbaev Xojimurod Xamrakulovich,
 professor, Department of Plant protection
 from pests and quarantine
 Rustamov Atxam Axmatovich,
 Ph D., degree, Department of Plant protection
 from pests and quarantine
 Joxongirov Nozimxon,
 Bachelor degree, Department of Plant protection
 from pests and quarantine
 Jumaev Rasul Axmatovich,
 associate professor, In the Department of Plant
 Protection from Pests and Quarantine
 Toshkent state agrarian university. Uzbekistan
 E-mail: rasul-jumaev@mail.ru
 E-mail: jumaevrasul1990@gmail.com

BIOECOLOGY, HARM OF TOBACCO TRIPS FOR THE COTTON PLANT AND MEASURE OF COUNTERACTION

Abstract: When receiving the planned harvest from cotton plant and other crops, along with application of the highest agrotechnology and other measures, their protection against pests, diseases and weeds is one of the major and necessary factors. Default carrying out measures for counteraction in a timely order, can lead up to loss in 30% of a harvest. Interpretation of literatures. Trips belong to order Thysanoptera suborder Terebrantia, family Thripidae. It is considered the frequent wrecker of a cotton plant. Except a cotton plant, it seriously damages tobacco, onions, greens and flowers. Trips settles down in young leaves and growing points of herbs of a cotton plant, thus piercing soaking damages crops. The lower part of damaged leaves, acquires a silver color, and from the injured buds, there are expanded sick leaves.

Keywords: Thysanoptera, Terebrantia, Thripidae, Thrips Tabaci, cotton, agrobiocenosis, pest, bioecology, imago.

Introduction. Along with the use of high-tech and other measures to obtain plan yield of cotton and other agricultural crops, it is necessary and crucial important to manage pests, diseases and weeds. Failure to take timely measures to control of pests, diseases and weeds can cause loss of yield up to 30%. In order to prevent this, the results of scientific and extinction research should be regularly applied to production. Only then we can harvest the crop without significant lost. This research aims

to get scientific results that will add up in to integrated pest management of one of the most important cotton sucker pest trips.

Literature review. Thrips, *Thrips tabaci* Lind 1889 (Thysanoptera: Terebrantia: Thripidae), is common pest in cotton production. In addition to cotton thrips severely damages tabaco, onion, greens and flower. Trips damages with piercing- sucking method the young cotton leaves and grows point. Damaged leaves start showing silver

colored shiny spots in the abaxial side of the leaf where later heavily damaged leaves and flowers will fall off the plant and cotton ball development slows down [1; 2; 4].

Long-term application of some insecticides selected resistant trips population for certain pesticides. In order to prevent this, it is necessary to use different chemicals that have different modes of action or belong to different chemical groups. According to Hodosiwicz (1975), average trips damage can reduce approximately 500 kg yield per hectare. Trips is a very small insect, its length is 0.8–0.9 mm. The nymph has a long, large, rounded egg holder. The mature insect has two pairs of narrow wings [1; 3; 5].

The mouth part of trips is piercing-sucking and it is short. Instar trips color is bit duller compared to imago trips, wingless and ovipositor is not developed on female trips. Moreover, instar trips compound eyes are not developed well during this period, only couple ommatidia are developed and 6 segmented antenna. It overwinters on the litter and upper surface of soil. In March it wakes

up from wintering and starts developing in weeds where later it moves to cotton. Female trips longevity is thirty days and fecundity is 100 eggs oviposited in to plant tissue. After nymph hatches from the egg it starts feeding along the leaf veins. The nymph moults for four times and becomes an imago. Trips gives seven to eight generations in Uzbekistan condition.

Control measures. Cleaning fields from litter and plant material, and agrotechnical measures, as well as cotton seeds treatment with Gaucho, Dalucho, Avalanche-5kg/t, Gaucho-M-8–10kg/t before planting in the trips infested field helps to decrease trips population. Chemical method was selected for over-research which is one of the vital parts of integrated pest management. As an insecticide 20% Sumi-Alfa e.c. was selected for trips control with the dose of 0.1-liter per hectare, S6524 variety used. The experiments were conducted in Piskent district of Tashkent region. During spray temperature was 28 °C and wind speed was 2 m/sec. The results shown in (table 1).

Table 1. – Economic efficacy of 20% Sumi-Alfa e.c insecticide against trips in cotton production in Piskent district, Tashkent region

№	Option	Spray Rate liter per hectare	Number of pest in one plant				
			Before spray	After spray			
				3 days	7 days	14 days	21 days
1.	20% Sumi-Alfa e.c	0.1	12.6	0.7	2.1	7.85	11.0
2.	Standart Detsis 10% e.c.	0.2	11.8	0.6	2.1	7.0	10.4
3.	Control Untreated		10.7	18.2	21.4	25.6	29.8
Biological efficacy (%)							
1.	20% Sumi-Alfa e.c	0.1	–	92.4	83.2	37.9	12.7
2.	Standart Detsis 10% e.c.	0.2	–	94.9	82.1	40.7	11.9
3.	Control Untreated	–	–	170	200	239	278.5

The results show that 0.1 l/ha Sumi-Alfa 20% e.c. is biological efficacy in the first three days was the highest result, 92.4%, 83.2%, respectively. The insecticide was remaining biological efficiency for two to three days and started to decline in the rest of the day. If control was done on time and in the optimal environment condition it can be achieved high efficiency. We can save up to 0.5 tons of cotton that can be lost as a result of trips damage.

Conclusion. The main purpose of this research was to find a new highly biological effective insecticide for control of trips and ration of chemical in order to prevent resistance buildup of pest. The highest percentage of biological efficacy was observed on both standard and newly tested insecticides, 94.9% and 92.4% after 3 days. Using these insecticides controls trips in cotton production and prevents of approximately half a ton yield lost.

References:

1. Hasanov B.O. Cotton pests and control measures. – Tashkent, – 2001. – 36 p.
2. Alimammedov S. N., Xojaev Sh. T. Cotton pests and control measures «Mehnat».- Tashkent.- 1991. – 198 p.
3. Hasanov B. O. and et al. Cotton pests, diseases and weeds control. «University». publisher – 2002.– 34 p.
4. Xojaev Sh. T. Entomology, Agricultural pest management and agROTOXICOLOGY. «Navruz» publisher – Tashkent. – 2013.– P. 110–112.
5. Yanhitov V.V. Agricultural pests and management of them in Central Asian. – Tashkent. – 1963. – 168 p.

Izzatullaev Z. I.,
professor, of the Department of Ecology
Samarkand State University,
E-mail: zizzat@yandex.ru
Kudratov Z. A.,
assistant, of the Department of Ecology
E-mail: q-jasurjon@mail.ru

SPECIES COMPOSITION, ORIGIN AND ECONOMIC SIGNIFICANCE OF GASTROPODS (MOLLUSCA, GASTROPODA) OF THE NURATA MOUNTAIN RANGE (UZBEKISTAN)

Abstract: The article contains materials on the species composition, origin and economic significance of mollusks as pests of agricultural crops and intermediate hosts of helminths of the Nurata mountain range. In this area, 53 species of mollusks belonging to 29 genera and 18 families and two subclasses (*Pulmonata* and *Pectinibranchia*) are found.

Keywords: Nurata mountains, gastropods, species composition, pests of agricultural crops, intermediate hosts of helminths.

Introduction. The Nurata Mountains are located on the territory of Uzbekistan and occupy the western part of the Pamir-Alai group of mountains and disintegrate into the northern and southern parts. In the north there are Kuitash mountains. They extend to the Sangizar River, the only river flowing from south to north in Uzbekistan. The length of the mountain is 70 km and the altitude is 1260 m above sea level. ur. seas. The average part of the Nurata Mountains is relatively high and equal to 1750 m. However, there are also higher elevations, for example, the Zargar Upland, whose height is 2169 m. Altogether, the northern and western parts of the mountains are low, the average height is 900–1000 m.

The southern Nurata mountains consist of several small Gubdintag mountains, Karagchitag, Aktag and Koratag. Gastropods, common in this area, fall into two ecological groups: terrestrial and aquatic inhabitants. Among them there are pests of plants, intermediate hosts of helminths, leading to serious diseases of large and small cattle, birds and humans – daveniozo, fascioliasis, prostrogellosis, etc. Here also live rare and relic mollusks. Therefore, a comprehensive study of them represents both theoretical and practical interest and is relevant.

Materials and methods of research. The materials for the article were personal collections of authors for 1976, 2007–2016. from the territory of the Nurata ridge.

In total, collected and processed, more than 180 samples containing more than 1,000 shellfish.

Results and its discussion. As a result of our research [1; 2] and the processing of literary sources [5; 6] 53 species of gastropods belonging to 29 genera and 18 families and 2 subclasses (*Pulmonata* and *Pectinibranchia*) were found in the territory of the Nurata Ridge. Below is given their systematic composition.

Class *Gastropoda*

Subclass: *Pulmonata*

Terrestrial mollusks

Suborder *Stylommatophora*

Order: *Succinidae*

Family *Succineidae*

Genus *Novisuccinea* Pilsbry, 1848

N.evoluta (Martens, 1979)

Genus *Oxyloma* Westerlund, 1885

Ox.elegans (Risso, 1826)

Order *Geophila*

Family *Cochlicopidae*

Genus *Cochlicopa* A. E.I.Ferussac, 1821

C.lubrica (Muller, 1774)

C.nitens (Gallenstein, 1852)

Family *Pyramidulidae*

Genus *Pyramidula* Fitzinger, 1833

Prupestris (Drap., 1801)

- Family *Vertiginidae*
 Genus *Vertigo* (Muller, 1774)
V.pygmea (Drap., 1801)
 Genus *Truncatellina* Lowe, 1852
T.callicratis (Scacchi, 1833)
 Family *Chondrinidae*
 Genus *Chondrina* Reichenbach, 1828
C.granum (Drap., 1801)
 Family *Orculidae*
 Genus *Sphyradium* Charpentier, 1837
S.doliolum (Brugieri, 1792)
 Family *Pupillidae*
 Genus *Gibulinopsis* Germain, 1919
G.signata (Mousson, 1873)
G.nanosignata Schil.et Izzat., 1980
 Genus *Pupilla* Turton, 1931
P.muscorum (L.1758)
P.triplicata (Studer, 1820)
P.turkmenica (Boettger, 1889)
 Family *Valloneidae*
 Genus *Vallonia* Risso, 1826
V.pulchella (Muller, 1774)
V.costata (Muller, 1774)
 Family *Buliminidae* Clessin, 1879
 Genus *Pseudonapaeus* West., 1887
P.albiplicatus (E. Mart, 1874)
P.sogdianus (Martens, 1874)
Peremita (Benson,1849)
P.starobogatovi Pazilov, 2003
 Genus *Condrollopsina* Lindholm, 1925
C.intumescens (E. Mart., 1874)
 Genus *Geminula* Lindholm, 1925
G.continens (Rosen, 1892)
 Family *Perussaciidae*
 Genus *Caciliodes* I. B.L.Ferussac, 1814
C.acicula (Mull., 1774)
 Family *Agriclimacidae*
 Genus *Deroceras* Rafinesque, 1820
D.laeve (Mull., 1774)
D.agreste L., 1758
 Family: *Parmacellidae*
 Genus *Candaharia* Goodwin – Austen, 1888
C.izzatullaevi Lich.et Wiktor, 1980
C.levanderi (Simroth, 1901)
C.roseni (Simroth, 1912)
C.kaznakovi (Simroth, 1912)
- C.aethiops* (Westerlund, 1896)
C.rutellum (Hutton, 1849)
 Family *Euconulidae*
 Genus *Euconulus* Reinhardt, 1883
E.fulvus (Muller, 1774)
 Family *Gastrodontidae*
 Genus *Zonitoides* Lehmann, 1862
Z.nitidus (Muller,1774)
 Family *Ariophantidae*
 Genus *Macrochlamys* Benson, 1832
M.schmidti (Brancsik, 1891)
 Family *Vitrinidae*
 Genus *Phenacolimax* Stabile, 1859
Ph.annularis (Studer, 1820)
 Family *Hygromiidae*
 Genus *Leucozonella* Lindholm, 1927
L.rufispira (E. Mart., 1874)
L.mesoleuca (E.mart., 1882)
L.rettei (Rosen, 1897)
 Genus *Xeropicta* Montereato, 1892
X.candaharica (L. Pfeiffer, 1846)
X.krynickyi (Krynickyi, 1833)
 Genus *Angiomphalia* Schileyko, 1978
A.regeliana (Martens, 1882)
- Freshwater molluks**
 Order *Lymnaeiformes*
 Family *Lymnaidae*
 Genus *Lymnaea* Lamarck, 1799
L.auricularia (L., 1758)
L.thiessea (Clessin, 1979)
L.truncatula (Muller, 1774)
L.bactriana (Hutton, 1850)
L.subdisjuncta (Nevill, 1878)
 Family *Physidae*
 Genus *Costatella* Dall, 1870
C.acuta (Drap., 1805)
 Family *Planorbidae*
Planorbis O. F. Muller, 1774
P.tangitarenensis Germain, 1918
Anisus Studer, 1820
A.ladacensis (Nevill, 1878)
- Subclass *Pectinibranchia*
 Order *Littoriniformes*
 Family *Belgrandiellidae* Radoman,1983
 Genus *Martensamnicola* Izzat., Sitn. et Star., 1985
M.brevicula (Mart.,1874)

M.hissarica (Shadin, 1950)

Genus *Bucharamnicola* Izzat., Sitn.et Star., 1985

B.bucharica (Shad., 1952)

Genus *Paladilhiopsis* Pavloviv, 1913

Paladilhiopsis sp.

Of the total number of 41 species of terrestrial mollusks: *Candaharica kaznakovi*, *C.roseni*, *C.izzatullaevi*, *Xeropicta candaharica* damage plants. Among them, the last two species are widely distributed in the south of the Nurata Mountains, the first of them damages vegetable crops, the second – clover. Terrestrial mollusks *Vallonia costata*, *V.pulchella*, *Cochlicapa lubrica*, *Pupilla muscorum* in Central Asia are noted as intermediate hosts of helminths, which are the cause of diseases of hasteliosis and dicrocelia [Mateokin, 1966; 4], and *Leucozonella mesoleuca*, *L.rufispira* protostrongylosis [5]. However, only *X.candaharica* serves as an intermediate host of 4 species (*Protostrongylus rufescens*, *Pirailleti*, *P.davtiani*, *P.caprae*), and *Pseudonapaeus sogdianus* is the causative agent of mammalian dicrocoliosis [5].

Aquatic mollusks from the family *Lymnaeidae*: *Lymnaea auricularia*, *L.bactrina* and *L.subdisjuncta* serve as an intermediate host for *F.gigantica*, for *F.hepatica* – *L.truncatula*, *L.thisseae*. The last two species and *L.auricularia* are widely distributed in the reservoirs of the investigated region.

Many species of land mollusks are widely distributed in the Turkestan Zarafshan range, in the mountains of western Tien Shan and Gissaro-Darvaz. *Pseudonapaeus starobogatovi*, described from the surroundings of Nakruta in the south of the Nurata Mountains, is endemic to this territory [5].

Species that are widespread in the mountains of Nurata and Gissar Range: *X.candaharica*, *Gibbulinopsis signata* and *Geminula continens* are of ancestral origin to the Anterior Asian species. Known from Nurata and Kopetdag: *Chondrina granum*, *Pupilla turkmenica* and *Xeropicta krinskii*, settled in the area from the xerophilous territories of Ancient Middle-earth. All of the above species settled in the Nuratah region in the Neogene in connection with the uplift of the mountains and along with the spread of the plants. Like throughout Central Asia, the Nurata mountain range was elevated in the Neogene. In the waters (in springs, key springs, sai and irrigation canals), the Nurata range of the family *Lymnaeidae* inhabited widely distributed in the Palearctic – *L.auricularia*, from the ter-

ritories of Europe and Siberia – *L.truncatula*, *L.fontinalis*, Fam. *Planorbidae* – *P.planorbis*. It also inhabits the widely distributed in Central Asia – *Lymnaea bactriana*, *L.subdisjuncta*, *P.tangitarensis* and *Anisus ladasensis*. Widely distributed in the springs and key sources of the Syr Darya, Zarafshan and Amu Darya basins, small pre-nasopharyngeal mollusks of Fam. *Belgrandellidae*: *Martensamnicola brevicula*, *M.hissarica*, *Bucharamnicola bucharica* also settled from the above reservoirs, and from the reservoirs of the Ancient Middle-Earth waterways penetrated – *Costatella acuta*, belonging to the Family *Physidae*.

Thus, the fauna of the mollusks of the Nurata Mountains, like the whole Malachofauna of Central Asia, was formed in the Neogene, in the middle of the Tertiary time. In the Miocene penetration into the waters of European species in this region increased. Penetration of aquatic mollusks in the Miocene and Pliocene increased the status of Palearctic species. From the north, the West Siberian species penetrated, from Europe and the northeast, the species of the subregion of the Siberian Palearctic Center. In the southern regions, in the Amu Darya basin, the species of Southern Europe and the Near East spread [1].

Based on the above, we can draw the following conclusions:

- Among the terrestrial mollusks of the Nurata Range, plant pests of agricultural crops and intermediate hosts of helminths are widespread, leading to animal diseases – davenioz, protostrongylosis;
- From the aquatic clam family. *Lymnaeidae*: *L.truncatula*, *L.thisseae* are intermediate hosts – *Fasciola hepatica*; *L.auricularia*, *L.subdisjuncta*, *L.bactriana* – *F.gigantica*;
- Terrestrial mollusk – *Pseudonapaeus starobogatovi* is considered endemic to this territory, the shell of which is left-handed and can be used in the evolutionary constructs of mollusks;
- The keys and springs of the Nurata Mountains are home to endemic species of the Amu Darya basin of the genus *Martensamnicola* and *Bucharamnicola*, which belong to the family *Belgrandellidae*, are the remains of tertiary fauna, when the tropical climate prevailed in this territory;
- On the territory of the Nurata Mountains mollusks live from the Neogene of the Cenozoic era (Miocene and Pliocene).

References:

1. Izzatullaev Z. Aquatic mollusks of Central Asia and adjacent territories (composition, peculiarities of lifestyle, distribution, zoogeography and history of fauna formation, economic significance). Avtoreferat disertacii na soiskaniye uchonoy doktora biologicheskikh naus. ZIN AN SSSR.– Leningrad,– 1987.– 45 p (In Russian).
2. Izzatullaev Z. I., Kudratov Zh. A. Species composition, ecological complexes, distribution and protection of gastropod mollusks of springs and keys of the Nurata ridge. *Uzbekskiy biologicheskij zhurnal*,– 2012 a.– No. 2.– P. 31–35 (In Russian).
3. Izzatullaev Z. I., Kudratov Zh. A. The composition of fauna and zoogeographical connections of gastropods (Mollusca, Gastropoda) of the Nurata ridge. *Uzbekskiy biologicheskij zhurnal*,– 2012 b.– No. 4.– P 33–35. (In Russian).
4. Matyokin P. V., Turlygina E. S., Shalaeva N. M. To the biology of larvae of sheep and goats and the connection with the epizootology of protostrongyloidosis in Central Asia. *Zoologicheskij zhurnal*,– 1954.– 33.– No. 2.– P. 373–384. (In Russian).
5. Pazylov A., Azimov D. A. Terrestrial mollusks (Gastropoda, Pulmonata) of Uzbekistan and adjacent territories.– T.: FAN,– 2003.– P. 3–316. (In Russian).
6. Starobogatov Ya. I. New species of gastropods from springs and subterranean waters of Middle Asia. In: Fauna of sediment waters of Middle Asia. *Trudy Zoologicheskogo Instituta AN SSSR*,– 1972.– 50.– P. 165–172. (In Russian).

Imomov Otabek Normirzoyevich,
Department of Physiology and Valeology
Namangan State University, Namangan, Uzbekistan
E-mail: Otabek.bio@mail.ru

BIOLOGICAL AND ECOLOGICAL FEATURES OF *ARTEMISIA SOGDIANA* BGE IN THE CONDITIONS OF CHUST – PAP STEPPES IN FERGHANA VALLEY

Abstract: In this paper it is given information about biological and ecological features of plant *Artemisia sogdiana* Bge. in the Chust – Pap steppes in Fergana valley in the Republic of Uzbekistan. Especially, were studied of seed germination, vegetation, water regime and adaptation to the region.

Keywords: *Artemisia sogdiana* Bge, steppes condition, ecosystem, biological and ecological features, vegetation, water regime.

Introduction. Nowadays, there are actual problems influence process climate change to increasing air temperature, effect anthropogenic factor to desertification. Very important to be settle these problems through study ecosystems of these territories, especially, cover plants vegetation, and return those systems with useful and fodder species plants and rational use them in livestock. The Chust-Pap steppes like these territories and located in the Ferghana Valley in the Republic of Uzbekistan and the official in Namangan region, these territory one of the largest steppes in the Ferghana valley which are used by farmers as the autumn, winter and spring pasture for small horned beasts. The climate of the region is like to desert, dry, long lasting hot summer, and the moisture does not long lasting in autumn and spring and amount of precipitation is less. The main reason for this, the steppes are surrounded with the mountains of Kurama from north and northern-west, this relates to the blocking of wet air that coming from northern-west.

Researches were from 2009 to 2013 in Chust – Pap steppes. According to many years of climate data, precipitation in the summer is almost impossible. In July, the average air temperature from + 24 °C to + 27 °C. Maximum from + 40 °C to + 45 °C. The winter is so not frost, the average temperature in January is from – 1 °C to – 2 °C, and the minimum temperature is from – 25 °C to – 30 °C. The average many years temperature is from + 13 °C to + 14 °C. The years spent on experiments was in 2009 year + 15.2 °C; in 2010 year + 14.9 °C; in 2011 year + 15 °C; in 2012 year 12.9 °C; in 2013 was 14.1 °C [4]. Many years of average amount of precipitation is from 195 mm to 200

mm. The years spent on experiments was in 2009 year 135,5 mm, in 2010 year 277.1 mm, in 2011 year 221.9 mm, in 2012 year 229.2 mm, in 2013 year 264.8 mm [4].

It is important to study adaptation plants to dehydration for use in artificial enrichment of ecosystems. In the among species plants genus *Artemisias* have a special place used to regenerate the territory ecosystem.

Aim of the work to study biological and ecological features *Artemisia sogdiana* Bge., particularly seed germination, plant's vegetation, water regime.

Subject of the research: *Artemisia sogdiana*. Family Compositae, perennial half – bush, height plants 15 to 20 cm long. In favorable conditions, the generative branches are from 40 to 50 cm. The color of the plant is white – gray. Spread in Central Asia (Western Tyan – Shan, South-Western Pamir Alay, Afghanistan) (Flora of Uzbekistan. IV book.) Plant grows in finely ground clay and crushed stone soils in mountain and foothill areas. All part of the plant including the stalk white – gray, green, generative stems grow to 40 cm in a year.

Literature review. We can see researches in *Artemisia sogdiana* in cultural and natural conditions in works R. S. Vernik [2] and T. U. Rakhimova [5]. The biological and ecological features of the plant is mostly studied in the steppes of Chartak in Namangan region. Chartak steppes differ from Chust – Pap steppes in terms of their soil and climate.

Methods. Studying the seed germination is done by the base of methodology that recommended by Shamsutdinov [6]. Phenological observations in natural and cultural conditions are based on the methodology of

Beydeman [1]. Water scarcity of plants leaf by methodology I. Catsky [7], transpiration intensity by methodology A. A. Ivanov [3].

Results and discussion

Latent period. It is the hidden period and the germination of plants in laboratory condition was from 67% to 70% in 2009–2010, and the germination in field condition was 30.7% that 0.5 cm sowed in late autumn.

Germination period. (sprout plants) The Seeds sowed in November (2008) and December (2009), were germinated in the first decade of March. The length of the stems is 4–5 mm, diameter 1.5–2 mm. The germination of the whole seeds was 7 to 9 days.

Leaf development (main shoot). The real leaves and stalks appeared in the third decade of March. On the second decade of April, the heights of the stems were 2 to 3 cm. On the first decade of April the initial leaves being kept at the down side of the stems was 7 to 9 permanent leaves appeared. The length of these leaves 1–2 cm and breadth 0.8–1.2 cm, and seeds leaves are kept between 20–25 days.

Formation of side shoots / tillering and development of harvestable vegetative plant parts. We can see this phase in May and June months of the year. During this time, the plant grows actively in a cultivated state its height is up to 30–40 cm. During this period, the second ordered stem of the plant also emerges. The roots reach up to 25 cm. The leaves are gray-green, shaved, cut twice, with a length of 3 to 5 cm (with point), width 0.8 to 1.2 cm, and leaves in the bottom of the stem to 7 cm.

Flowering and development of fruit. The budding may continue from May to August. Relating to climate blooming and budding can be till September and October. If summers comes, it will be postponed. In summer

the leaves are fallen in many cases. A basket of it is 5–7 flowered, rolled leaf is 4–6 rows. In November, fruits are formed and the seeds are ripe in the second half of the month, and their generative shoot will die. The seeds are 2–2.2 mm long. With the arrival of spring, more generative branches grow again. If spring and summer are dry and water is insufficient and hot as well, only vegetative body grows from early spring to late autumn.

The root system reaches to 250 cm deeper in two or more years old plants. The side roots form two tiers. The upper half is 0 to 20 cm, the lower half 60 to 80 cm.

According to the information in literature, the productivity of this plants in natural conditions does not exceed from 3 centner/ha. In cultural conditions it is equal to 7–9 centner/ha. The abundance of the seeds cultivated conditions is up to 30 kg/ha.

If the weather conditions will be favorable in October and November the vegetative shoots and leaf grows. In cold winter also may grows green leaves emerge from root cane. The main function of the vegetative shoot is photosynthesis and form an organic substance that collects up in the roots and prepares the base for the grow of the generative shoot. The weather condition autumn comes well, the vegetative shoot also grows well and collects up many nutrients and its generative shoots will improve in the spring.

The main factor determining the plant's climatic adaptation is its water regime. The ability to store water in the assimilational shoots this plants related with vegetative phase and with weather condition in different years and changed during the day (Fig. 1). In April on average it was 70.23% throughout the day, this dropped off for 10% in May and it was 60%, in June it was 51.2%, 42.1% in July.

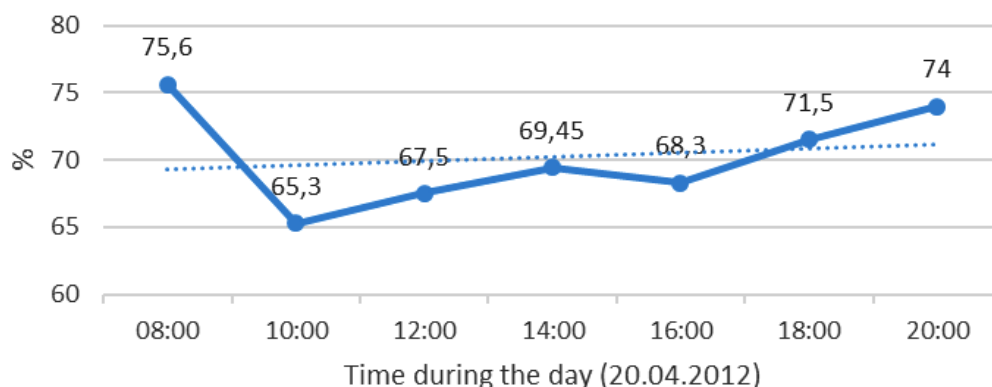

Figure 1. Change the ability to store water in the assimilational shoots *Artemisia sogdiana* during the day (%)

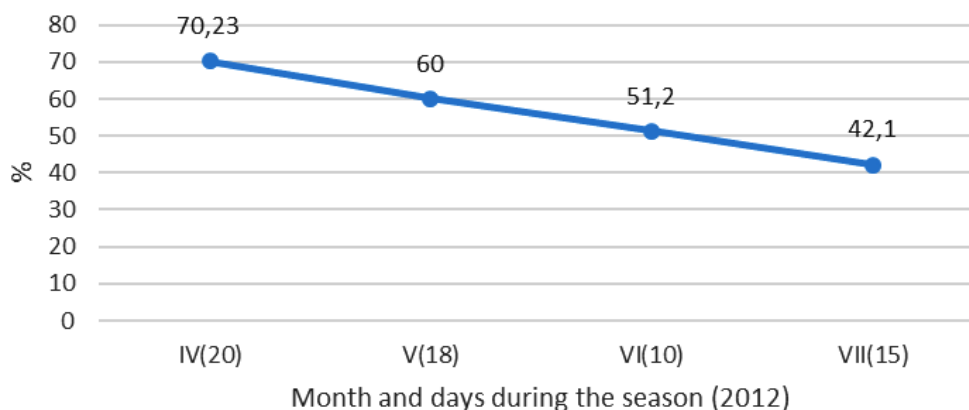

Figure 2. Change the ability to store water in the assimilation shoots *Artemisia sogdiana* during the season (%)

The 2-year-old plants in the 2012 year will have a maximum of 75.6% (Fig. 1) in April, and will vary slightly during the whole day. From April to June, the ability to absorb water from the assimilated shoot is reduced to 28.1% (Fig. 2). After that plant's leaves are dry up but in third decade August and first decade September it continue the vegetation. This is a process related with plant adaptation.

The main factors limiting the vital activity of plants are the lack of high temperatures and moisture in the Chust – Pap hills. For study to the types of plants for inconvenient conditions, we should to identify plants scarcity of water. With the help of this, it can be used to determine the reaction of plants to shortage of water.

The water scarcity of the *Artemisia sogdiana* is different while days and in different seasons of the season. According to three years results, the average monthly rate was 20% in May, 33% in May, and 43% in June. Maximum water deficiency was observed in July, up to 46%.

The intensity of transpiration of the plant is so not high, in April the during day was 275 mg/g, 376 mg/g in May, 355 mg/g in June, and 326 mg/g in July.

Artemisia sogdiana is well-adapted to the Chust-Pap rangelands environment, and it is considered to be prospective plants in the enrichment of degraded pastures with fodders; have economic importance in increasing yields of the pastures.

References:

1. Бейдеман И. Н. Методика изучения фенологии растений и растительных сообществ. – Новосибирск. – 1974. – 153 с.
2. Верник Р. С., Маркова Л. Е., Рахимова Т. Т. Биологические особенности вводимых в культуру кормовых растений // Сб.: Эколого – биологические основы создания искусственных пастбищ и сенокосов на сдыхах Ферганской долины. – Ташкент. Фан. – 1977. – С. 59–61.
3. Иванов Л. А. и др. О методе быстрого взвешивания для определения транспирации в естественных условиях. – Ташкент. Ботан. журн., – Т. 35. – № 2. – 1950. – С. 171–185.
4. Научно-прикладной справочник по климату Узбекистан. Многолетние данные. в. 14. Узбекистан. Кн. 2. – Т. Узгидромет. – 2015. – 149 с.
5. Рахимова Т. У. Экология растений адырной зоны Узбекистана. Част-1. – Ташкент. Университет, – 1997. – С. 193–199.
6. Шамсутдинов З. Введение в культуру пустынных кормовых растений. – Ташкент. Мехнат. – 1987. – 85 с.
7. Catsky I. Determination of water deficit in disks cut of foliage leaves // Bot. Caz. – Vol. 53. – 1960. – P. 76–78.

Ismatova Zulaykho Asadovna,
teacher, of the Jizzakh State University
pedagogical Uuniversity
E-mail: anvar.ilmiy@mail.ru

SYSTEMATIC ANALYSIS OF INDICATOR SABORBINE SPECIES OF ALCOHOLS OF THE SANGZAR RIVER

Abstract: The indicator saprobic algal species of the Sangzar River have been investigated and systematized for the first time. Identified 522 algae from them, 134 indicator saprobic species and varieties that belong to 53 genera, 28 families, 17 orders, 11 classes and 6 department (Cyanophyta, Xanthophyta, Chrysophyta, Bacillariophyta, Euglenophyta, Chlorophyta).

Keywords: Sangsar River, algae, systematic analysis, indicator, Cyanophyta, Xanthophyta, Chrysophyta, Bacillariophyta, Euglenophyta, Chlorophyta.

Since ancient times, mankind has been using natural resources for its needs and increasingly taking them from nature. This contributes to a partial change in nature. Especially, improper use of water, emissions of industrial waste leads to an increase in the pollution of the river. As a result, the species composition of aquatic flora and fauna is reduced. This poses a great threat to their development and spread and helps to reduce species and varieties. Algae that are widespread in nature are of great importance, since they are used in many branches of the national economy.

We researched 522 species and varieties in the Sangzar River and studied their distribution along the river, seasonal development, with the help of indicator saprobic algae, the degree of water pollution was revealed.

The indicator saprobic algal species of the Sangzar River have been investigated and systematized for the first time. Identified 522 algae from them, 134 indicator saprobic species and varieties that belong to 53 genera, 28 families, 17 orders, 11 classes and 6 department (Cyanophyta, Xanthophyta, Chrysophyta, Bacillariophyta, Euglenophyta, Chlorophyta) (Table 1).

The content of the indicators is about 25.67% of the total number of algal taxa discovered by us (522).

The main species among the saprobic organisms can be considered representatives of diatom algae – 93 species or 69.40% of their total content (134). Then follows the green algae – 18 species, or 13.43%, blue – green – 15 or 11.19%, euglenic – 6 or 4.48%, Xanthophyta, and Chrysophyta – 1 species or 0.75%.

Table 1. – Systematic analysis of indicator saprobic species and varieties of algae of the Sangzar River

Department of algae	Amount								Percentage of total number of species
	Classes	Order	Family	Births	Species	Variation	The form	Total	
Cyanophyta	2	3	6	10	14	1	–	15	11.19%
<i>Rhodophyta</i>	–	–	–	–	–	–	–	–	–
Xanthophyta	1	1	1	1	1	–	–	1	0.75%
<i>Chrysophyta</i>	1	1	1	1	1	–	–	1	0.75%
<i>Bacillariophyta</i>	2	4	8	26	76	16	1	93	69.40%
<i>Euglenophyta</i>	1	1	1	3	6	–	–	6	4.48%
<i>Chlorophyta</i>	4	7	11	12	17	1	–	18	13.43%
Total:	11	17	28	53	114	18	1	134	100%

Taxonomic analysis of the composition of the Sangzar indicator saprobic algae shows that 93 noted species and varieties of diatoms are united into 26 genera, 8 families, 4 orders, 2 classes (Table 2).

The class Pennatophyceae unites only 69 indicator saprobic species and varieties in the department, and Centrophyceae – 7 species [3].

Among the orders Raphinales includes 5 families and 22 genera. Naviculaceae West has a large number of species among the families. – 40 species and varieties. The most generous genera are: Navicula Bory. – 14, Nitzschia Hass. – 12, Cymbella Ag. – 9.

Table 2. – The systematic composition of the indicator saprobic algae of the Bacillariophyta of the Sangzar River

Classes	Order	Family	Births
<i>Centrophyceae</i>	<i>Discooidales</i>	<i>Coscinodiscaceae</i> Kuetz.	<i>Melosira</i> Ag.
			<i>Cyclotella</i> Kuetz.
			<i>Stephanodiscus</i> Ehr.
	<i>Solinioidales</i>	<i>Soleniaceae</i> Schutt.	<i>Rhizosolenia</i> Ehr.
<i>Pennatophyceae</i>	<i>Araphinales</i> Schutt.	<i>Fragilariaceae</i> (Kuetz) D.T	<i>Meridion</i> Ag.
			<i>Diatoma</i> D.C.
			<i>Fragilaria</i> Lyngb.
			<i>Ceratoneis</i> Ehr.
			<i>Synedra</i> Ehr.
	<i>Raphinales</i>	<i>Achnanthaceae</i> (Kuetz) Grun.	<i>Cocconeis</i> Ehr.
			<i>Achnanthes</i> Bory.
			<i>Rhoicosphenia</i> Grun.
		<i>Naviculaceae</i> West.	<i>Stauroneis</i> Ehr.
			<i>Navicula</i> Bory.
			<i>Pinnularia</i> Ehr.
			<i>Caloneis</i> Cl.
			<i>Gyrosigma</i> Hass.
			<i>Amphora</i> Ehr.
			<i>Cymbella</i> Ag.
			<i>Didymosphenia</i> M. Schmidt.
			<i>Gomphonema</i> Ag.
			<i>Epithemiaceae</i> Hust.
			<i>Nitzschiaceae</i> Hass.
			<i>Surirellaceae</i> (Kuetz.) Grun.
		<i>Denticula</i> Kuetz.	
		<i>Bacillaria</i> Gmelin.	
		<i>Nitzschia</i> Hass.	
		<i>Cymatopleura</i> W. Sm.	
		<i>Surirella</i> Turp.	
Total: 2	4	8	26

The results of the analysis of the species composition of representatives of the Chlorophyta department found in the Sangzar River indicate that 18 indicator saprobic species and a variety of algae are combined into 12 genera belonging to 11 families, 7 orders and 4 classes [4, 7, 8] (*Chlorococcophyceae*, *Ulotrichophyceae*, *Siphonocladophyceae*, *Conjugatophyceae*) (Table 3).

The families of *Ulotrichaceae* Kuetz are the most numerous species of saprobity (4), *Cladophoraceae*

(Hass.) Cohn. (3), the rest of the family is represented by a small number – from 2 to 1 species.

Among the genera of green indicator saprobic algae are rich in species of *Ulothrix* Kuerz (4), *Chlorella* Beijerinck (2), *Cladophora* Kuetz (2), *Spirogyra* Link (2); the rest of the genera consist of 1 species.

According to the structure of representatives of the department of Cyanophyta, it can be judged that the detected species and forms of indicator saprobic algae

(15) belong to 10 genera, 6 families, 3 orders and 2 classes [1, 6] (Chroococceae and Hormogoniophyceae) (Table 4).

The Chroococceae class includes 8 species or 53.33% of the total number (15).

The family of Oscillatoriaceae (Kirchn.) Elenk is the most numerous species of saprobity (6), Merismopediaceae Elenk (4).

Among the genera, the largest number of species in Merismopedia (Meyen.) Elenk. emend. (4), Spirulina Turp (2), Phormidium Kuetz (2).

Table 3. – The systematic composition of the indicator saprobic algae of the Chlorophyta department of the Sangzar River

Classes	Order	Family	Births
<i>Chlorococophyceae</i>	<i>Chlorococcales</i>	<i>Hydrodictyaceae</i> S.F. Graydumortier orth. Mut. Mohn.	<i>Pediastrum</i> Meyen.
		<i>Dictyosphaeria ceae</i> (Detoni.) G.S. West.	<i>Dictyosphaerium</i> Naegeli.
		<i>Oocystaceae</i> Bohlin.	<i>Chlorella</i> Beijerinck.
		<i>Scenedesmaceae</i>	<i>Scenedesmus</i> Meyen.
<i>Ulotrichophyceae</i>	<i>Ulotrichales</i>	<i>Ulotrichaceae</i> Kuetz.	<i>Ulothrix</i> Kuerz.
	<i>Ulvineae</i>	<i>Ulvaceae</i> Lamour.	<i>Enteromorpha</i> (Link.) Harvey.
		<i>Chaetophoraceae</i> (Harv.) De-Toni. et Levi.	<i>Stigeoclonium</i> Kuetz.
	<i>Microsporaes</i>	<i>Microsporaceae</i> Thur.	<i>Microspora</i> Thuret.
<i>Siphonocladophyceae</i>	<i>Cladophoralis</i>	<i>Cladophoraceae</i> (Hass.) Cohn.	<i>Rhizoclonium</i> Kuetz. <i>Cladophora</i> Kuetz.
<i>Conjugatophyceae</i>	<i>Zygnematales</i>	<i>Spirogyraceae</i> Randh.	<i>Spirogyra</i> Link.
	<i>Desmidiiales</i>	<i>Desmidiaceae</i> Ralfs.	<i>Cosmarium</i> Corda.
Total: 4	7	11	12

To the department of Euglenophyta are 6 species of indicator saprobic algae belonging to 3 genera (*Trachelomonas* Ehr., *Strombomonas* Defl., *Euglena* Ehr.). Among the genera, *Trachelomonas* Ehr is the largest number (4).

In the department of Xanthophyta there are only 1 species belonging to the genus *Tribonema* Derb. et

Sol., the family *Tribonemataceae* Pasch., the order of *Malleodendrales* and the class *Heterocapsophyceae* [2]. The department of Chrysophyta also has only 1 species – *Chromulina* Cienk [5].

Table 4. – The systematic composition of the indicator saprobic algae of the Cyanophyta section of the Sangzar River

Classes	Order	Family	Births
Chroococceae	Chroococcales	<i>Coccobactreaceae</i>	<i>Synechococcus</i> Naeg. <i>Rhabdoderma</i> Schmidle et Laut.
		<i>Merismopediaceae</i> Elenk.	<i>Merismopedia</i> (Meyen.) Elenk. emend
		<i>Microcystidaceae</i> Elenk.	<i>Microcystis</i> (Kuetz.) Elenk.
		<i>Gloeocapsaceae</i> Elenk. et Hollerb.	<i>Gloeocapsa</i> (Kuetz.) Hollerb. emend.
<i>Hormogoniophyceae</i>	<i>Nostocales</i> (Geitl.) Elenk.	<i>Nostocaceae</i> Kuetz. emend. (Kirchner) em. Elenk.	<i>Nostoc</i> Adanson.
	<i>Oscillatoriales</i> Elenk.	<i>Oscillatoriaceae</i> (Kirchn.) Elenk.	<i>Oscillatoria</i> Vauch.
			<i>Spirulina</i> Turp.
			<i>Phormidium</i> Kuetz.
			<i>Lyngbya</i> Ag.
Total: 2	3	6	10

Thus, in the Sangzar River there are 134 species and varieties, indicator saprobic algae, leading from which are algae Bacillariophyta, followed by Chlorophyta, Cyanophyta, Euglenophyta, Xanthophyta and Chrysophyta.

References:

1. Gollerbach M. M., Kossinskaya E. K., Polyansky V. I. The determinant of freshwater algae of the USSR. Issue. II. Blue-green algae. – M.: Soviet Science,– 1953.– 655 p.
2. Dedusenko N. T.–Schegoleva and Hollerbach M. M. The determinant of freshwater algae of the USSR. Yellow-green algae. – Moscow–Leningrad,– 1962.– 272 p.
3. Zabelina M. M., Kiselev I. A., Proshkina A. I. Lavrenko, Sheshukova V. S. The determinant of freshwater algae of the USSR. Diatoms. Issue. 4.– M.: Soviet Science,– 1951.– 619 p.
4. Kursanov L. I., Zabelina M. M., Meyer K. I., Roll Ya. V., Peshinskaya N. I. The determinant of lower plants.– Volume I. Algae.– M.: Science.– 1953.– 396 p.
5. Matvienko A. M. The determinant of freshwater algae of the USSR. Golden algae.– M.: Soviet Science,– 1954.–188 p.
6. Muzafarov A. M., Ergashev A. E., Khalilov S. The determinant of blue-green algae in Central Asia. Book 1. 2. 3.– Tashkent: Fan,– 1987.– 405 p.– 1988.– P. 406–815.– 1988.– P. 816–1215.
7. Moshkova N. A., Hollerbach M. M. The determinant of freshwater algae of the USSR. Issue. 10 (1) Green algae. Order Ulotriksovye–Ulotrichophyceae. – Leningrad: Science,– 1986.– 357 p.
8. Palamar G. M., Mordvintseva G. M. The determinant of freshwater algae of the USSR. Issue. 11 (2) Green algae. The order of Desmidia–Desmidiales (2). – Leningrad: Science,– 1982.– 620 p.

*Dolimova Surayyo Nugmanovna,
professor, Biology faculty of National University of Uzbekistan*

*Umarova Gulbahor Bozorboyevna,
docent, Biology faculty of National University of Uzbekistan*

*Mukhamadzhonova Guzal Mukhamadzhonovna,
docent, Biology faculty of National University of Uzbekistan*

*Kuziev Sherali Nasrullayevich,
teacher, Biology faculty of National University of Uzbekistan*

*Yunusova Muslima Kholmatovna,
teacher, Biology faculty of National University of Uzbekistan*

E-mail:

INFLUENCE OF SUPRAMOLECULAR COMPLEXES, SYNTHESIZED ON THE BASIS OF NATURAL COMPOUNDS ON THE MITOCHONDRIAL ENZYMES IN RATS OF VARIOUS AGES

Abstract:

Keywords:

It is known that the aging process of an organism occurs in cells of various types (nervous, hepatic, secretory, immune, etc.) and various cellular structures (mitochondria, nucleus, membranes, etc.). According to many studies, mitochondria play a special role in this process [1]. At the same time, the main focus of the researchers is on the activity of the mitochondrial genome, the functional state of mitochondria, as well as quantitative changes in the respiratory chain components [2]. With age, there is a deviation from the norm of such processes as oxidative phosphorylation, ATP synthesis, respiration, peroxide oxidation of membrane lipids, change in important energy-producing systems of cells [3]. These disorders lead to the appearance of various diseases. Therefore, in recent years, scientific research has been intensively conducted to find not only compounds that activate the functional state of mitochondria, but also substances that have antioxidant properties.

The purpose of our work was to study the age-related changes in the activity of enzymes in the respiratory

chain of liver mitochondria of rats of different ages and the effect on this process of preparations based on natural compounds preparations – **monoammonium salt of glycyrrhizic acid** and a supramolecular complex, based on megosin, a derivative of natural polyphenol gossypol – **soluble form megosin (SFM)** and **monoammonium salt of glycyrrhizic acid (MASGA)**.

Materials and methods

The experiments were performed on 3, 6, 9 and 15 month old white Wistar rats. In our work we used monoammonium salt of glycyrrhizic acid and a supramolecular complex created on the basis of megosin, a derivative of the natural polyphenol gossypol – the soluble form of megosine (SFM) and the monoammonium salt of glycyrrhizic acid (MASGA). All animals were divided into 10 groups. The first, second, third and fourth groups were 3, 6, 9, 15 monthly “young”, “mature”, “old” and “elderly” intact animals; 6-month-old rats, who received SFM and MASGA, comprised the fifth and sixth groups; The 9-month-old rats that received the SFM and MASGA were the seventh

and eighth, the 15-month groups that received the SFM and MASGA were the ninth and tenth groups.

Mitochondria were isolated by the conventional method of differential centrifugation [4].

To determine the activity of the enzymes of the mitochondrial respiratory chain of intact rats of different ages and rats treated with SFM and MASGA the method of disposable freezing-thawing of isolated mitochondria was used [5]. For this, the mitochondria were placed in the freezer at -15° – 20° C. Before the experiment, the mitochondria were thawed at room temperature, brought to liquid state and then stored at 0° C. Determination of the activity of NADH dehydrogenase and succinate dehydrogenase was carried out in phosphate buffer with 5×10^{-4} M of EDTA pH-7.4; activity of cytochrome c-oxidase in 0.2 M, pH-7.2; in phosphate buffer containing 0.001 M EDTA and 0.02 M ascorbate. The final concentration of NADH in the cell was $3 \mu\text{mol/ml}$, succinate – $10 \mu\text{mol/ml}$; cytochrome c – 1.5 mg/ml . Specific activity of the enzyme for 1 min at 25° C was expressed in nanoatoms of oxygen consumed in 1 mg of the mitochondrial protein at 25° C for 1 min.

The content of the mitochondrial protein was determined by the biuret method [6].

Results and discussions

In our previous experiments, we observed an increase in the process of lipid peroxidation (LPO) with the addition of the animal's age in mitochondria of liver of rats of various ages [7].

According to the literature, strengthening the LPO process in mitochondria, in the first place, can have a negative effect on the activity of the respiratory chain [8]. In order to clarify this state, in preliminary experiments, the activity of enzymes of the mitochondrial respiratory chain of liver of rats of various ages was studied. The results are shown in (Figure 1). As can be seen from the figure, the activity of the enzyme of the first complex of the respiratory chain – NADH dehydrogenase in 6-month “mature” rats is reduced by 9% compared to the 3-month-old control rats. Subsequently, in the mitochondria of older animals, the activity of this enzyme further decreased and in the 15-month old rats the activity of this enzyme in the mitochondria decreased by 28%.

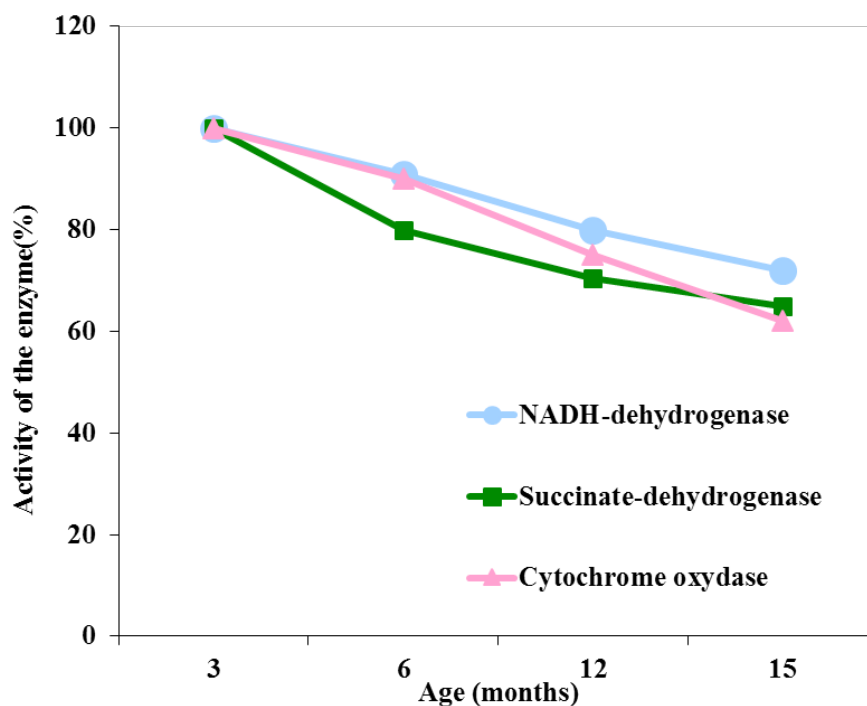

Figure 1. Activity of respiratory enzymes in liver mitochondria of rats of various ages ($n = 6$; $m \pm M$)

At determining of succinate dehydrogenase activity in rats of different ages, it was observed that this enzyme undergoes more dramatic changes with the age of the an-

imal compared to NADH dehydrogenase. For example, in 6-month-old “mature” rats, the activity of this enzyme in mitochondria decreased by 20%, in “elderly” animals

the decrease was 30%, in mitochondria of old rats the activity of succinate dehydrogenase decreased by 35%.

The activity of another enzyme of the respiratory chain, cytochrome oxidase, with the addition of the animal's age has decreased noticeably. The activity of this enzyme in the mitochondria of the "old" rats decreased by 38% compared to the young, 3-month-old rats.

Thus, as a result of the studies of this series, it was found that with the addition of the age of experimental animals, the activity of the respiratory chain enzymes is weakened. When using SFM as a stabilizing agent, this drug had a positive effect on the activity of the studied enzymes in mitochondria of rat liver. Although under the influence of SFM, the activity of the first enzyme – NADH dehydrogenase respiratory chain in the "mature" rats model is not completely restored, the enzyme activity indices are much closer to the results of the control group. Under the influence of SFM in the group of "old" rats, the activity of NADH dehydrogenase almost comes to normal (98%). In the group of "old" rats, the SFM compound has a positive effect and its effect was lower in comparison with the results of "older" rats. In our subsequent studies, it was found that the effect of the MASGA preparation on the activity of NADH dehydrogenase was lower com-

pared to SFM. According to the published data, NADH dehydrogenase belongs to the class of dehydrogenases, the dependent flavin and its prosthetic group is the coenzyme flavin mononucleotide (FMN) and in the active center of NADH dehydrogenase several non-heme iron atoms are labile with the acid, surrounds the sulfur atom and forms the center of iron- sulfur [9]. According to the literature, the above centers with the addition of the animal's age are inhibited and the activity of the enzyme is reduced.

The activity of another enzyme in the respiratory chain, succinate dehydrogenase, is restored under the influence of SFM and MASGA preparations, but this recovery in both cases was not 100%. The effect of SFM on succinate dehydrogenase, both on NADH dehydrogenase, was stronger than that of MASGA.

According to the literature data, one molecule of the succinate dehydrogenase enzyme contains one molecule of FAD bound by one covalent bond and binds to two iron-sulfur centers [9]. In one center there are two iron atoms, and in the second center there are four iron atoms. The iron of these centers in the reactions of succinate dehydrogenase due to a change in its valence (from Fe II to Fe III) participates in the transfer of electrons in the respiratory chain.

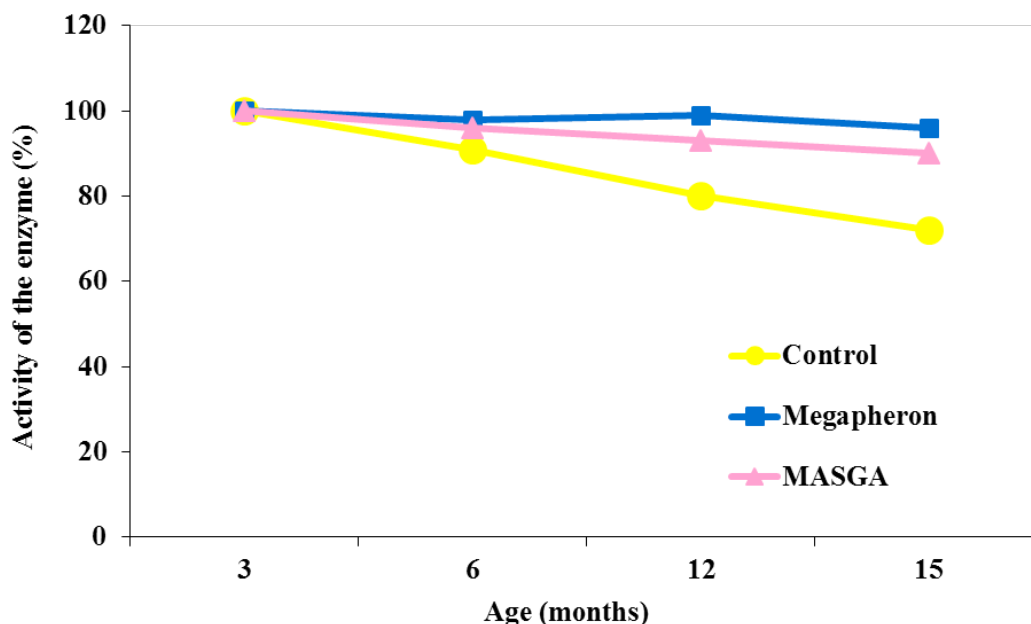

Figure 2. Effect of SFM and MASGA on the activity of the enzyme NADH-dehydrogenase of liver mitochondria of rats of different ages ($n = 6$; $m \pm M$)

Perhaps with the addition of the age of experimental animals in the mitochondria of old and elderly rats, the above-mentioned iron-sulfur-containing centers are

weakened and various changes are observed in the microenvironment of the enzyme [9].

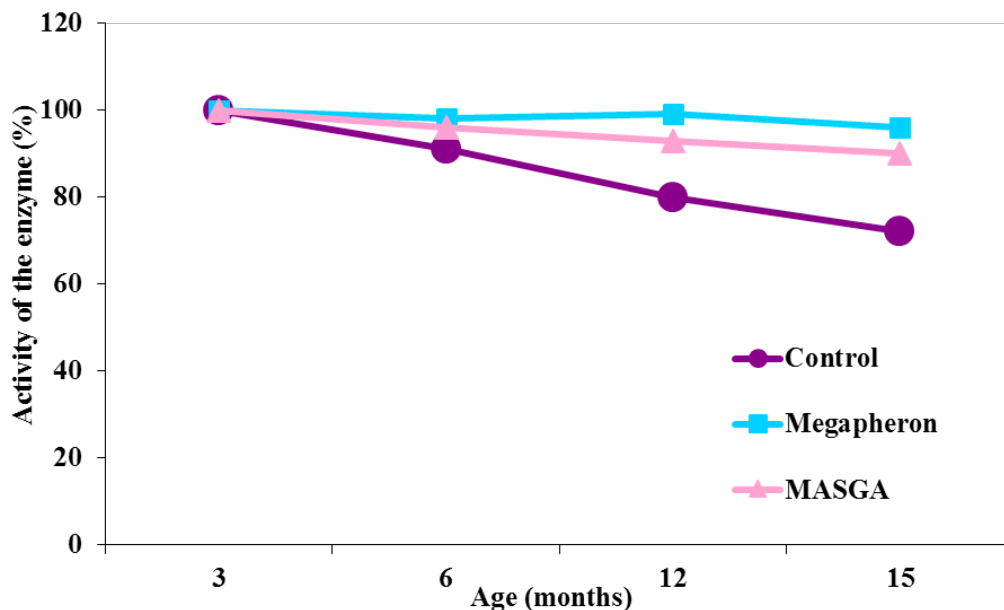

Figure 3. Effect of SFM and MASGA on the activity of the enzyme succinate dehydrogenase of liver of rats of different ages (n = 6; m ± M)

There is a restoration of the activity of one more enzyme of the respiratory chain, cytochrome oxidase, under the influence of the drugs studied, even in the group of “mature” rats, the activity of this enzyme is restored by 100%.

Cytochrome oxidase is the last component of the respiratory chain and it transports electrons from cytochrome c to molecular oxygen. Among all the compo-

nents of the electron transfer chain, only cytochrome oxidase is in direct contact with oxygen. Cytochrome oxidase is a complex protein and contains two heme, two zinc atoms, and 20–30% of the lipid component.

Cytochrome oxidase compared with other respiratory chain enzymes is very sensitive to changes in lipids and a decrease in proteins in its environment [9].

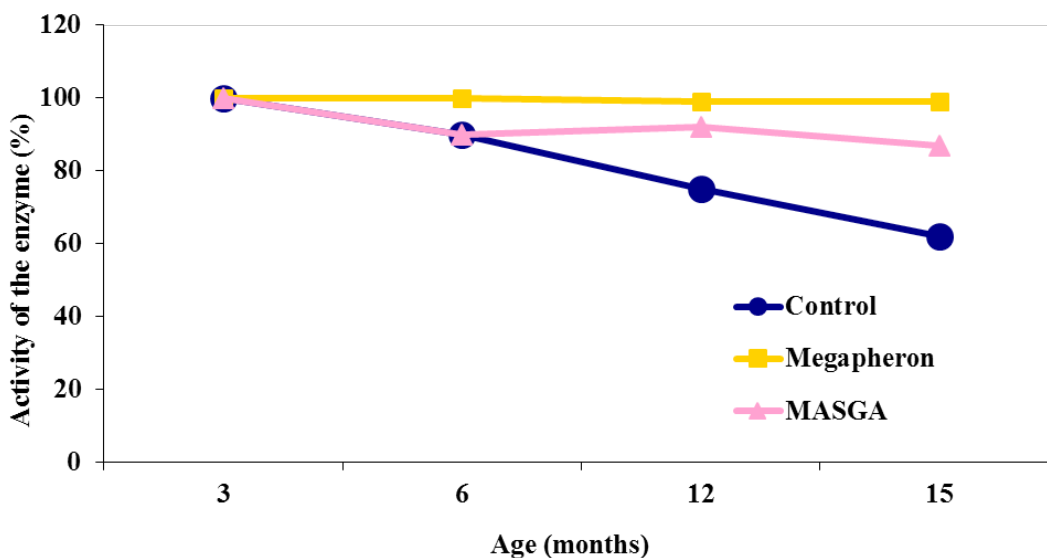

Figure 4. Effect of SFM and MASGA on the activity of the liver mitochondrial cytochrome oxidase enzyme in rats of different ages (n = 6; m ± M)

The noticeable inhibition of the enzyme observed in the old rats of our experiments, in our opinion, with the addition of age is associated not only with lipid compo-

nents, but with a violation of the center function containing heme and zinc atoms. In addition, the aging process of the body occurs with a decrease in the synthesis of

proteins. The emergence of a state of hypoproteinemia in the body of old animals may be one of the reasons for the loss of activity of the enzyme cytochrome oxidase.

According to the literature, many natural polyphenols are used as medicines in the treatment of various liver diseases [10]. In addition to the antioxidant effects of natural polyphenolic compounds, they can restore the function of the respiratory chain and the associated phosphorylation process. For example, the oliphrene preparation used in liver therapy contains a polyphenol component in its composition and participates in the transport of electrons in the respiratory chain [11].

Oliphren possesses the ability to shunt the transfer of electrons in the respiratory chain of the mitochondria, because its oxidative potential is closer to the enzyme of cytochrome oxidase. In our studies, high-performance SFM influences mitochondria as oliphrene. SFM has a

potential close to the optimum redox potential of oliphrene and comes into contact with inhibited respiratory enzymes.

Thus, the results of the conducted studies indicate that with the addition of the age of rats in the mitochondria of the liver, the activity of the enzymes of the three complexes of the respiratory chain is markedly reduced. The decrease in the activity of respiratory enzymes, in turn, disrupts the process of transfer of electrons from the chain. To correct this condition, the administration of SFM and MASGA to rats of different ages for seven days leads to the restoration of the activity of respiratory chain enzymes. Summarizing, it can be said that preparations of plant origin eliminating the inhibition of the enzymes of the respiratory chain of the mitochondria, observed during aging, exhibit a noticeable protective effect on the mitochondria.

References:

1. Zapico S. C. mt DNA Mutations and Their Role in Aging, Diseases and Forensic Sciences / S. C. Zapico, D. H. Ubelaker // *Aging Dis.* – 2013. – Vol. 4(6) Dec. – P. 364–380.
2. Reddy P. H., Reddy T. P. Mitochondria as a Therapeutic Target for Aging and Neurodegenerative Diseases // *Alzheimer Res.* – 2011. – Vol. 6.
3. Chen X. J. The search for nonconventional mitochondrial determinants of aging // *Mol Cell.* – 2011. – Vol. 42. – No. 3. – P. 271–273.
4. Schneider W. Isolation of mitochondrial from rat liver // *J. Biol. Chem.* – 1948. – V. 176. – No. 1. – P. 250–254.
5. Rakhimov M. M., Almatov K. T. Some peculiarities of degradation of polyenzyme systems of liver mitochondria of rats subjected to thermal exposure // *Biochemistry.* – Moscow, – 1977. – T. 42. – B. 10. – P. 1852–1862.
6. Scaffner W., Weisman C. A rapid sensitive and specific method for the determination of protein in delete solution // *Analyt. Biochem.* – 1973. – V. 56. – P. 502–506.
7. Serviddio G. Free radical biology for medicine: learning from nonalcoholic fatty liver disease / G. Serviddio, F. Bellanti, G. Vendemiale // *Free Radical Biology and Medicine.* – 2013. – Vol. 65. – Dec. – P. 952–968.
8. Li D., Chen H., Florentino A., Alex D., Sikorski P., Fonzi W. A., Calderone R. Enzymatic Dysfunction of Mitochondrial Complex I of the *Candida albicans* *goa1* Mutant Is Associated with Increased Reactive Oxidants and Cell Death // *Eukaryot Cell.* – 2011. – Vol. 10. – No. 5. – P. 672–682.
9. Nelson D., Cox M. *Foundations of Biochemistry of Leninger*, – Moscow, BINOM, Laboratory of Knowledge, – 2011.
10. De Feudis F. V., Drien K. Ginkgo biloba extract and CNS functions: basic studies and clinical applications // *Current Drug targets.* – 2000. – V. 1. – No. 1. – P. 25–58.
11. Rust C., Gores G. Z. Apoptosis and liver disease // *Am. J. Med.* – 2000. – V. 108. – P. 567–574.

Mirkhamidova Parida,
doctor, of biology, professor,
Tashkent State Pedagogical University named after Nizami,
E-mail: parida.mirxamidova@mail.ru,
Khujanazarov Uktam Eshtemirovich,
candidate, of biology, associate professor,
Tashkent State Pedagogical University named after Nizami,
E-mail: khuzhanazarov74@mail.ru,
Mamatqulov Doniyor Anvarovich,
candidate, of biology, associate professor,
Tashkent State Pedagogical University named after Nizami,
Ziyamukhamedova Sabohat,
candidate, of biology, associate professor,
Chirchiq State Physical Training Institute,
Mukhamedov Gofurjon Isroilovich,
doctor, of chemistry, professor,
Chirchik State Pedagogika Institute,
E-mail: rector@tvchdpi.uz

A DETERMINATION OF THE AMOUNT OF VITAMIN C IN SOME MEDICAL PLANTS GROWING IN THE SOUTH– WESTERN ZARAFSHAN MOUNTAIN RANGES

Abstract: This article involves the data about amount of vitamin C, which has an antioxidant effect, growing in the South – Western Zarafshan ridges such as *Mentha asiatica*, *Ziziphora tenuior*, *Melissa officinalis*, *Rubus sp.*, *Trichodesma incanum* and *Bunium chaerophylloides* in different seasons.

Keywords: vitamin C, carotene, ketihin, flavonol, leaf, fruit, bloom, antioxidant.

Vitamins can play a major role in the life of plants. They participate in enzymes biosynthesis, that they are main regulator of metabolism. Some vitamins participate in amino cycle metabolism [1]. Vitamin C, carotene, ketihin and flavonols participate very actively in oxidation and reduction processes in plant tissues. During this process vitamins are oxidized and refined over time [2].

Vitamin C is one of the strongest antioxidants and plays an important role in reducing oxidation. Usually the amount of vitamin C is higher in plants which are found in northern areas and highland areas than in the southern areas. Vitamin C is found all of the plants of the world. Especially, such as the fruit of *Rosa – Fructus Rosae* (*Fructus Cynosbati*), the fruits and leaves of *Ribes – Folia Et Fructus Ribis Nigri*, the leaves and fruits of forest strawberry – *Folia et Fructus Fragariae Vescae* are

rich to ascorbic acids; and extracts, drip concentrates are prepared from them and will be used for medicine [3].

Determination of vitamin C in medicinal plants is the most important biological indicator. We defined the amount of vitamin C, which has antioxidant effect, growing in the South Western Zarafshan ridges in the Kashkadarya basin and amount of vitamin C was observed in the leaves of medical plants such as *Mentha asiatica*, *Ziziphora tenuior*, *Melissa officinalis*, *Rubus sp.*, *Trichodesma incanum*, *Bunium chaerophylloides* in different seasons. Determining the amount of vitamin C was based on peculiarities of ascorbic acid by restoring of 2.6 – dixlorfenolindofenol.

Our results show, that the amount of vitamin C depends on the vegetation period of the medicinal plants (Table 1).

Table 1. – An amount of vitamin C in medicinal plants (mg/%)

№	The name of medical plants	Spring	Summer	Autumn
1.	<i>Mentha asiatica</i>	121 ± 2.2	92.4 ± 3.5	86.24 ± 5.1
2.	<i>Ziziphora tenuior</i>	81.9 ± 1	58.08 ± 2.5	57.2 ± 4.1
3.	<i>Melissa officinalis</i>	76.56 ± 3.5	92.4 ± 4	81.8 ± 3.2
4.	<i>Rubus sp.</i>	12.32 ± 4.6	49.2 ± 4.1	36.9 ± 6.1
5.	<i>Trichodesma incanum</i>	29.9 ± 2.5	60.72 ± 5.1	72.28 ± 5.3
6.	<i>Bunium chaerophylloides</i>	26.4 ± 1.8	25.5 ± 2.2	68.3 ± 3.6

The largest amount of vitamin C was found in *Rubus sp.*, and *Mentha asiatica* plants in the spring season. *Mentha asiatica* blooms in June and August, and fruits ripen in September – October. Using organs are leaves and blooms. There are ether oil and flavonol in the leaves of *Mentha asiatica* [5]. There are vitamin C and ketihin besides ether oil in Asian mint. Drip and boiled solution of mint are used in medicine. The results showed, that the highest amount of vitamin C consisted of 121 ± 2.2 mg/% in spring, 92.4 mg/% in summer, 86.24mg/% in autumn.

We observed the amount of vitamin C in the leaves of *Ziziphora tenuior*, in various seasons. In spring its amount is about 81.9 mg /% and almost it is same in the seasons of summer and autumn. *Ziziphora tenuior* is the essential medicinal plant in the field of medicine in our republic. Especially, *Ziziphora tenuior* spread in the northern and southern slopes of mountain regions. *Ziziphora tenuior* is used to cure kidney, heart, and liver and stomach–intestine disorders in people medicine. The drip of *Ziziphora tenuior* helps to improve the activity of heart, to decrease the arterial blood pressure and in curing of urine [4]. There are 2.5% of ether oil, vitamins of C, E, A in the stem, leaves and blooms.

Rubus sp. begins to bloom and ripen from July to September. Using organs are fruits, leaves and roots. There are vitamin C and carotene in the content of leaves of light blue *Rubus sp.* There are organic acids, vitamin C, plenty of celluloses, sugar substances, vitamin B and copper in the fruit of *Rubus sp.* Their branch is used by preparing boiled and drip solutions in people medicine. Our research deter-

mined that there is vitamin C in the leaves of *Rubus sp.* The received data showed, that the highest amount of vitamin C is in spring, consisting of 123.2 mg /%.

Bunium chaerophylloides blooms in June, ripens in July. There is ether oil of 2.75 – 3.0% in the fruit. There is about 20% of oil, 15% of protein substances and minerals in the fruit of it. Especially, the fruit of *Bunium chaerophylloides* is used in medicine. The highest amount of vitamin C in the leaves of *Bunium chaerophylloides* consists of 68.3 mg/% in autumn.

Melissa officinalis blooms in June – august, ripens in July–autumn. Using organs of *Melissa officinalis* are its leaves and the tip parts of branches. There are ether oil, vitamin C, urosolate and other acids in *Melissa officinalis*. The boiled solution and drips are used in people medicine. According to our results, vitamin C in *Melissa officinalis* consisted of 76.56 mg/% in spring, 92.4 mg/% in summer and 81.8 mg/% in autumn.

We defined the amount of vitamin C in *Trichodesma incanum* and vitamin C consisted of 29.9 mg /% in spring, 60.72 mg/% and 71.28 mg/% in summer. *Trichodesma incanum* spread out in Central Asia. It keeps strong alcoholics in its contents. Most alcoholics are located in its seeds. We also found that there are alcoholics in its leaves, too.

Thus, *Mentha asiatica*, *Ziziphora tenuior*, *Melissa officinalis*, *Rubus sp.*, *Trichodesma incanum* and *Bunium chaerophylloides* have vitamin C and the highest amount of vitamin C is in *Rubus sp.* and *Mentha asiatica*, this amount will be appear in the spring season.

References:

1. Devis M., Ostin D.J. Patridj D. Vitamin C. Chemistry and biochemistry. – M.: Mir. – 1999. – 168 p.
2. Xolmatov X. X., Axmedov O. A., Farmakogniziya. – T: Ibn Sino. – 2006. – 822 p.
3. Ibragimov A. Ya. Medicinal plants. – T. – 2016. – 404 p.
4. Muxtarov M. 1000 cure for 1000 illness. – Karshi, – 2009. – 271 p.
5. Khuzhanazarov U. E., Mirhamidova P., Valkhanova A., Nizamova A., Rishitillayeva N. A. To decline the biological active matter – phlovonoides in medicinal plants. European Science Review Scientific journal, – 2017. – No. 3–4. – P. 5–7.

Niyazmetov Bahodir Allaberganovich,
teacher, National University of Uzbekistan
E-mail: *physiologist0107@gmail.com*

Abdullaev Gaffurjon Rakhimjonovich,
doctor, of biological sciences,
Namangan State University
E-mail: *stress.doc@mail.ru*

Babadjanova Sayyora Khushnutovna,
candidate, of biological sciences, docent

Urgench State University
E-mail: *sayyora_1504@mail.ru*

Almatov Karim Tajibayevich,
doctor, of biological sciences, professor,
National University of Uzbekistan

REGULATION OF THE ENERGETIC FUNCTION AND REACTIVE OXYGEN SPECIES FORMATION IN MITOCHONDRIA BY DAIDZIN

Abstract: In vitro assays, it was found that daidzin does not affect the respiratory function of mitochondria and the rate of Chance's respiratory control, but dose-dependent increases ADP/O ratio. This process is especially noticeable in the oxidation of succinate. Daidzin inhibits the processes of lipid peroxidation and the activity of lytic mitochondrial enzymes. This means that daidzin increasing bilayer areas of mitochondrial membranes, stabilizes the compactness of membranes. In this regard, the availability of exogenous phospholipase A₂ cobra venom to the phospholipids of mitochondrial membranes is difficult.

Keywords: daidzin, liver, mitochondria, glutamate, succinate, ADP/O ratio, cobra venom, phospholipase A₂.

1. Introduction

Daidzin is a main isoflavone isolated from *Pueraria phaseoloides* and is used to neutralize the side effects associated with excessive drinking [1]. In in vitro studies dadzin has proved to be a potent and selective inhibitor of mitochondrial aldehyde dehydrogenase (ALDH-2) [2], which is the main isoform of ALDH catalyzing detoxification of ethanol-dependent acetaldehyde. In recent studies, daidzin inhibited LPS-dependent production of TNF- α in mice [3]. In addition, its antioxidant activity was investigated and established in various studies [4]. According to these studies, it can be assumed that dadzin can have a protective function against the D-GalN / LPS caused hepatic insufficiency.

In one research, it was studied a reducing activity of daidzin on GalN / LPS-induced hepatic failure [5].

The pharmacological action of these biologically active substances is associated with antioxidant, antidipso-tropic and other effects [6]. In one study, it was found that daidzin has a protective effect against carbon tetrachloride, D-GalN – and t-butyl hydroperoxide – caused by hepatotoxicity in vitro [7]. In this study, mice in the D-GalN / LPS-treated group began to die 6 hours later, and the death rate reached 73.3% (11 of 15 mice) after a day. Eight hours after the D-GalN / LPS injection, severe necrosis was observed because of D-GalN / LPS-induced transient (acute) liver failure. It was found that the level of serum aminotransferase significantly increased. The results show that dadzin protects mice from D-GalN / LPS-induced acute hepatic insufficiency, the evidence of which is a marked reduction in mortality and serum aminotransferase in a dose-dependent manner.

Undoubtedly, hepatic histopathology clearly showed that D-GalN/LPS-induced hemorrhage, necrosis and degeneration of hepatocytes, improved dramatically in mice pre-treated with daidzin. Although Hasumuma et al. in the study showed that daidzin does not have a protective effect against D-GalN/LPS-mortality [8].

Daidzin is nuclear receptor that is activated by fatty acids, prostaglandins, and functions as a transcription factor. Daidzin inhibits tumor necrosis factor by regulating positively the prostaglandins [9]. In contrast, the 6- and 8-chlorination of daidzin significantly reduced the agonist effect on prostaglandins [10]. In *in vitro* assays, it was found that the daidzin had the power to block the saturation of tyrosine with iodine [11]. Daidzin react with peroxisomes of proliferative receptors, activated with fatty acids [9].

Mitochondria are organelles, not only providing energy to the organism, but also supporting the dynamic interconnection of metabolism. Mitochondria possess all the basic functions of the cell: contractility, transport of ions, heredity, etc. [12, 13].

The aim of our research was to study the effect of daidzin on respiration and oxidative phosphorylation, the activity of oxidase systems and the formation of reactive oxygen species in liver mitochondria.

2. Materials and methods

The experiments were carried out on Wistar male rats with an initial body weight of 180–200 g. Mitochondria from rat liver cells were isolated according to the method of [14]. All procedures for the isolation of mitochondria were carried out at 0–2 ° C. The energy parameters of isolated mitochondria were studied by B. Chance, G. R. Williams [15].

The experiments were performed with the addition of daidzin into a polarographic cell. The study of the activity of rotenone sensitive and insensitive NADH-oxidase systems, as well as mitochondrial succinate oxidase, was carried out by K. T. Almatov et.al [16]. The process of lipid peroxidation of mitochondria were determined by the method [17]. Calculation of the content of products reacting with thiobarbituric acid was carried out taking into account the molar extinction of malonic dialdehyde equals to $1.56 \times 10^6 \text{ mol cm}^{-1}$ and expressed in nanomol malonaldehyde / min mg protein. Daidzin was used as a glycerin solution and was introduced into a polarographic cell (at a final concentration of 20, 40, 60 μg /

mg of mitochondrial protein) and studied the features of the alteration in the functional state of mitochondria. The mitochondrial protein was determined by Lowry et al. [18]. The results are processed using the Student's t-test and its determination of the arithmetic mean M and its standard error m. Experiments were performed with the addition of daidzin into the polarographic cell. Daidzin was purchased by Shijiazhuang Zulei commerce Co., Ltd. (China).

3. Results and discussion

The data presented in (Table 1) show that daidzin in low concentrations does not affect the rate of glutamate oxidation. However, higher daidzin concentrations slightly decrease the oxidation of glutamate in various metabolic states. In this case, the values of the respiratory control of Chance do not change. With the introduction of daidzin in a dose of 20, 40 and 60 μg /mg protein in a suspension of mitochondria, ADP/O ratio increases by 8.6; 11.5 and 12.3%, respectively, of the control level. This means that daidzin stimulates the exchange of adenine nucleotides ($\text{ATP}^+/\text{ADP}^{3-}$) between the mitochondrial matrix and cytosol, carried out by a special transport system – translocase.

Daidzin does not affect the oxidation of succinate and the rate of the respiratory control of Chance, but the dose-dependent increase in the ADP/O quotient. Daidzin, at a dose of 20, 40 and 60 μg /mg of mitochondrial protein increases the ADP/O quotient by 18.2; 35.1% and 52.7%, respectively, from the control.

In the presence of daidzin, the increase in the ADP/O quotient with succinate in the mitochondria of the liver, in our view, connects with the phenomenon of “reverse electron transfer” (according to the recovery of NAD^+) [19]. A significant advantage of succinate in maintaining a high level of energy-dependent NADH as compared to NAD-dependent substrates as the main factor determining the special role of succinate in energy supply.

In our opinion, an increase in ATP content in mitochondria leads to the closure of the cyclosporin A sensitive pore.

Recently it has been shown that decrease of intracellular content of ATP level by only 15–20%, the intensity of all energy-dependent cell functions falls on 75–80% of the initial value, which leads to the development of multisystem pathologies: violations of the central nervous system, heart function, the synthetic

processes of the liver, kidneys, etc., Ability of the cell to support specific energy-dependent functions (neurotransmitter, receptor, contractile, ion transport and

transmembrane potentials, synthetic processes, etc.) is located in close dependence on the intracellular content of ATP.

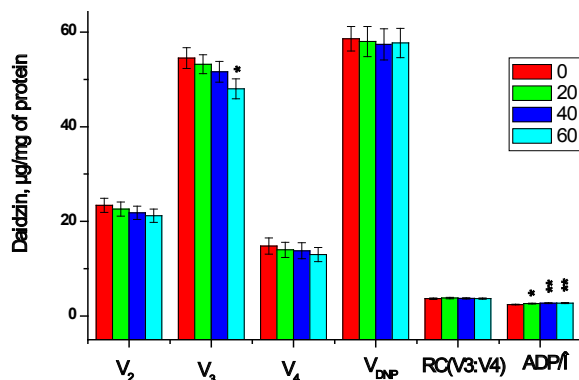

Figure 1. Influence of daidzin on respiration and oxidative phosphorylation in liver mitochondria (glutamate as a substrate)

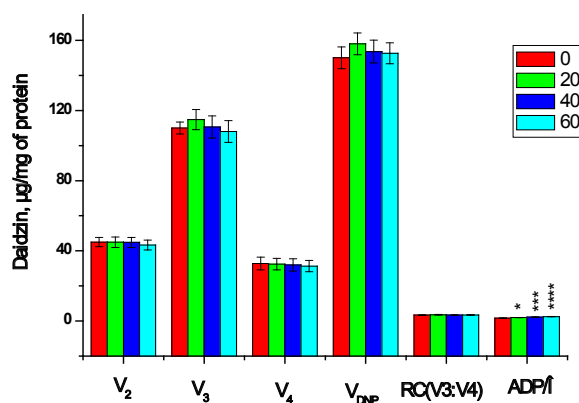

Figure 2. Influence of daidzin on respiration and oxidative phosphorylation in liver mitochondria (succinate as a substrate)

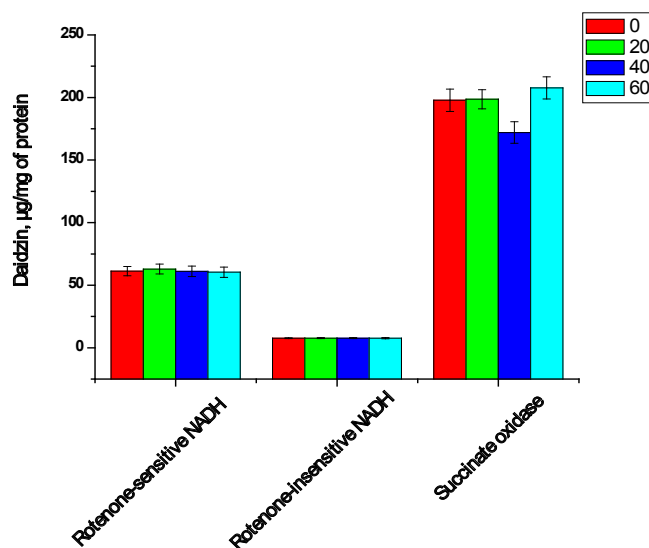

Figure 3. Influence of daidzin on activity of rotenone-sensitive and insensitive oxidases and succinic oxidase in mitochondria

Thus, daidzin does not affect the respiratory function, but it increases the ATP synthesizing function of mitochondria. Synthesis of ATP is particularly noticeable in the succinate pathway of the mitochondrial respiratory chain.

The effect of various biologically active substances on mitochondrial membranes can be determined by changes in the activities of the rotenone-sensitive and insensitive oxidases and succinic oxidase. The physiological significance of these enzymes lies not only in their participation in biotransformation of energy and transport of electrons through the respiratory chain to molecular oxygen, but also in regulating the rate of elimination of the arrival of substances and metabolites, as

well as changes in the conductivity and contractility of mitochondrial membranes [19].

4. Conclusion

To study the effect of daidzin on rotenone-sensitive and insensitive oxidases and succinic oxidase activities, 20, 40 and 60 µg of daidzin were added to each mg of mitochondrial protein into the polarographic cell and the results of the oxidase activity change are shown in Fig. 2. From obtained results it is obvious that daidzin doesn't influence on activity of mitochondrial oxidases. Hence, daidzin enhances the synthesis of ATP without increasing the rate of oxygen and substrate consumption in the mitochondrial respiratory chain. In our opinion, daidzin increases the activity of adenenucleotide transferase.

References:

1. Keung W.M., Lazo O., Kunze L., Valle B. L. Daidzin suppresses ethanol consumption by Syrian golgen hamsters without blocking acetaldehyde metabolism // *ProcNatlAcadSci USA.*– 1995.– V. 92.– P. 8990–8993.
2. Keung W.M., Vallee B. L. Daidzin: a potent, selective inhibitor of human mitochondrial aldehyde dehydrogenase // *ProcNatlAcadSci USA.*– 1993.– V. 90.– P. 1247–1251.
3. Hasumuma R., Kawaguchi K., Kikuchi S., Sugiyama T., Kumazawa Y. Effects of isoflavones and soybeans fermented with *Bacillus subtilis* on lipopolysaccharide-induced production of tumor necrosis factor- α and fibrinolysis in vivo // *Immunopharmacol Immunotoxicol.*– 2007.– V. 29.– P. 323–333.
4. Cherdshewasart W., Sutjit W. Correlation of antioxidant activity and major isoflavonoid contents of the phytoestrogen rich *Pueraria mirifica* and *Pueraria lobata* tubers // *Phytomedicine.*– 2008.– V. 15.– P. 38–43.
5. Prasain J. K., Jones K., Kirk M. et al. Profiling and quantification of isoflavonoides in kudzu dietary supplements by high performance liquid chromatography and electrospray ionization tandem mass spectrometry // *J. Agris Food Chem.*– 2003.– V. 51.– P. 4213–4218.
6. Chueh F. S., Chang C. P., Chio C. C., Lin M. T. Puerarin acts through brain serotonergic mechanisms to induce thermal effects // *J. PharmacolAc.*– 2004.– V. 96.– P. 420–427.
7. Park J. G., Cheon H. J., Kim Y. S., Kabg S. S., Choi J. S., Lee S. M. Hepatoprotective activities of daidzin, daidzein, genistein and puerarin in primary cultured rat hepatocytes // *YakhakHorji.*– 2007.– V. 51.– P. 115–125.
8. Sung-Hwa Kim, Jeong-Haing Heo, Yeong Shik Kim, Sam Sik Kang, Jae Sue Choi, Sun-Mee Lee. Protective Effect of Daidzin against D-Galactosamine and Lipopolysaccharide-Induced Hepatic Failure in Mice // *Phytotherapy Res.* – 2008. DOI: 10.1002/ptr.2710.
9. Chacko B. K., Chandler R. T., Mundhekar A. et al. Revealing anti-inflammatory mechanisms of soy-isoflavones by flow: modulation of leukocyte-endothelial cell interactions // *Am J Physiol* – 2005.– V. 289.– P. H908–H915.
10. Makela S., Poutanen M., Lehtima K. J., Kostian M. L., Santti R., Vihko R. Estrogen-specific 17 beta-hydroxysteroid oxidoreductasetype 1 (E.C. 1.1.1.62) as a possible target for the action of phytoestrogens // *ProcSocExpBiol Med.*– 1995.– V. 208.– P. 51–59.
11. Divi R. L., Chang H. C., Doerge D. R. Anti-thyroid isoflavones from soybean: isolation, characterization, and mechanisms of action // *BiochemPharmacol.*– 1997.– V. 54.– P. 1087–1096.
12. Zorov D. B., Isayev N. K. and others. Mitochondria as a multi-faceted Janus. Review // *Biochemistry.*– Moscow,– 2007.– T. 72. 10.– C. 1371–1384.

13. Lipskaya T. Yu., Voinova V. V. Nucleoside phosphatase of mitochondria: the nature of interaction with the outer mitochondrial membrane and the proportion of activity functionally associated with oxidative phosphorylation // *Biochemistry*.– 2008.– T. 73 (3).– P. 395–407.
14. Schneider W. C., Hogeboom G. N. Cytochemical studies of mammalian tissues the isolation of cell components by differential centrifugation // *Cancer. Res.*– 1951.– V. 19.– P. 1–22.
15. Chance B., Williams G. R. The respiratory chain and oxidative phosphorylation. *Adv. enzymol.*– 1956.– V. 17.– P. 65–134.
16. Almatov K. T., Yusupova U. R., Abdullaev G. R. et. al., Determination of the Respiration and energy formation of an organism.– Tashkent.– 2013.– 103 p (in Uzbek).
17. Vladimirov Yu. A., Archakov A. I. Peroxide oxidation of lipids in biological membranes, – Moscow: Nauka.– 1972.– 214 p.
18. Lowry O. H., Rosebrough N. L. et al. Protein measurement with the folin phenol reagent // *J. Biol. Chem.*,– 1951.– V. 193.– P. 265–275.
19. Almatov K. T. Mechanisms of development of mitochondrial membranes damage and the role of lipolytic system. DSc thesis.– 1990.– 380 p.

Niyazova Oybakhor,
 assistant, Samarkand state university,
 Samarkand, Uzbekistan
 E-mail: zizzat@yandex.ru

THE INFLUENCE OF THE CHEMICAL COMPOSITION OF THE SOIL OF THE ORCHARDS TO THE MACRO FAUNA

Abstract: the influence of the chemical composition of the soil of the orchards to the macro fauna has been studied in Uzbekistan for the first time and its effect to the number and composition of the kinds and ecological complexes has been determined. Especially, among insects and invertebrate animals which have been spreaded in the orchards and beetles belong to rhizophagi; earthworms belong to geobionts; and dry land mollusks belong to hygrophags live there.

Keywords: Soil macro fauna, soil, geobiont, phytophage, hygrophil, intensive gardens, mechanical composition.

Introduction. The soil macro fauna has spreaded widely in the nature and it is of theoretical and practical importance. They can be found in the soil and reproduce it, let various pesticides pass to the lower stratum of the soil. As a result of poisonous chemical substances absorbing by soil, the decreasing of micro and macro organisms which grow in the soil is being observed, and the decreasing of earthworms which restore the soil structure are causing the great decreasing of the humus in the fertile soil, too. The soil fauna has a great importance in gathering organic substances in the soil and improvement of water-air conditions of the soil.

It has been given a great importance to not using poisonous pesticides, ecologic equilibrium and natural fertility of the soil since the independence of our republic.

In some cases, picked up vegetables and fruits caused to poison human organism and resulted various infectious and very dangerous diseases to appear. The role of the soil fauna is incomparable in preventing from such cases. As different insects and earthworms living creatures change the physical and chemical features of the soil. Earthworms can be found in the soil and pass a large amount of soil through their organism at the same time digging the stratum full of holes at the depth of 1,5 meters. The amount of the soil which they pass through the system of their digestive organs averages from 12 tons to 100 tons to a hectare or the soil in 7 mm thickness per year.

The amount of earthworms in the will being processed soil is about 350 kg to a hectare. The soil fauna

helps to improve soil fertility, water and air percolating, to soften the soil taking its lower stratum up, to render harmless various poisonous chemical substances and industrial waste products. Besides that, they give a chance to clarify the soil pollution beforehand. Thanks to the soil organisms' activity, the soil fertility exceeds, natural processes which are necessary for the life of living organisms occur normally. Successive reforms which are being carried out in the agriculture of our country give a chance to grow products, to raise the effectiveness of this field. Intensive technologies which have been used in gardening for recent years brought innovations to the development of this branch.

In Samarkand region 6000 hectare gardens and 105 hectare vineyards have been established with new method to this day. In Samarkand district 1531 hectare, in Jomboy district 1753 hectare intensive gardens have been established. If it was grown 240–260 fruit saplings to a hectare some years ago, 2400–2800 dwarf fruit saplings are grown to a hectare in intensive gardens now. Such kind of fruit gardens have been established in the heights where has the difficulty of watering in the foot of the mountain areas. Learning the soil macro fauna of the intensive gardens is one of today's climax problems, too.

Materials and methods

The soil macro fauna has not been researched on the basis of special plan in these areas. That's why we learned the importance and biologic, ecologic features, members of insect and earth wormkinds, dry land

mollusks which spreaded in the soil of fruit gardens in and around Samarkand city.

We used the methods of M. S. Gilyarov [1], T. S. Perel [2] during the process of learning the soil macro fauna. It was followed the examples from the 0.5m² (50 × 100 cm) and 0.25m² (50 × 50 cm) sized areas at the depth of 0–10 cm, 10–20 cm, 20–30 cm, and 30–40 cm. Besides that, we used bottle traps in our experiments. Among gathered materials insect larvae, earthworms and dry land mollusks were fixated in formalin in the capacity of in 0.4–0.5%. Taken materials were fixated in alcohol in the capacity of 70% and dry cockle-shells were put into different test-tubes. All gathered materials were checked with help of reliable books and specialists in the groups of invertebrate organisms, too, when it was necessary. And insects were inanimated in the ether oil and put into the special collection boxes.

Results and discussion. We have researched the selected soil macro fauna of the intensive gardens in Jomboy and Urgut districts, Yettiuylisoy ravine in Urgut district, the Zarafshan reserve, intensive gardens such as “Qaldirg’och nafis bog’lari” (The swallow fine gardens) in Jomboy district, “Ohalik oltin bog’lari” (Gold-

en gardens in Ohalik) in Samarkand region in spring and autumn since 2004–2016 for our experiments.

It was found out that the amount of humus is comparatively more in clover fields and apple gardens. The main reason is that the root system of these crops is well-grown. After growing these crops, a large amount of organic remains will be gathered. And it will be a reason for a high productivity of humification processes. The lines of these plants will not be processed into or will be processed very little. As a result, the anaerobic process will not break and the process of organic remains turning into humus will increase. The remains of fruit trees, for example, apple plant, are full of hard oxidized substances such as lignin, pectin, cellulose. And it will not let them decompose aerobically completely and the forming of humus substances will increase. And it will be observed the positive influence to the amount of the humus of the clover and fruit trees.

The amount of humus is from 0.9–1.9% in irrigative grassland virgin soil of Samarkand region, the highest point of humus in dark-looked soil is 1.4–2.5% and in dark-looked virgin dry-land soil is 0.6–2.9% and it was given in the descriptive table of Samarkand region by mechanical structure (1st table).

Table 1. — The description of the soil in Samarkand region by mechanical structure (in %)

№	Types of soil	The amount of humus	The amount of nitrogen	Amount of the phosphorus	Amount of the potassium	The amount of CO ₂
1	2	3	4	5	6	7
1.	Irrigative dark-looked virgin soil	1.4–2.5%	0.09–0.1%	0.09–0.11%	1.6–2.7%	9–11%
2.	Dry-land dark-looked virgin soil	0.6–2.9%	0.04–0.12%	–	–	5–10%
3.	Irrigative typical virgin soil	0.8–1.5% 0.4–0.6%	0.04–0.10%	0.16–0.20%	1.6–1.9%	8–9%
4.	Dry-land typical virgin soil	0.7–1.6% 0.6–0.8% 0.2–0.4%	0.07–0.12%	–	–	4–5%
5.	Irrigative grass-land virgin soil	0.6–1.2%	0.04–0.06%	0.17–0.18%	–	6–9%
6.	Dry-land light-looked virgin soil	0.4–1.2%	0.01–0.07%	0.08–0.12%	1.5–0.9%	10–11%
7.	Irrigative grass-land virgin soil	0.8–1.8%	0.06 — .12%	–	–	6–7%

1	2	3	4	5	6	7
8.	Irrigative virgin grassland soil	0.9–1.6%	0.04–0.05%	0.12–0.18%	0.6–0%	6–11%
9.	Irrigative grassland soil	0.7–1.5% 0.9–1.9%	0.05–0.11%	0.12–0.25%	0.5–0.3%	8–10%

It was analyzed in laboratory conditions that the amount in soil samples at the depth of 30 cm taken from Jomboy district Zarafshan reserve on May, 2014 was –1.88–1.92; pH – 6.6–6.9; NO_3 – 56.4–58.4; P_2O_5 – 11.6–12.2; F – 1.6–1.8.

The amount of humus at the depth of 30 cm in November, 2014 was –1.96–1.98. pH – 7.0–7.4; NO_3 – 59.2–60.2; P_2O_5 – 15.6–16.6; F – 2.2–2.6.

The amount of humus at the depth of 30 cm was –1.96–1.98. pH – 7.0–7.4; NO_3 – 59.2–60.2; P_2O_5 – 15.6–16.6; F – 2.2–2.6 according to the soil analysis in May, 2015.

It is clear from the table cited above, the amount of humus in irrigative dark-looking virgin soil was 1.4–2.5%. in dry land light-looking virgin soil was 0.4–1.2%. The highest point of the amount of the humus was 1.96–1.98% in Zarafshan reserve in Jomboy district.

More than 250 samples were taken for the research in all. After the analysis of those materials it was found out that the kinds of earthworms belonging to the family *Lumbricidae*; the kinds of dry-land mollusks belonging to the families as *Ariophantidae*, *Agriolimacidae*, *Parmacellidae*, *Hygromeidae*, the kinds of insects belonging to the family *Scarabaeidae* had been spreaded there. Among these families *Eisenia fetida* (Savigny) Vsevolodova-Perel; *Dendrobaena byblica* (Rosa) Vsevolodova-Perel; *Dendrobaena veneta* (Rosa) Vsevolodova-Perel; *Aporrectodea caliginosa* (Savigny) Vsevolodova-Perel; *Aporrectodea rosea* (Savigny) Vsevolodova-Perel – belonging to the family *Lumbricidae*; *Macrochlamys sogdiana* (Martens) – belonging to the family *Ariophantidae*; *Deroceras caucasicum* (L. Pfeiffer) – belonging to the family *Agriolimacidae*; *Candaharia* (L.) *levanderi* (Simroth) – belonging to the family *Parmacellidae*; *Xeropicta candaharica* (L. Pfeiffer), *Leucozonella* (L.) *rufispira* (Martens), *Leucozonella* (L.)

retteri (Rosen) – belonging to the family *Hygromiidae*; *Melolontha hippocastani* F., *Melolontha afficta* Ball, *Amphimallon solstitialis* L., *Oryctes nasicornis*, *Cetonia aurata* L. [3] – belonging to the family *Scarabaeidae* [4] are considered as the high-spreaded types of soil macro fauna. The larva of *Melolontha hippocastani* F. grows in the soil for 3–4 years and feed with the root of plants [5]. More larvae of May beetle can be found in the nut gardens, but less in vineyards and apple gardens. Because in biocenosis ecologic condition is good for these invertebrate animals and there are a lot of biotops, too. And earthworms can be seen much in processed areas.

Fruit trees are planted very close to each other in intensive fruit gardens, their root systems are on the soil and for that reason, insect kinds which were spreaded in the soil live especially in the stratum at the depth of 0–10 cm. And we clarified that the June cockchafer can be found in “Okhalik oltin bog’lari” in Samarkand district and the May cockchafer – in intensive gardens such as “Qaldirg’och nafis bog’lari” in Jomboy district. There were taken mechanical fighting measures against beetles in these gardens and it was settled down the danger of beetles.

Conclusions. 1. As a result of researching the soil macro faunas of fruit gardens (cited Samarkand region as an example) it was clarified that 28 kinds belonging to 8 families, 3 small families, 23 clans and 4 small clans live in this area among high-spreaded insect kinds in all. Among them 9 kinds of dry land mollusks consist of 6 families, 7 clans and 4 small clans; 5 kinds of earthworms – 1 family and 3 clans and 14 insects – 1 family and 10 clans.

2. As a result of researching the ecology of soil macro fauna in fruit gardens it was clarified that the larvae of insect families belong to rhizophagi; beetles belong to phytophage; earthworms – gabions; and dry land mollusks – hygrophils.

References:

1. Gilyarov M. S. Features of soil as habitat and its importance in the evolution of insects. Leningrad: Science, – 194. – 280 p.
2. Perel T. S. Distribution and patterns of distribution of earthworms of USSR fauna. – M.: Science, – 1979. – 270 p.

3. Krijanovskiy O. L. Composition and origin of terrestrial fauna. – M. – L.: Science, – 1965. – 419 p.
4. Likharev I. M., Viktor A. Y. Slug fauna of the USSR and neighboring countries. (Gastropoda Terrestria Nuda) // USSR Fauna. Mollusks. – T. 3. – M. – L., – 1980. – Pub. 5. – No. 122. – 437 p.
5. Mavlonov O. M., Ahmedov G. KH. The soil zoology. – T., – 1992. – 80 p.
6. Shileyko A. A. Land mollusks contracting the fauna of the USSR of Pupillina (Gastropoda, Pulmonata, Geohpila) // USSR Fauna. Mollusks. – L., – 1984. – T. 3. – Pub. 3. – No. 130. – 399 p.
7. Prizemin A. A., Kachkaryov V. R. Details of macro fauna of the soil cover in the steep-forest zone of the Orlovskaya districts // Vestnik ORYOL GAU No. 3, 31(13). – P. 48–53.
8. URL: <http://www.krugosvet.ru/enc/nauka>
9. URL: http://tehnika/biologiya/pochvennaya_fauna.html
10. URL: <http://elibrary.ru/item/asp?id=20799821>
11. URL: <https://ru.wikipedia.org/wiki>

*Rzaev Rakhat Muratbaevich,
Karakalpak State University,
Nukus, Republic of Uzbekistan
E-mail: svetmamb@mail.ru*

THE STUDY OF HEART RATE CHARACTERISTICS IN THE POPULATION IN THE CONDITIONS OF KARAKALPAKSTAN

Abstract: This article deals with the age-specific peculiarities of heart [cardiac] rate of youth, living in the Republic of Karakalpakstan. Studying the mechanism of regulation and functional interaction between regulatory circuit are the most actual direction fundamental and applied physiology. In fact that, the youth of the first age-specific group the rate of functioning basic system is in the limit of measurement.

Keywords: Karakalpakstan, age-specific peculiarities, regulatory circuit, environment.

One of the most important tasks of modern physiology is the study of the mechanisms of adaptation of the organism to various types of activity [1, 2]. Cardiorespiratory system that provides oxygen to the cells of the body is one of the most important physiological systems that determines both mental and physical performance of children in ontogeny and adaptation to learning activity [3, 6]. The required levels of minute volume of respiration can be provided only in the presence of an appropriate functional reserve and the maturity of the mechanisms of regulation of respiration, which ensures the economization of the functioning of the respiratory system.

Scientific problems of assessing the impact of environmental factors on human health and the rationale for the system of recreational activities are today the priority tasks of state environmental policy in virtually all developed countries. The establishment of cause-effect relationships between environmental risk factors and the health status of the population makes it possible to manage risk factors for preventive purposes. Assessment of the health of the population, the study of its essence, the accumulation of necessary scientific information has become an urgent problem, which has a high public and state significance.

The influence of the environment is reflected in the functional state of the human body [1]. The circulatory system is particularly sensitive to the influence of the external environment, comparatively early on in adaptation reactions [2, 4] and can be considered as a sensitive indicator of adaptive reactions of the whole organism [1].

The study of the mechanisms of regulation and functional interactions between regulatory contours is one of the most relevant areas of fundamental and applied physiology and medicine. The analysis of heart rate regulation will make it possible to obtain prognostic information about the functional state (FS) and the features of adaptive reactions of the whole organism [4, 5].

We examined 126 practically healthy young men aged 18–22 years, living in different regions of the Republic of Karakalpakstan. Ecophysiological monitoring was carried out from 2015 to 2017. The group of students included students studying at the Karakalpak State University.

To estimate the sequence of sinus cardiac contractions, the following indices were calculated: mean duration of R-R intervals and standard deviation of R-R intervals (SDNN)) is a statistical indicator characterizing HRV as a whole. We calculated heart rate (HR), stress index (SI), activity index of regulatory systems (PARS), systolic (SBP) and diastolic blood pressure (DBP), double Robinson (DP) product.

In the course of our studies, we found that in young men (20–22 years) SBP is higher than in young men of the first group (18–19 years) (138.7 ± 10.1 vs. 120.1 ± 7.8 mm Hg., $p < 0.05$). According to the DBP indices, there were no distinct differences between the students of both groups (84.5 ± 6.3 and 80.8 ± 5.8 mm Hg, respectively, $p > 0.05$). In our opinion, the consequence of a high level of SBP in the second group is large values of DP (44.2 ± 8.1 versus 40.9 ± 3.4 mmHg, $p < 0.05$). In our

opinion, higher values of blood pressure in the second group, in comparison with the young men of the first group, apparently can also be a consequence of increased total peripheral resistance of the vessels.

The heart rate in the boys of the second group is lower (76.5 ± 8.8 beats/min and 3622 ± 639 ml/min) ($p < 0.05$) than in younger men (20–39 years) Karakalpakstan (82.6 ± 7.6 bpm and 4341 ± 515 ml/min).

To maintain this level of functioning of the main body systems, the values of the integral indicator of the activity of regulatory systems (PARS = 3–4 points) in young men (20–22 years) indicate a state of moderate stress of regulatory systems. It is also established that in young men of the first age group, the level of functioning of the main systems is within the limits of the standard.

When determining the type of autonomic regulation in older boys (the second group), the prevalence of the number of vagotonics (66%) was noted, in young men (the first group) – the number of normotonics (62%).

According to experts, seasons of the year are an important factor in the formation of a person's functional state [5, 7]. Throughout the year the person undergoes natural seasonal acclimatization cycles.

The functional state of the circulatory and respiratory systems of a person depends on the phase of the annual cycles of natural seasonal acclimatization and tempera-

ture conditions of the environment. Up to now, there is no complete information on the annual dynamics of functional rearrangements in the body and its effect on human ontogeny in conditions of aridization and desertification of the Southern Aral Sea region, although this has great scientific and practical significance.

It has been established that among the students living in the Republic of Karakalpakstan in the regulation of the heart rate in younger boys (the second group) during the annual cycle of observation, the influence of the central contour over the autonomous contour predominates. The most pronounced centralization of cardiac rhythm management was recorded in June – July and December. In the second group of boys in the cold season, differences in the functional state of the cardiovascular system and vegetative regulation were revealed, while in the summer period these differences were not noted.

It was also noted that the students under examination have optimal regulation of heart rate and tension of regulatory systems. It was revealed that the participation of the central contour of regulation is minimal, and the sympathetic balance is somewhat shifted towards the parasympathetic link of the VNS. At the same time, it has been established that stabilization of compensatory-adaptive mechanisms occurs in September-October.

References:

1. Aghajanyan N. A., Baevsky P. M., Berseneva A. P. Assessment of adaptive capabilities of the body and the risk of disease development // – M. – RUDN. – 2006. – 284 p.
2. Dratsev E. Yu., Vikulov A. D., Melnikov A. A., Alekhin V. V. Vegetative management of the heart rhythm and regional vascular reactions // Physiology of man. – 2008. – T. 34. – No. 2. – P. 44–50.
3. Kipshidze N. N. The prevalence of cardiovascular diseases, their endogenous risk factors among the population of older age // Risk factors and longevity. – Tbilisi. – 1985. – P. 5–20.
4. Konev Yu. V. Age changes in the cardiovascular system // Med. Vesti. – 2004. – No. 4 (275). – 8 p.
5. Ribera Kasada J. M. Aging and cardiovascular system // Clinical gerontology. – 2000. – No. 11–12. – P. 28–36.
6. Shabalin A. V. Functional parameters of the cardiovascular system in elderly people of the West Siberian region // Clinical gerontology. – 2001. – No. 9. – P. 18–21.
7. Fried L. P., Kronmal R. A., Newman A. B. Risk factors for 5-year mortality in the elderly: the Cardiovascular Health Study. *Jama*. – 1999. – Vol. 279. – P. 585–592.

Ryabceva Yulia Sergeevna,
 doctor, of Philosophy (Ph. D),
 Head of the Scientific-Research Laboratory
 "Live Country", Agri Research Foundation
 E-mail: yr@futura.com.ua

THE EFFICIENCY OF *BOMBUS TERRESTRIS* (INSECTA: APIDAE) AS POLLINATORS OF SWEET CHERRIES IN UKRAINE

Abstract: The efficiency of *Bombus terrestris* colonies pollinating the sweet cherry orchards was studied in two locations of Ukraine: Novoselki village, Kyiv region (Institute of Horticulture, National Academy of Agrarian Sciences of Ukraine), and Sadove village, Zaporizhia region (Producing and commercial company "Melitopol cherry" Ltd). In the study of the bumblebee flying activity, it was established that the insects remained active during the whole day in spring, if the temperature was stable. Our observations confirm that the bumblebees successfully pollinate the plants in the overcast weather, starting at the temperature threshold of 8 °C, which is especially important for pollination of the outdoor crops.

Bumblebee colonies provided a significant increase in the yield of sweet cherry by 29.93% (Sadove village), and by 503% (Novoselki village). This incredible increase in the latter yield is caused by the timely and high-quality pollination of flowers by bumblebees, counteracting to a degree the unfavorable spring weather conditions of 2017 in Kyiv region.

Keywords: pollination, bumblebees, *Bombus terrestris*, sweet cherry, *Prunus avium*, yield.

Introduction

A high-quality harvest is inconceivable without the participation of pollinator insects. It is through their efforts that the pollen of one plant falls on the flower of another plant of the same species, i.e. there is cross-pollination. This type of pollination contributes to the development of faster-ripening, symmetrical and large fruits.

Natural pollination is provided by many insects: bees, bumblebees, flies, butterflies and various species of beetles, etc. The leader of all pollinators is the honey bee, which does up to 80% of the total crop pollination [6, 15]. However, in the last few decades, honey bees have been scarce or completely absent, causing a significant decrease in the yield of several important horticultural plants, including fruit trees.

There is no horticultural technique to compensate for the absence of natural pollination, which is why finding the alternative pollinators and studying their effectiveness are such important tasks.

More than 30 years ago, the first bumblebee colonies were grown on an industrial scale for the pollination of

greenhouse tomatoes [12]. The demand for efficient pollinators contributed to the rapid growth in bumblebee colonies sales and their active use for pollination of indoor and outdoor crops [9, 11, 13, 14, 16].

Nowadays, the peculiarities of using bumblebee colonies for pollination of fruit crops remain an urgent problem. There are recent studies that describe the positive influence of the bumblebee pollination on the harvest of cherries, apricots, pears, apple trees, etc. [7, 8, 10]. However, they present fragmented data and require clarifications and additions.

Studying the use of bumblebee colonies for pollination of fruit trees will possibly allow organizing an effective pollination process of these crops and increasing their yield.

The main goal of our study was to evaluate the pollination activity of *Bombus terrestris* (Linnaeus, 1758) on sweet cherry *Prunus avium*.

The following **tasks** were then set:

1. Assessing the attendance of cherries by commercial bumblebee colonies "Live Country";

2. Measuring the basic yield indicators in the areas serviced by commercial bumblebee colonies and in control areas with a natural composition of pollinators.

Materials and methods

Study of the bumblebee pollinating effectiveness on the cherry cultivar "Melitopolska Chorna".

The research was performed in spring of 2017, at the plantations of Producing and commercial company "Melitopol cherry" Ltd (Sadove village, Zaporizhia region, Ukraine).

Climate. The experiment was conducted in an area with a sharply continental and arid climate. Annual precipitation fluctuates from 370 to 430 mm.

Plant sort description

The tree is big, fast-growing. The tree habit is wide and round, raised, dense. The bark on stem and skeletal branches are gray-brown. Shoot-forming ability is strong. Shoots are straight, yellowish-greenish-gray. The buds are large, oval, 7 mm long. The foliage is quite dense.

The fruits are large, monocarpous, 6–8 g in average, rounded oval, dark red (almost black). Fruit apex is rounded, the fruit base with a shallow and wide depression. Seam is shallow and hardly noticeable. Stem is 45–49 mm, of moderate thickness, easily picked off the branch. Pitting the fruit is easy, the pulp tears off without juice loss. Skin is thin, dense, dark red, and at full maturity almost black, shining, easily separated from the

pulp. Pulp is dark red, dense, fleshy and juicy. Juice is dark red. Pit is small and rounded and. The taste is sweet and pleasantly acidic. The cultivar is self-sterile.

Six commercial bumblebee colonies ("Live Country", Ukraine) were placed at an experimental plot (0.5 ha). The orchard was planted in 2013 with "Melitopolska chorna" sweet cherry, at a planting distance of 5 x 3 m. A similar plot, without bumblebees, was used as control (Fig. 2). The distance between these plots was 150 m.

The bumblebee hives were set up in the Institute of Horticulture on April 13, 2017, when sweet cherry began to blossom.

The flying activity of bumblebees was estimated once a week for 3 weeks. Activity was defined as a mean number of bees leaving hives and returning to the nest – in the morning, at the midday and in the evening for 15 minute periods.

Two 50m*25m sites were chosen at the experimental and control plots to study the pollinating efficacy of bumblebees (Fig. 2). Each site harbored 40 cherry trees, and for each tree the number of fruits, the number of deformed fruits and the total yield weight were calculated.

Evaluating the pollinating efficacy of bumblebee colonies on the sweet cherry cultivar "Lubava".

The experiment was conducted in spring 2017 at the Institute of Horticulture, NAAS of Ukraine (Novoselki village, Kyiv region, Ukraine).

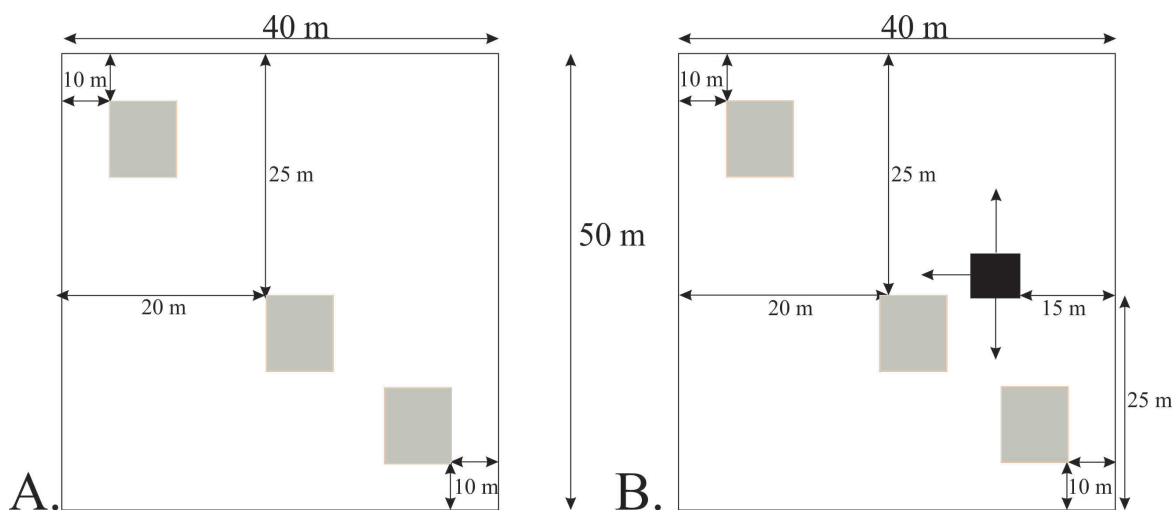

■ – bumblebee hives set up; direction of the flight openings;

■ – sites for assessment of bumblebee pollinating efficacy

Figure 1. Design of the experiment on "Lubava" sweet cherry cultivar: A – control area; B – experimental area

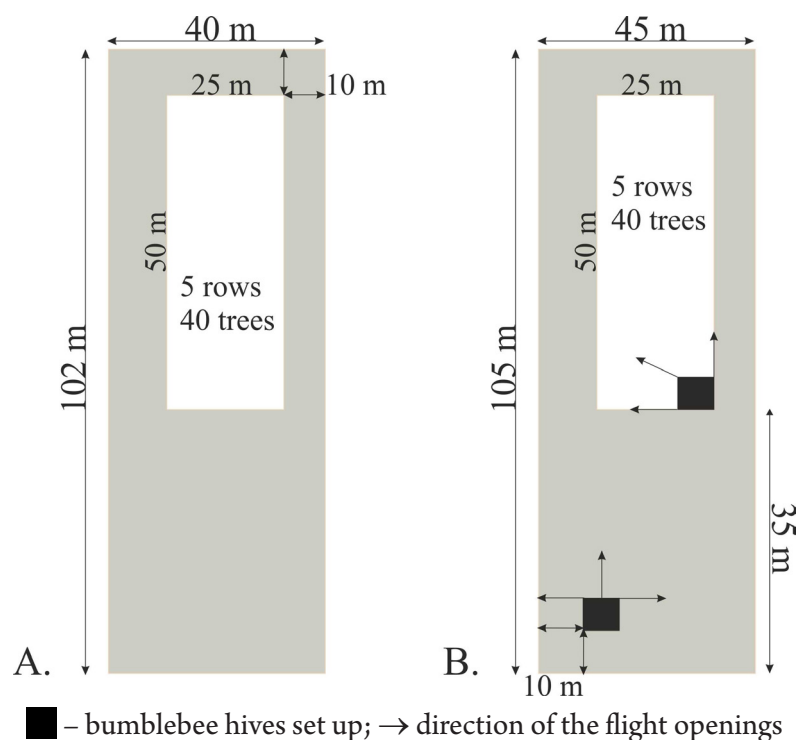

Figure 2. Design of the experiment on “Melitopolska Chorna” sweet cherry sort: A – control area; B – experimental area

Climate. The study area is characterized by moderate continental climate, with approx. 550 mm average annual precipitation.

Plant cultivar description

The tree is of medium height, with a dense, rounded and well-branched habit. Fruits are produced during the 4th-5th year after planting. The tree is not self-fertile. The fruits are large (8–9.8 g), rounded heart-shaped, yellow with bright red blush, tolerant to cracking.

They are easily detached from stem. The pit is of moderate size, easily detached from flesh. Pit to flesh mass ratio is 4.9%. The flesh is light-yellow, juicy, crunchy, with a nice sweet flavor. The produced yield is suitable for all purposes.

We used three commercially sourced colonies of *B. terrestris* (“Live Country”, Ukraine) that were placed at the experimental plot (0.2 ha). The trees were planted in 1997, at the planting distance of 6 m*4 m.

The bumblebee hives were set up at the beginning of inflorescence period, on April 13, 2017. The bumblebee hive set up scheme is given in Fig. 1.

As control plot, 0.2 ha area with sweet cherry cultivar “Lubava” was selected, planted in 1997, with planting distance of 6m * 4m. The distance between these plots was 500 m.

The state of bumblebee colonies was monitored for the first few weeks after their installation. In addition to the external inspection of hives, the number of foragers flying out of the nest in 15 minutes was counted.

To assess the bumblebee pollinating efficacy, three sites were selected at the experimental plot (fig. 1). The ovary percentage, the percentage of crop damage from unfavorable weather conditions, and the ratio of crop to plant weight were determined for each site. These characteristics were also assessed at the control plot.

All obtained quantitative data was processed using the standard “PASW Statistics 17” and “Statistica 6.0” software packages.

Results and discussion

Today, bumblebees are recognized among the most effective pollinators in agriculture. About 30 years ago, it was shown that bumblebees can excellently pollinate tomatoes in greenhouses. Since then, bumblebee colonies have been successfully used not only for pollination of indoor crops, but also for raspberries, strawberries, blueberries, pears and other important outdoor plants. This increased involvement of bumblebees to a greater extent, thanks to their advantages over other insect pollinators including honey bees. Honey bees can also

pollinate most of agricultural crops, but they are often less efficient than bumblebees.

1) Bodies of bumblebees are built to carry twice as much pollen as honey bees.

2) Bumblebees provide good cross-pollination because of their unique flight process which involves frequent change of plants and tree rows.

3) Bumblebees have longer tongues than honey bees, which are unable to pollinate certain flowers because of it.

4) Bumblebees are more tolerant to unfavorable weather than other pollinator insects. They can pollinate in overcast weather and at 8–10 °C, which is especially important in the case of outdoor crops.

For pollination of outdoor fruits and berries, it is recommended to use a colony with one queen, 120–150 workers, and brood (larvae, eggs, and pupae). Higher numbers of larvae require more pollen brought by the workers in the nest. They forage more and, consequently, increase the productivity of pollination. Bumblebee pollination leads to higher fruit quality and increased total yield, and thus to a better price.

The results of experiment on the cultivar "Melitopolska Chorna".

Table 1. – Flying activity of commercial bumblebee colonies "Live Country" on the sweet cherry cultivar "Melitopolska Chorna"

Day of observation	Time of observation	Weather	Insects departed	Insects returned
25.04.2017	8.00	Sunny, + 10 ° C	53	48
	11.00	Strong wind, + 12 ° C	14	17
	16.00	Strong wind, + 8 ° C	3	4
02.05.2017	8.00	Cold, +4 ° C	0	0
	11.00	Windy, + 9 ° C	0	0
	16.00	Strong wind, + 7 ° C	0	0
09.05.2017	8.00	Sunny, + 17 ° C	43	56
	11.00	Sunny, + 22 ° C	69	49
	16.00	Light breeze, + 18 ° C	42	51

In the first week of observations (25.04), the maximum activity of bumblebees was recorded in the morning at sunny weather: 53 foragers flew out of the nest, 48 bumble bees returned to the hive during the 15 minute observation.

In the afternoon the temperature dropped. This appeared to be the decisive factor, which caused the flying activity of bumblebees to decrease to three departures.

In early May, cold and windy weather fully prevented the flight activity. However, in sunny weather and at +17 °C,

In our study, the foraging insects could move in and out of the colony freely and follow their normal daily routine. The flying activity of bumblebees was estimated in cherry blossom period. To this end, the bumblebees' departures and arrivals were counted in the morning, at midday and in the evening for 15-minute periods (Table 1).

The insect is always influenced by a combination of factors. However, the factor that is most remote from its optimal level affects it most strongly [5].

The daily activity of bumblebees in nature was studied separately by D. V. Panfilov [2] and by V. I. Blinnikov [1] (on *Carduus pycnocephalus* L. in August). Researchers found that the insect forage all day long, with markedly higher intensity in the late morning (9–11 a.m.) and in the evening (4–6 p.m.). From noon to 2 p.m., most foragers are in the nest avoiding the danger of overheating in this most hot time of the day. According to the classification of rhythms by V. B. Chernyshev [3], the bumblebees can be classified as daytime insects with a long morning and evening activity.

the flight activity index increased to 43 flights in 15 minutes. At 11 a.m., the maximum number of departures in 15 minutes was 69. By 16 p.m., the insect activity declined to 42 flights.

According to the observations, the bumblebee flight activity is constant in the morning and at noon if the air temperature is moderate. If the temperature drops to + 4... + 7 °C, the bumbles do not fly out to forage. Nevertheless, at the threshold of + 8 °C (first week) they resume pollinating. Our results confirm that bumblebees

can pollinate in the overcast weather and at + 8 ... 10 ° C, which is most important for outdoor growers.

The results of *B. terrestris* bumblebees pollinating the sweet cherry cultivar “Melitopolska Chorna” are given in (Table 2).

Table 2. – Pollinating efficiency of bumblebee colonies “Live Country” on the sweet cherry cultivar “Melitopolska Chorna”

Yield indicators	Experimental plot	Control plot	Difference
Number of fruits per tree	482.0	369.8	+30.33%*
Yield weight per tree, kg	38.63	29.72	+29.93%*
Percentage of deformed fruits per tree	0.69%	0.89%	+0.2%**

Note: * $p < 0.01$; ** $p > 0.05$ (difference is not significant)

Bumblebee pollination caused the number of fruits to grow by 30.33% ($t = 2.98$, $df = 78$, $p < 0.01$), to 482 fruits per tree compared to 369.8 fruits on the control plot.

The number of flowers, as a rule, much exceeds the number of ripe fruits for almost all cultivars of sweet cherry. Excess flowers and ovaries fall in the first weeks after flowering, mainly because of insufficient pollination and fertilization, and delayed development [4].

Thus, at the plot with the natural composition of pollinators, approximately 30.33% of flowers were either less or not at all pollinated compared to flowers on the plot, where commercial bumblebee colonies were active.

The percentage of deformed fruits at the experimental plot was lower by 0.2% than at the control plot.

However, this difference was statistically insignificant ($t = 1.51$, $df = 78$, $p > 0.05$).

As a result of bumblebee activity, the yield weight significantly increased by 29.93% ($t = 2.96$, $df = 8$, $p < 0.01$). The bumblebee colonies increased the overall pollination of the studied sweet cherries, thus causing the larger yield weight.

The results of experiments on the “Lubava” sweet cherry cultivar.

The bumblebee colonies were observed successfully foraging in cold weather (+ 5 ... +9 ° C) (Fig. 3). In this temperature range and in sunny weather, bumblebees much more often (up to 57 times) flew out after noon, closer to 15.15 p.m. (21.04).

The daily dynamics of bumblebee activity is most likely explained by the combined effect of considered factors.

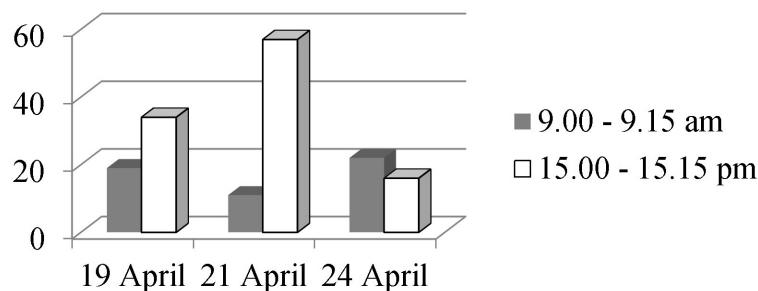

Figure 3. Flying activity of commercial bumblebee colonies “Live Country” on the sweet cherry cultivar “Lubava”

Table 3. – Pollinating efficiency of *Bombus terrestris* on the sweet cherry cultivar “Lubava”

	Experimental plot	Control plot	The effect of bumblebee activity
Percentage of damage caused by unfavorable weather conditions,%	2.03	39.5	-37.47*
Set fruits,%	38.2	38.5	-0.3%***
Total yield per tree, kg	9.2	1.83	+503%**

Note: * significance level of 5% ($p < 0.05$); ** significance level of 1% ($p < 0.01$); *** not significant ($p > 0.05$)

At + 5 ... + 9 ° C, the foragers were relatively active all day long, making from 11 to 57 flights in 15 minutes.

The pollinating efficiency of *B. terrestris* is presented in (Table 3).

The -2 ° C ... -5 ° C frosts in April and May present the biggest danger for the sweet cherry yield. These frosts damage the reproductive buds and ovaries significantly, sometimes even killing them. The pistil stigmas are the most sensitive flower parts that can die in the buds or after the flowers start blooming.

In the study, frosts of low intensity (0 ... -2 ° C) were noted in the Kyiv region when the sweet cherries were blooming. The yield loss caused by unfavorable weather was significantly higher by 37.47% ($t = 2.8$, $df = 4$, $p < 0.05$) on the plot with the natural pollinator combination, in comparison with the plot with bumblebee activity. It is obvious that the bumblebee colonies lessened the influence of spring frosts. If the pollination and germination of the pollen tube happened before the pistils have frozen off (at -1.5 ° C), the fruits would develop as usual. The bumblebees contributed to the timely and qualitative pollination and thus to a significant reduction in yield losses from unfavorable weather factors. Thus, the yield weight increased by 503% ($t_c = 16.01$, $df = 4$, $p < 0.01$).

Conclusions

It is reliably shown that the bumblebees enhance the quantitative indicators of the sweet cherry yield. It is found that at a relatively stable temperature in spring, the foragers remain highly active. Our observations confirm that bumblebees can effectively pollinate plants in overcast weather, at a temperature of +8 ° C, which is especially important for pollination of outdoor crops.

On the example of two sweet cherry cultivars, we showed the efficiency of using bumblebee colonies for pollination of this species. Bumblebees provided the high-quality pollination, contributing to an increase in the number of fruits per tree (Sadove village, Zaporizhia region), and weakened the influence of negative weather conditions on the harvest (Novoselki village, Kyiv region).

Thus, we believe that the bumblebee colonies are promising for obtaining high yields of sweet cherry.

Acknowledgements

The authors are grateful to O. N. Yareschenko and E. A. Kyschak (Institute of Horticulture, National Academy of Agrarian Sciences of Ukraine), and M. I. Grintsev (Producing and commercial company "Melitopol cherry" Ltd) for their helpful assistance in the course of this work.

The work was supported by "Futura" Foundation for culture and innovation.

References:

1. Блинников В. И. Зоология с основами экологии. – М.: «Просвещение». – 1990. – С. 68–80.
2. Панфилов Д. В. К экологической характеристике шмелей в условиях Московской области // Учен. Зап. Пед. Ин-та им. Потемкина. – 1956. – № Т. 61. – Вып. 45. – С. 467–483.
3. Чернышев В. Б. Экология насекомых. – М.: Изд-во МГУ, – 1996. – 304 с.
4. Шайкин В. Г. Энциклопедия сада. – М.: Олма-Пресс, – 2002. – 351 с.
5. Яхонтов В. В. Экология насекомых. – М.: Высшая школа, – 1964. – 460 с.
6. Bohart G. E. Insect pollination of forage crops // Adv Agron. – 1960. – V. 12. – P. 72–58.
7. Calzoni G. L., Speranza A. Pear and plum pollination: honey bees, bumble bees or both? // Acta Hort. – 1996. – V. 423. – P. 83–90.
8. Chaillout S. Do commercial bumblebees (*Bombus terrestris*) have an added value in outdoor pollination of sweet cherry (*Prunus avium*) and raspberry (*Rubus ideaeus*)? – Agricultural sciences. – 2016. – 49 p.
9. Goodell K., Thomson J. D. Comparisons of pollen removal and deposition by honey bees and bumblebees visiting apple // Acta Hort. – 1997. – V. 437. – P. 103–107.
10. Velthuis H. H. W., van Doorn A. A century of advances in bumblebee domestication and the economic and environmental aspects of its commercialization for pollination // Apidologie, Springer Verlag. – 2004. – V. 37 (4). – P. 421–451.

11. Javorek S. K., MacKenzie K. E., Vander Kloet S. P. Comparative pollination effectiveness among bees (Hymenoptera: Apoidea) on lowbush blueberry (Ericaceae: *Vaccinium angustifolium*) // Ann. Entomol. Soc. Am.– 2002.– V. 95.– P. 345–351.
12. Ravestijn W. van, Nederpel L. Trostrillers in België aan de kant: hommels doen het werk // Groenten en Fruit.– 1988.– № 6 (12 februari).– P. 38–41.
13. Sampson B. J., Spiers J. M. Evaluating bumblebees as pollinators of ‘Misty’ southern highbush blueberry growing inside plastic tunnels // Acta Hortic.– 2002.– V. 574.– P. 53–61.
14. Thomson J. D., Goodell K. Pollen removal and deposition by honeybee and bumblebee visitors to apple and almond flowers // J. Appl. Ecol.– 2001.– V. 38.– P. 1032–1044.
15. Todd F. E., McGregor S. E. The use of honey bees in the production of crops // Ann Rev Ent.– 1960.– V. 5.– P. 265–278.
16. Whidden T. L. The fidelity of commercially reared colonies of *Bombus impatiens* Cresson (Hymenoptera: Apidae) to lowbush blueberry in Southern New Brunswick // Can. Entomol.– 1996.– V. 128 (5).– P. 957–958.

*Seytkamalov Khayratdin Maulenovich,
Nukus branch of the Tashkent
University of information technologies,
Uzbekistan, Karakalpakstan
E-mail: svetmamb@mail.ru*

COMPARATIVE ANALYSIS OF CARDIAC ACTIVITY OF CATTLE IN THE CONDITIONS OF SOUTHERN ARAL SEA AREA

Abstract: To the article the results of comparative analysis of electrocardiogram are driven for the cows of different breeds in Republic of Karakalpakstan. It is set that the high temperature of environment and sunny insolation render negative influence on the functional parameters of the cardiac vascular system of animals.

Keywords: Aral sea area, ecosystem transformations, salt aerosol, degradation, mathematical modeling.

Lately development of stock-raising on industrial basis requires creation of optimal terms for animals taking into account physiological norms and perfection of the system of zoology-veterinary service. The functional state of the cardiovascular system of animals is one of basic physiological indexes, on that it is possible to judge about character influences of environment on an organism.

Character of electrocardiography curve is determined not only by age of animal, influence of *стельности*, lactations, but to the considerable measure by influence of environment, temperature, humidity, air, to day's seasonal recurrence of meteorological factors by the terms of maintenance and feeding [1].

For finding out of features of the functional state of *телят* from birth and during the first six months of life, it is necessary to study the dynamics of functional activity of heart and basic vegetative functions in age-related aspects, and also to educe the age-related and pedigree changes in adjusting of these functions in the conditions of Republic of Karakalpakstan. Necessity of study of features of physiological adaptation of cows, *телят* and other animals to the new terms of maintenance and feeding, influences of high temperature and solar radiation of pain irritants and stress-factor on an organism is one of issues of the day of modern physiological science [2, 3].

An aim of this research is a ECG- analysis of cardiac activity of cattle in the conditions of Southern Aral sea area.

Research was conducted on the cows of different breeds (blackly-pied, by a borax Latvian, zebytypes) on

territory of Kanlikul and Nukus of districts of Republic of Karakalpakstan. Made age of experimental cows 5–6. Living mass for the cows of blackly-steppe breed – 470–580 kg, brown Latvian breed 454–470 kg, zebytypes breeds are 425–435 kg.

The estimation of cardiac activity was conducted on the basis of electrocardiography (ECG) research of animals. Registered oneself ECG in frontal and *сагиттальных* projections on the method of Roshevsky (1958, 1960) and Mezenceva [4]. A heart rate, duration of intervals of ECG, coefficient of arrhythmia, data of axonometry, was taken into account. Material treated statistical methods Merkureva [4].

Results and discussion

Result of anthropogenic influence, stipulating reductions of aquatorium of the Aral Sea area, strengthening of processes of aridization ecosystems of region, grows short to the area of productive vegetable associations, what natural potential of pastures goes down because of, that negatively on development of stock-raising. An ecological situation in a region requires an all-round study and development of scientifically-reasonable suggestions, on protecting of animals from influence of high temperature and solar radiation, what cannot be carried out without the study of mechanisms of adaptation.

For the increase of the productivity of cattle research of physiological mechanisms of adaptation of *привозных* pedigree animals is needed to the extreme terms of Republic of Karakalpakstan. Researches of

electrocardiogram for cows conducted at influence of different on intensity and durations temperatures of air (18–43 ° C) and solar radiation from 2065–3396 кДж. 18–20 ° C accepted for an initial ambient temperature (optimal).

Results undertaken studies showed the specific feature of adaptive reaction of the cardiovascular system on a temperature factor for the cows of different breeds. Experimental data show that at the temperature of air of 18–20 ° C at a zebytypes cattle frequency of heart-throbs was 57.69 ± 2.32 oud/min, at a blackly-pied breed – 61.78 ± 2.14 oud/min, and at the brown Latvian breed 59.94 ± 2.27 oud/min. At the increase of temperature of air to 36–40 ° C this index for the cows of blackly-pied breed rose on 14.3%, for the cows of the brown Latvian breed on 11.4% ($p < 0.05$). At the further increase of temperature of air to 41–43 ° C at the blackly-pied breed of frequency of heart-throbs rose on 12.6%, at the brown Latvian breed accordingly on 16.4% ($p < 0.05$).

Conducted analysis of duration of cycle of R – R showed that at an ambient of 18–20 ° C temperature at zebytypes cattle this index is equal to 1.047 ± 0.089 p., and at a blackly-pied breed and brown Latvian breed, according to 0.982 ± 0.071 and 1.001 ± 0.062 p. With the increase of temperature of air to 40–43 ° C as com-

pared to a zebytypes cattle duration of cycle of R – R at a blackly-pied breed went down on 16.3%, and at the brown Latvian breed on 14.4% ($p < 0.05$).

The diastole phase of T-P at the investigated breeds at the temperature of 18–20 ° C made: at the zebytypes cattle of 0.321 ± 0.041 c, and at blackly-pied and brown Latvian breeds accordingly: 0.360 ± 0.41 c and 0.310 ± 0.039 c. At the increase of temperature of air to 43 ° C as compared to the improved type of zebytypes cattle this index went down at a blackly-pied breed on 14.5%, and at the brown Latvian breed on 13.0% ($p < 0.05$). At a temperature 18–20 ° C time of electric systole (Q– T) time at a zebytypes cattle corresponded 0.472 ± 0.054 s., and the blackly-pied and brown Latvian breed of 0.430 ± 0.027 s. and 0.469 ± 0.027 s. accordingly. At increase of temperature to 43 ° C this index at the improved zebytypes cattle went down on 25.9%, and at a blackly-pied breed on 28.7% and at the brown Latvian breed on 22.4% ($p < 0.05$).

According to data of axonometry, electrocardiograms of cows of different breeds got by us with the different degree of thermostableness on the high temperature of air (40–43 ° C) and sunny insolation, are characterized the different sizes of vectors of P, S, T in sagittal projections (table 1).

Table 1. Indexes of size of vectors of P, S, T in sagittal projections from data of axonometry for the cows of different breeds, (M + m, n = 15)

Breed	temperature. ° C	Amplitude of indents of ECG. mV		
		P	S	T
the Improved zebytypes cattle	18–20	0.210 ± 0.021	0.397 ± 0.041	0.487 ± 0.049
	30–35	0.166 ± 0.010	0.314 ± 0.078	0.363 ± 0.058
	40–43	0.128 ± 0.012	0.284 ± 0.056	0.327 ± 0.048
Blackly-pied	18–20	0.253 ± 0.047	0.987 ± 0.078	0.498 ± 0.047
	30–35	0.179 ± 0.012	0.688 ± 0.062	0.223 ± 0.038
	40–43	0.118 ± 0.010	0.558 ± 0.079	0.212 ± 0.029
Brown Latvian	18–20	0.220 ± 0.019	0.857 ± 0.054	0.530 ± 0.064
	30–35	0.156 ± 0.028	0.654 ± 0.076	0.30 ± 0.063
	40–43	0.120 ± 0.014	0.543 ± 0.048	0.301 ± 0.065

As be obvious from a table, for cows blackly-pied and brown Latvian breeds at the increase of temperature of air (40–43 ° C) the size of vector of P in a sagittal projection went down accordingly to 0.118 ± 0.010 and 0.120 ± 0.114 mV, vector of Ton – accordingly to 0.212 ± 0.29 and 0.301 ± 0.065 mV, and also vector of S accordingly to 0.558 ± 0.079 and 0.543 ± 0.048 mV. It is necessary to

mark that at such terms an experiment indexes of ECG at a zebytypes cattle is characterized the less changes of size of vectors as compared to the imported breeds of animals.

Undertaken studies allowed to trace the pedigree feature of bioelectric activity of heart for the cows of different breeds at different temperature intervals, and also to set conformity to law of these changes. Thus, the cows

of different breeds at influence of different temperatures have unidirectional functional changes in the operation of heart. At the same time, we will mark that these

changes are less expressed for the cows of the improved zebytypes cattle, what for the cows of imported breeds (blackly-pied, brown Latvian).

References:

1. Ajibekov M. A. Physiological adaptation of animals in the conditions of roast климата. – Nukus, Karakalpakstan. – 1996. – 176 p.
2. Mezenceva L. V. Fibrillation of ventricles of heart: modern methods of analysis of degree of irregularity of process // Successes of physiological sciences – 2000. – Т. 31– No. 3. – С. 70–79.
3. Mezenceva L. V., Percov S. S. Stability of physiological functions and methods of her estimation // Announcer of medical NT – 2014. – Т. 21 (1). – С. 12–17.
4. Merkureva E. K. Biometry in a selection and genetics agricultural животных. – М., Kolos. – 1977. – 191 p.
5. Roshevsky M. P. Electric activity of heart and methods of survey of electrocardiograms at large horned скота. – Sverdlovsk. – 1958. – 79 p.
6. Roshevsky M. P. Electro-cardiology hoof of animal. – М., Nauka. – 1978. – 298 p.

*Khusanov Tokhir,
Junior researcher, of the Institute
of Microbiology of the Academy of Sciences
of the Republic of Uzbekistan
E-mail: tohir_husanov@mail.ru*

*Davranov Qodirjan,
doctor, of Biological Sciences,
National university of Uzbekistan
after named Mirzo Ulugbek*

*Vakhobov Abdurasul,
doctor, of Biological Sciences, professor,
National university of Uzbekistan
after named Mirzo Ulugbek*

EFFECT OF ALFALFA MOSAIC VIRUS ON THE CONTENT OF MICRO AND MACROELEMENTS IN ALFALFA PLANTS IN UZBEKISTAN

Abstract: Leaf samples showing mosaic virus symptoms were collected for analyses from alfalfa growing areas in botanical garden of The National university of Uzbekistan. Alfalfa mosaic virus (AMV) was detected in the plant samples by using mechanical inoculation of test plants and visual determination. The macro and microelements were assayed in the infected plant samples in order to determine the effects of AMV on the nutrient content of alfalfa. The content of micro and macro elements decreased, as well as the amount of peroxidase in the infected alfalfa leaves as compared to the healthy plant samples.

Keywords: alfalfa mosaic virus, peroxidase, micro and macro-elements, photosynthesis.

Introduction

Microelements as cobalt, boron, manganese, zinc, molybdenum, copper, iron, which are required for the normal growth and development of plants, directly participate in metabolism. Also they play important role in the management of enzyme systems involved in complex biochemical and physiological process occurring in body. Trace elements are important in the life processes of plants, animals and people, if their number is not enough or more, or even none, then metabolism is disrupted [1, 2, 3, 4]. Long-term studies conducted by physiologists and agro chemists have shown that in order to fully grow and develop such basic crops as cotton, alfalfa, corn, etc., microelements should be in the appropriate amount in the soil [1, 3, 5]. In plants, the cations Na^+ and Cu^{+2} , passing through semipermeable membranes of the cell wall, are considered to be elements that change the pH of the cell sap. Therefore, these elements play

an important role in the plant cell [2, 4]. Cu^{+2} is an element affecting the amount of chlorophyll, decrease in the amount of this microelement adversely affects the process of photosynthesis. Lack of iron element leads to chlorosis of the plant [1].

Based on the above stated, this article describes research on the effect of viral damage to lupine plants, on the change in the number of micro and macro-elements and the activity of the enzyme peroxidase.

Materials and Methods

Samples exhibiting mosaic virus symptoms were collected from growing areas in botanical garden of National university of Uzbekistan. We weighed the initial mass of samples, then dried them in an oven to absolute weight and re-weighed and stored in paper bags. For the study, slurry of a certain number of samples was ground to a homogeneous mass, then the amount of microelements was analyzed by neutron activation [6, 7, 8].

To determine the activity of the enzyme peroxidase in the infected plants, samples from alfalfa leaves of weakly, medium and heavily infected and healthy plants of 10 ml were weighed on an electronic scales in the ratio 1: 1 (10 ml) with the addition of acetate (CH_3COOH) buffer (pH- 4.7 0.04 M), ground in a porcelain mortar to a uniform mass, filtered through 4 layers of gauze, centrifuged for 15 minutes at 4000 rpm to precipitate the constituent parts of the cell. The supernatant was mixed in numbered tubes in the presence of the enzyme peroxidase, determined by the Boyarkin method. In order to achieve this, 2 drops of supernatant, 0.4 ml of benzidine

solution, 0.2 ml of distilled water and 0.2 ml of H_2O_2 and a photocolimeter with a red light filter at 640 nm of the wavelength, the activity of the enzyme was determined on the basis of the rate of the reaction [9, 10].

Results and discussion

When monitoring the fields in which alfalfa was grown, its AMV affection was established. A wide spread of the disease in phenological observations was manifested by splitting plant pigments, the symptoms of a mosaic (Fig. 1). It is known that when the virus is severely affected by the virus, the amount of chlorophyll is greatly reduced in plants, and this affects the yield of alfalfa.



Figure 1. A) strongly injured; B) medium affected; C) healthy plants

The infection with virus leads to a decrease in the pigment in the leaves, a change in the process of photosynthesis and transpiration. In this case, the photochemical activity, transcription and other important physiological processes are violated, which leads to a tangible loss of

the quality of the plant product and the amount of alfalfa biomass.

Alfalfa along with other crops is important in animal husbandry and other branches of the national economy. Because of the large accumulation of nitrogen in the roots

of alfalfa plants, the nutritional value of fodder is much greater. Therefore, it is important to animal husbandry. The literature indicates that the amount of alfalfa affected in the plant is 35%. Alfalfa from the atmosphere gets free nitrogen and transforms it into a state assimilated by the plant. In plants, alfalfa also contains a large number of vitamins, proteins, mineral elements and their residues.

As stated earlier, microelements (boron, manganese, molybdenum, iron, zinc, copper) in minimum quantity are necessary for the normal development of the plant. They participate in the process of metabolism, have a definite place in the management of the action of enzyme complexes involved in complicated processes of organism.

Investigations on the effect of infected alfalfa AMV plants on the composition of micro and macro-elements

are given in (Table 1). The data show that when AMV is infected in plant leaves, the amount of Fe, Cu, Zn, Ba, Br, Na and Ca is significantly reduced. Reducing the amount of chlorophyll in a plant cell can lead to physiological changes. Amount of Mg and Cs is increased, the amount of As is not sensitive. The increase or decrease of micro and macroelements in case of infection with a viral disease leads to profound changes in the metabolism of plants, i.e. activity of photosynthesis, transpiration and other important processes.

The cations Na^+ , Ca^{+2} in plants passing through semi-prescribed membranes of the cell wall change the ionic strength (pH) of the cell sap.

Reduction of these elements adversely affects the complete course of physiological processes in the plant cell.

Table 1. – Quantity of micro-macro-elements in mg

No	Elements	Healthy plant, mg	Slightly infected, mg	Medium infected, mg	Strongly infected, mg
1	2	3	4	5	6
1.	Mg	3000	3500	3300	4700
2.	Cl	965	4100	2850	3500
3.	Mn	67	40	43	40
4.	Cu	19	13	15	17
5.	Na	160	150	99	88
6.	K	28000	41000	32000	34000
7.	Sm	0.0078	0.012	0.0079	0.0096
8.	Mo	13	<0.1	5.0	5.5
9.	Lu	<0.001	<0.001	<0.001	<0.001
10.	U	<0.1	<0.1	<0.1	<0.1
11.	Au	0.0099	0.0054	0.0092	0.019
12.	As	<0.1	<0.1	<0.1	<0.1
13.	Br	1.1	2.0	3.9	4.7
14.	Ca	23000	15100	16100	15700
15.	La	0.059	0.054	0.066	0.088
16.	Ce	0.13	0.18	<0.1	0.22
17.	Hg	0.015	<0.01	0.015	<0.01
18.	Th	0.019	0.022	0.034	0.031
19.	Cr	0.23	0.36	0.28	0.38
20.	Hf	0.014	0.0087	0.0087	0.011
21.	Ba	36	21	17	18
22.	Sr	230	260	180	170
23.	Cs	0.020	0.025	0.042	0.060
24.	Ni	4.9	<1.0	8.2	7.1
25.	Sc	0.018	0.020	0.023	0.028

1	2	3	4	5	6
26.	Rb	8.1	13	14	30
27.	Zn	36	40	49	51
28.	Co	0.31	0.26	0.40	0.39
29.	Fe	110	130	150	130
30.	Eu	<0.001	0.0026	0.0039	0.0024
31.	Sb	0.022	0.027	0.031	0.041
32.	Ag	<0.01	<0.01	<0.01	<0.01
33.	Ti	<10	<10	<10	<10
34.	V	3.0	<1.0	<1.0	<1.0
35.	W	<0.1	<0.1	<0.1	<0.1

Cu^{+2} is a microelement that affects the amount of chlorophyll and a decrease in its amount adversely affects the process of photosynthesis.

In the conducted studies it was found that infecting plants with AMV, the amount of heavy metals in the plant is slightly reduced, and a decrease in the amount of light metals can lead to profound changes in the cell.

The enzyme complex, photosynthesis, respiration and oxidation-regeneration processes are involved in the performance of very important physiological functions occurring in plants. According to literary sources,

peroxidase enzyme contained in the oxidoreductase is considered a stress enzyme, penetration into the cell of a foreign antigen increases its activity [10].

The peroxidase enzyme is an iron-porphyrin enzyme, in the cell it has a functional dependence in plants, horseradish plants are studied in detail, where the activated oxidative phosphorylation catalyzes the oxidation of pyridine coenzymes. Table 2 shows the results of studies on the enzyme activity in the cell of alfalfa plants when infected with viruses.

Table 2. – Influence of virus infection on the activity of the peroxidase enzyme in the leaves of the alfalfa plant (mg / U)

№	Samples	Number of replicates			Average
		Experience 1	Experience 2	Experience 3	
1.	Healthy alfalfa	0.192 ± 0.03	0.152 ± 0.01	0.143 ± 0.019	0.162 ± 0.01
2.	Slightly infected	0.192 ± 0.02	0.166 ± 0.01	0.142 ± 0.02	0.165 ± 0.01
3.	Medium infected	0.476 ± 0.06	0.408 ± 0.008	0.363 ± 0.053	0.416 ± 0.008
4.	Strongly infected	2.00 ± 0.34	1.428 ± 0.22	1.538 ± 0.11	1.655 ± 0.117

From the results presented, it can be seen that the amount of enzyme and ego activity in healthy and slightly infected plants does not significantly differ. The amount of enzyme and its activity sharply increases in medium and strongly infected plants. When a pathogenic virus enters the cell of the plant, genes are activated that perform stressful functions in extreme cases and, so an increase in the amount and activity of the enzyme may occur. Some literature cited information that this enzyme is a stress enzyme and when affected by various pathogens, and in other extreme cases, its amount increases several times compared to control [9, 10].

Physiological and biochemical processes, including respiration, photosynthesis, transpiration, photo-

chemical reactions, mineral nutrition and many other processes taking place in the living organism occur with the participation of enzymes. In the classification and nomenclature this enzyme is introduced into the group of oxidoreductases, it activates oxidative phosphorylation, catalyzes the oxidation of pyridine coenzymes in a plant cell. Participates in the management of a number of processes associated with oxidation-reduction reactions [10].

The obtained data indicates the expediency of carrying out further experimental studies to clarify the participation of the enzyme in photosynthesis disturbance, transpiration intensity, photochemical activity and a number of other physiological and biochemical

processes following the penetration of the virus into the plant cell, and subsequent changes in the number of micro and macroelements, pigment complexes, enzyme peroxidase.

References:

1. Davronov Q. S., Usmonov R. M., Kuchkarova K. K., Yulchiev E. Y. Influence of ultrafine powders of iron and copper on the growth of cotton development // *Agricultural Biology*.– Moscow,– 2006.– No. 6.– P. 58–61.
2. Zorin E. V., Folmanisc G. E. Ultrafine iron powders // *Monthly Scientific and Production Journal “Sugar beet”*.– Moscow,– 2001.– No. 5.– P. 76–78.
3. Nejla Yardımcı, Handan Eryiğit and İbrahim Erdal. “Effect of alfalfa mosaic virus (AMV) on the content of some macro- and micronutrients in alfalfa” // *Journal of culture collections*.– Volume 5.– 2006–2007.– P. 90–93.
4. Walinga I., W. Van Vark V.J. G. Houba J.J. Van der Lee,– 1989. *Soil and Plant Analysis*, Wageningen, The Netherlands: Wageningen Agricultural University.
5. Bremner J.M. *Methods of Soil Analysis*, Madison: American Society of Agronomy Inc.– 1965.
6. Vaganov P. A., Luknitskiy V. A. Neutrons and criminology // Leningrad,– 1981.– 192 p.
7. Kuznetsov R. A. *Activation analysis* // – Moscow,– 1974.– 343 p.
8. Maslov I. A., Luknitskiy V. A. *A Guide to Neutron Activation Analysis* / – Leningrad,– 1971.– 312 p.
9. Aleksandrova E. Y. The study of peroxidase activity in extracts from rhizome and horseradish roots and its stability to various effects // *Bulletin of Moscow University*,– 2006.– No. 5.– P. 350–352.
10. Rogojin V. V. Peroxidase as a component of the antioxidant system of living organisms // – Moscow,– 2004.– 240 p.

Sharipov Odiljon Bafoevich,
Senior lecturer, Faculty of Natural Sciences
Bukhara State University,
E-mail: Sharipov3003@mail.ru

Gafurova Lazizakhon Akramovna,
doctor, of Biological Sciences, professor,
Biology and Soil Faculty
National University of Uzbekistan,
E-mail: glazizakhon@yandex.ru

BIOLOGICAL ACTIVITY OF IRRIGATED GRASSLAND ALLUVIAL SOILS OF THE BUKHARA OASIS

Abstract: In the course of research, soil sections were cut taking into account the degree of salinity, the duration of irrigation, the mechanical composition; the profile structure, the morphological indices, the agrochemical, chemical and microbiological properties of saline soils of the Bukhara Oasis were studied. Experiments on agro-biotechnological methods of increasing fertility in the “Bafu Mardon Sharif” farm in the Bukhara region of the Bukhara district were conducted.

Keywords: soil, salinity, soil fertility, microbiological activity, bacterial preparations, molecular biological analysis, ammonifying microorganisms, fungi, actinomycetes, spores, nitrogen fixators, cotton growing, germination energy, crop yields.

Introduction: In recent years in many countries, including Uzbekistan, numerous studies have been carried out to investigate the soil biology and to introduce the agro-biotechnology in agriculture, to increase soil fertility; ideas on the role of biological activity in the soil-forming process are developing, in the growth and development of agricultural crops, in mobility of nutrient macro- and microelements, in increasing plant resistance (to salinity, drought, pollution, climate changes, etc.) [3, 5].

Thus, the increase in the yield and quality of agricultural cultures, particularly in arid areas and on saline soils, can be achieved through the high-culture farming by scientifically sound ecologically safe use of new types of bio-fertilizer and biologics, sowing new forms of leguminous plants (especially leguminous vegetable), bioremediation with halophytes that have a positive effect on the microbiological and enzymatic activity, soil respiration and the processes of humus-forming in soil, nutrient, water, thermal soil regimes, soil-forming processes, soil evolution, and, finally, soil fertility and productive capacity [2, 6]. It follows from the above that the tasks posed in the paper are urgent: to study the properties of peculiar arid soils, to determine and introduce new

agro-biotechnologies to increase soil fertility in conditions of the Bukhara oasis (for example, in soils of the Bukhara region).

Objects and methods of research: The object under study is an irrigated grassland soils of the Bukhara oasis. The tasks are solved on the basis of the principles of comparative-geographical, stationary, laboratory methods for studying the topsoil. Materials of long-term researches carried out by scientists and the authors in 1970–2015 have been generalized. The methods of mathematical statistics (according to Dospekhov’s) were used in generalizing and analyzing the data obtained. In the course of studies, 12 supporting sections have been cut in different regions, taking into account the soil conditions, the degree of salinity, the duration of irrigation and tillage, the type of agricultural use. Vast studies of the morphogenetic and physical properties of soil were carried out at stationary sites in field conditions [8].

Humus, gross nitrogen, phosphorus, potassium, mobile phosphorus and potassium, CO₂ carbonates, SO₄ gypsum, salt composition, and mechanical composition in soil samples were determined with the standard methods of the Analytical Center of the Institute of Soil Science

and Agrochemistry of the State Committee for Geodesy (Methods of agrochemical analysis of soil and plants of Central Asia. Tashkent, 1977), Guidelines for conducting chemical and agrophysical analysis of soils in land monitoring. Tashkent, 2004; 1975. Guidelines for chemical analysis of soils (Arinushkina, 1970), Methods for studying physical properties of soils (Vadyunina, Korchagina, 1986) [9].

Characteristics of soils of the experimental site of the “Bafo Mardon Sharif” farm: The “Bafo Mardon Sharif” farm is located in the “Rabotikalmok (Madaniyat)” massive of the Bukhara region of the Bukhara

district. In this region, soil presents mainly an irrigated grassland alluvial soil of the II terrace of the Zarafshan river (23 differences), irrigated grassland soil of I terrace of the Zarafshan river (6 differences), irrigated gray-brown-grassland soil. In this region the soils of different degree of salinity are found: slightly-, medium- and highly saline differences.

The level of groundwater in irrigated grassland alluvial soils is about 2–2.5 m.

Mechanical composition of irrigated grassland soils

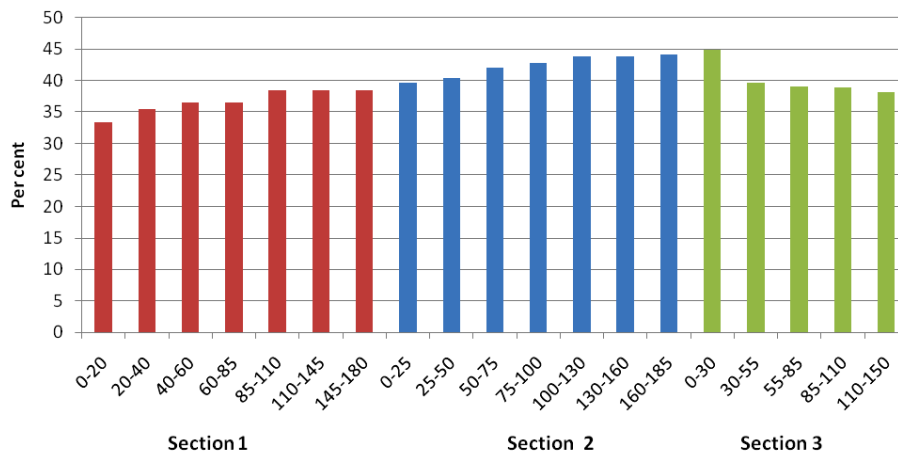

Figure 1. Physical clay

Mechanical composition of the arable horizon includes medium loamy soils, in the middle part of the profile – heavy and medium loamy soils, downward to the lower layers – medium- and light-loamy soils, in some places medium-loamy soils.

The humus content is from 0.78 to 1.05%, the degree of salinity is from slightly to moderate salinity (dense residue –

0.202–0.704%, CI 0.038–0.067%. SO_4^{2-} 0.134–0.306%). Mobile P_2O_5 is from 15,8 to 17,0, K_2O from 100 to 190 mg/kg.

The content of humus and nutrients in irrigated grassland soils of the Bukhara Oasis

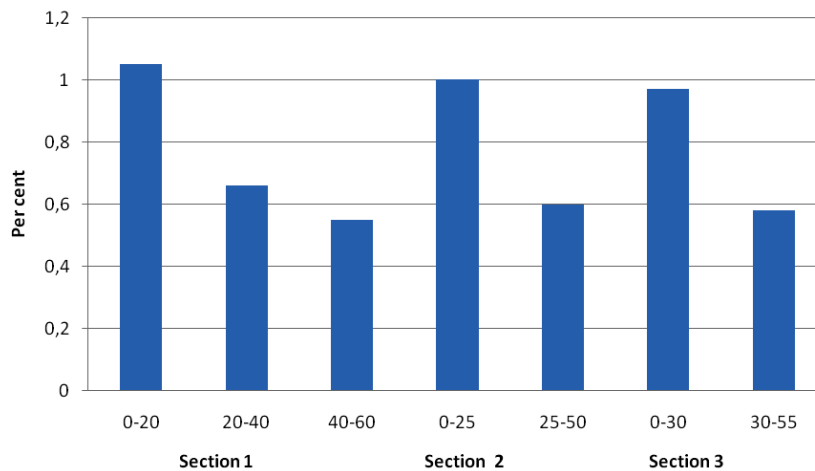

Figure 2. Humus

The content of nutrients in irrigated grassland soils of the Bukhara Oasis.

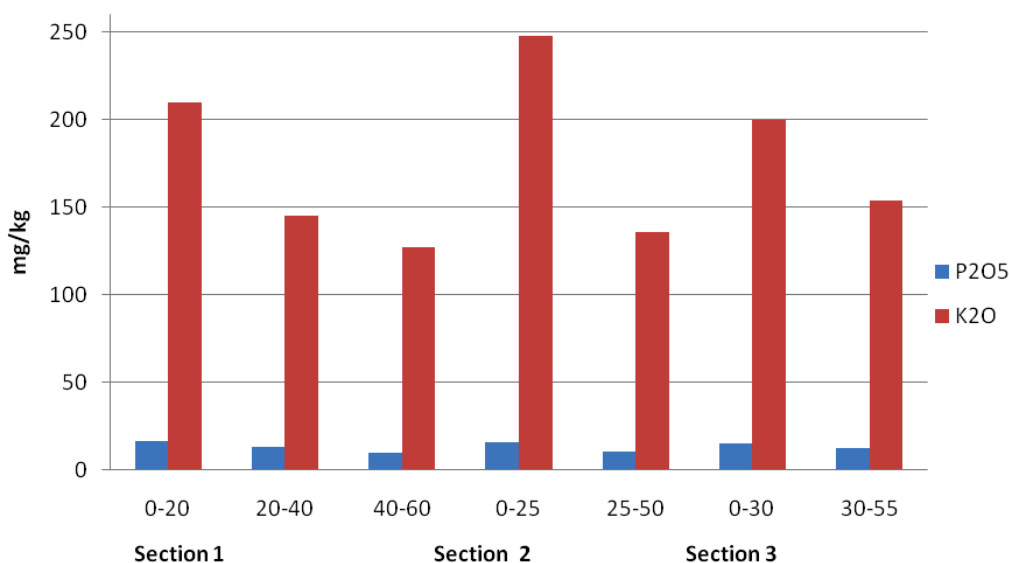

Figure 3. Phosphate and Potassium

Experimental part: In field experiments, a quarterly selection of soils was carried out during the experiments in order to study their biological activity.

Field experiments were conducted on irrigated grassland alluvial soils. Cotton variety was Bukhara 6. The bio-fertilizer “Mikroustirghich” and the biopreparation “Trichodermin” were tested in production conditions of farming. These biopreparations and biofertilizers are used in presowing seed treatment, root and foliar feeding of cotton plants, wheat and repeated crops. At the end of experiments, manual harvesting was carried out and the yield of raw cotton was recorded to determine the technological qualities of the fiber. The yield of cotton was determined by manual harvesting, and the results have shown that the main crop was obtained at the first harvest – about 70%.

Discussion of results. In the course of studies, the main population changes were studied under the influence of salinity in the main groups of microorganisms, and along the soil profile.

Analysis of publications has shown that under extreme conditions of salinization the halo-tolerant bacteria *Bacillus* and *Micrococcus* grow better than the halophilic bacteria *Halobacterium* and *Alococcus*, even at 10–15% of the dense residue in the medium [5, 6, 7].

We have studied the microflora of irrigated grassland alluvial soils in the Bukhara Oasis. A survey of the bio-

logical activity of six sections of soils was carried out, samples were taken from a depth of 0–5, 5–15, 15–30, 30–50, 50–70 cm.

Studies have shown that not all groups of microorganisms are present in these samples. Thus, the MPA revealed the greatest variety of morphological and physiological groups (bacillus with and without spores, actinomycetes and cocci, like staphylococcus). Nitrogen-fixing microorganisms in the Ashby medium are revealed, mainly, in a 10^{-2} dilution. Exceptions were the samples, where nitrogen-fixing bacteria in a larger number were detected in almost all horizons.

The horizon of 5–15cm is represented by flat, scattered colonies of gray color with even and uneven edges. In the deeper samples, mainly mucous semitransparent colonies are identified. Despite the small morphological diversity of microorganisms, the cell titer of MPA in each horizon is high. In the 0–5cm horizon, the cell titer / ml is on average $1 \cdot 10^6$, in the horizons 5–15cm it is $1 \cdot 10^5$, in the horizons 15–30 cm, 30–50 cm, and 50–70 cm the cell titer is from 10^5 to $2.5 \cdot 10^5$.

Thus, soil samples of the Bukhara region in the MPA are very different both in the morphology of the colonies and in their number. Morphological diversity of cultures in samples is narrowed with depth.

The number of studied groups of microorganisms decreases in a series of weakly saline, medium – and

highly saline soils. As salinization increases, such forms of microorganisms develop that can easier tolerate unfavorable environmental conditions, (actinomycetes and spore bacteria), this indicates the energetic mineralization processes that result in low humus content.

Conclusion. Results of field research have shown the effectiveness of agro-biotechnology in the cultivation of cotton variety Bukhara 6 on irrigated grassland soils, as the year

2015 was somewhat unfavorable, dry, with high summer temperatures, dry winds, etc. In addition, soil was slightly saline, compacted with low humus and nutrient reserves.

Results has shown that in the control variant the yield of cotton was 36.6 c/ha, and in the second variant – 39.7 c/ha, in the third – 30.3 c/ha, in the fourth variant – 40.1 c/ha. Thus, when using biopreparations, the yield of cotton is 3–4 c/ha higher than the control variant.

Table 1. – The yield of cotton variety Bukhara 6 on irrigated grassland alluvial soils, c/ha

Variants	Repetitions			average	Including harvesting		Harvest fracture	
	I	II	III		I	II	I	II
Control	36.2	37.7	36.6	36.6	25.2	11.4	68.9	31.1
Baikal M 1	40.4	38.6	40.2	39.7	27.1	12.6	68.3	31.7
Microustirghich	40.3	40.0	46.5	40.3	27.2	13.1	67.9	32.1
Trikhodermin	40.2	40.2	40.1	40.1	27.3	12.8	68.2	31.8

Note that the Baikal M 1 was adopted as the standard for comparison of biopreparation Trichodermine and Microustirghich and control without treatment. The presowing soaking of cotton seeds with the Microustir-

ghich preparation of 100 ml/t followed by spraying the vegetating plants promotes an increase in the germination capacity of seeds and the germination energy is greater than that of the control and reference variants.

References:

1. The Land Fund of the Republic of Uzbekistan. National Report of the State Committee of Land Resources, Geodesy, Cartography and State Cadastre. – 2014. – 18 p.
2. Eroded Soils of the Turkestan Range and Their Biological Activity – Tashkent: Fan, – 2014. – 93 p.
3. Gafurova L. A., Saidova M. E. Soils near the Aral Sea and their Biological Activity. Tashkent: Fan, – 2015. – P. 108–109.
4. Kuziev R. K., Sectimenko V. E. Soil of Uzbekistan. – Tashkent, – 2009. – 272 p.
5. Gafurov K., Abdullaev S. Characteristics of Topsoil of the Irrigated Zone of the Bukhara Region. – Tashkent: Fan, – 1984. – 25 p.
6. Dzhumaniyazova G. I. Phosphoro-mobilizing Bacteria and Biofertilizers on their Basis, Thesis of Doctor of Biological Sciences. – Tashkent. – 2012.
7. Methods of Soil Microbiology and Biochemistry. Textbook / Ed. by D. G. Zvyagintsev. – Moscow: MGU, – 1991. – 304 p.
8. Methods of Field and Vegetation Experiments with Cotton. – Tashkent. SNIHI, – 1973.
9. Agrochemical Methods of Soil Investigation. Manual for Field and Laboratory Research. 3rd ed. – Moscow, – 1960.

Yusupova Umida Rakhmanovna,
Senior teacher, National University of Uzbekistan

Botirov Erkin Khojiakbarovich,
Head of Chemistry department, professor,
Surgut State University

Almatov Karim Tajibayevich,
doctor, of biological sciences, professor,
E-mail: umidayusupova21@gmail.com

INFLUENCE OF HAPLOGENIN – 7 – GLYCOSIDE ON RESPIRATION AND OXIDATIVE PHOSPHORYLATION OF RAT LIVER MITOCHONDRIA

Abstract: It has been established that *haplogenin – 7 – glycoside* increases mitochondrial respiration of rat liver. Thus the ADP/O quotient increases slightly by glutamate, and by succinate on the contrary, decreases imperceptibly.

Keywords: flavonoids, haplogenin, oxidative phosphorylation, rat liver, mitochondria, glutamate, oxygen.

Introduction

It is known that in mitochondria occur processes as a result which energy accumulates in cells and these organelles possess all main functions of independent organism such as reduction, ion transportation and heredity [1]. It allows considering that mitochondria are rather complete substances of a living matter preserving their basic properties. If this so, a response of isolated mitochondria – their metabolic stations – should correspond to physiological laws of influence of living organisms on external actions. Differently, it is possible to believe that there is a correlation between metabolic station of isolated mitochondria and such stations, as excitation and braking. These terms often use for the description of system reactions of the whole organism. We use them in that sense in what they are applied in physiology to a designation of the basic laws of influence of a living tissue on external actions.

It's established that flavonoids possess anti-inflammatory, antiatherogenic, antiviral, anticytotoxic, membrane – stabilization [2, 3], anti-cancer, cytoprotective [4–6], neurocytoprotective [7–10] immune-modulation [11, 12] properties. However the questions, concerning influences haplogenin-7-glycoside on structure and functions of mitochondrial membranes still aren't studied.

Research an effect of haplogenin-7-glycoside on respiration and oxidative phosphorylation is of interest not only from a position of clarification of physiological and biochemical mechanisms the regulation of an organism activity, but also for an establishment pathogenetic importance of these parameters at various stressful influences and diseases.

Materials and Methods

Mitochondria were isolated from cells of rat liver according to a method [13]. Velocity of mitochondrial respiration at a various metabolic states was registered polarographically with the help of the rotating platinum electrode. Reactions were started with addition of a mitochondrial suspension into polarographic cell. An incubation medium has the following composition: sucrose – 0.25 M, KH_2PO_4 – 5 mM, tris-HCl – buffer – 10 mM (pH 7.4). As oxidizing substrata were used 10 mM of succinate (pH 7.4) and 10 mM glutamate (pH 7.4). Mitochondrial respiration and oxidative phosphorylation were analyzed at the consecutive addition 200 μM of haplogenin-7-glycoside and ADP, $5 \cdot 10^5$ M of 2,4 – dinitrophenol (DNP). Herewith the following velocity of respiration chemicals were determined: V_2 – state 2 before the addition of ADP, V_3 – active phosphorylation state, V_4 – state 4 after an exhaustion of ADP in the polarographic cell; ADP/O ratio and respiration control quotient were calculated by a method of Chance and

Williams ($V_3:V_4$) [14]. Velocity of the substrata oxidation at a various metabolic states was expressed in nanogram atom oxygen min/mg of mitochondrial protein. Protein was defined by a method of Lowry et al. [15].

Experiments were carrying out in absence of flavonoids and with addition haplogenin-7-glycoside into a polarographic cell in vitro. Haplogenin-7-glycoside was used in a manner of glycerin solution. The specified flavonoids were put into polarographic cell in final concen-

tration 20, 40, 60 mcgr/mg mitochondrial protein and studied the features of change of mitochondrial functional state. Haplogenin-7-glycoside has been kindly given by officials-professors Khushbaktova Z. A. and Syrov V.V. of Institute of Plant substances' chemistry.

Results and discussion

Influence of haplogenin-7-glycoside on glutamate oxidation and oxidative phosphorylation of mitochondria was resulted in the (Table 1).

Table 1.– Influence Of Haplogenin-7-Glycoside On Glutamate Oxidation And Oxidative Phosphorylation Of Liver Mitochondria ($M \pm m$; $n = 5-6$).

Readings	Respiration rate, nanogram atom oxygen/ min mg of protein			
	haplogenin-7-glycoside, mcg/mg of protein			
	0	20	40	60
V_2	18.0 ± 1.2	18.6 ± 1.4	19.0 ± 1.2	20.5 ± 1.6
%	100	103.3	105.5	113.9
V_3	54.5 ± 1.8	57.4 ± 2.2	$60.3 \pm 1.9^*$	$73.0 \pm 1.8^{***}$
%	100	105,3	110,6	133,9
V_4	17.6 ± 1.4	17.8 ± 1.4	17.9 ± 1.3	20.8 ± 1.7
%	100	101.1	101.7	118.2
V_{DNP}	68.8 ± 1.8	75.5 ± 2.2	$80.0 \pm 2.4^*$	$96.5 \pm 2.4^{****}$
%	100	109,7	116.3	140.2
$RC_{Ch}(V_3:V_4)$	3.09 ± 0.10	3.22 ± 0.10	$3.37 \pm 0.09^*$	$3,51 \pm 0,10^{**}$
%	100	104.2	109.0	113,6
ADP/O	2.37 ± 0.09	$2.81 \pm 0.13^{**}$	$3.00 \pm 0.14^{***}$	$2.85 \pm 0.10^{**}$
%	100	118.4	126.4	120.3

*A note: Here and in the table 2 the quotient authenticity was marked: * $P < 0.05$; ** $P < 0.002$; *** $P < 0.01$; **** $P < 0.001$.*

Haplogenin-7-glycoside, in low concentrations (20 $\mu\text{g}/\text{mg}$ of protein) wasn't influence on glutamate oxidation and a respiration control value on Chance, however rose ADP/O quotient up to 18.4%. It's known that if a respiration control value on Chance reflects the degree of relationship of transformation processes and energy accumulation by mitochondria with energetic processes in the cell, that ADP/O value characterizes the functional organization of mechanisms, defining an ADP phosphorylation process in mitochondrial membrane and their relationship with activity of a terminal respiratory chain. The more a value of ADP/O, the less oxygen spent to phosphorylation, that accordingly higher mitochondrial coefficient of efficiency from energy storage point of view for further intracellular metabolic processes. The increase of haplogenin-7-glycoside concentration entered into the polarographic cell twice phosphorilative oxida-

tions of glutamate (V_3) raises on 10.6% from control level. As a result, the value of the respiratory control on Chance and ADP/O quotient raised on 9.0 and 26.4%, respectively, from control level. The further increase of haplogenin-7-glycoside concentration (60 mkg/mg of protein) raises glutamate oxidation in various metabolic conditions of mitochondria.

Thus, a mitochondrial respiration in V_2 , V_3 and V_4 states increases on 13.9; 33.9 and 18.2% respectively, in comparison with control. Increase of respiration in phosphorylation condition leads to increase of value of the respiratory control on Chance and ADP/O quotient on 13.6 and 20.3%. It means that haplogenin-7-glycoside is a respiratory activator and especially, ATP synthesizing function of mitochondria at oxidation of NAD – dependent substrates.

Influence of haplogenin-7-glycoside on succinate oxidation and oxidative phosphorylation of liver mitochondria is summarized in (Table 2).

In low concentration (20 mkg/mg of protein) haplogenin-7-glycoside slightly (on 12.9%) increases succinate phosphorilative oxidation. At the same time respiration of mitochondria in V2 and V4 metabolic states and value of respiration control on Chance hasn't change, however ADP/O quotient decreases to 12.1%. The increase of haplogenin-7-glycoside concentration, entered into a polarographic cell in two times leads to increase phosphorilative oxidation of succinate (V3) to 24.9% from control level, and respiration of mitochondria at the calm state (V4) – to 24.9%. Thus, value of the respiratory control on Chance does not change,

however the ADP/O quotient raises on 16.0%. The further increase of haplogenin-7-glycoside concentration (60 mkg/mg of protein) leads to increase of succinate oxidation in various metabolic states of mitochondria. Thus respiration of mitochondria in V2, V3 and V4 states increases in comparison with control on 16.7; 39.8 and 34.7%, respectively. It means that haplogenin-7-glycoside is the activator of the respiratory functions of mitochondria at oxidation of succinate oxidation pathway. Thus, the value of the respiratory control on Chance does not change, however ADP/O quotient decreases on 17.6%.

Table 2. – Influence of haplogenin-7-glycoside on succinate oxidation and oxidative phosphorylation of liver mitochondria ($M \pm m$; $nb = 8-12$)

Readings	Rate of respiration, nanogram atom oxygen/min mg of protein			
	Haplogenin-7-glycoside, mcg/mg of protein			
	0	20	40	60
V ₂	40.0 ± 2.4	40.9 ± 2.7	42.4 ± 3.2	46.7 ± 4.0
%	100	102.2	106.0	116.7
V ₃	112.0 ± 3.6	126.5 ± 4.4 [†]	144.4 ± 5.7 ^{***}	156.6 ± 6.5 ^{****}
%	100	112.9	128.9	139.8
V ₄	32.5 ± 2.5	34.8 ± 3.0	40.6 ± 3.5 [*]	43.8 ± 3.7 ^{**}
%	100	107.0	124.9	134.7
V _{DNP}	130.6 ± 5.6	144.5 ± 6.0	180.0 ± 6.4 ^{***}	200.0 ± 7.7 ^{****}
%	100	110.6	137.8	153.1
RC _{Ch} (V ₃ : V ₄)	3.44 ± 0.13	3.63 ± 0.12	3.55 ± 0.12	3.57 ± 0.09
%	100	105.5	103.2	103.8
ADP/O	1.82 ± 0.09	1.71 ± 0.08	1.53 ± 0.11 [†]	1.50 ± 0.08 ^{**}
%	100	87.9	84.0	82.4

Depending on dose, haplogenin-7-glycoside raises dinitrophenolstimulative oxidation of substrates. So, if at the entering of haplogenin-7-glycoside into the polarographic cell in a dose of protein of 20 mkg/mg mitochondria, glutamate and succinate oxidation raise on 9.7 and 10.6% from control level, at the entering of protein of 40 mkg/mg – 16.3 and 37.8%, and 60 mkg/mg of protein – 40.2 and 53.1%. Thus, haplogenin-7-glycoside increases transport of electrons from substrata to molecular oxygen along respiratory chain of mitochondria, and it considerably occurs on succinate oxidation pathway.

Analyzing the received results, it is possible to conclude that haplogenin-7-glycoside considerably raises mitochondrial respiration of rat liver. Thus, the ADP/O quotient with glutamate considerably raises, on the contrary, decreases with succinate.

At the analysis of oxidizing capability of mitochondria, the attention has been paid to characteristics of their conditions corresponding to a certain tissue activity. Now it became obvious that at functioning of mitochondria in vivo in quietness the main bulk of mitochondria are in a state 4 on Chance. This condition is characterized by good supply of mitochondria with oxygen and substrata. However, respiratory activity is suppressed because it is integrated to phosphorylation processes, and in a based tissue, the basic exchange fund of adenilnucleotides, using for endocellular transport of energy, appears in the form of ATP. Absence of corresponding acceptors of phosphate is the basic brake of cellular respiration. Increase of cell activity leads to energy expenses and ATP hydrolysis. Occurrence of phosphate acceptors in the form of ADP leads to activation of respiratory activity of mitochondria, and

it will proceed until cell will spend energy of macroergic phosphoric connections and deliver of ATP to mitochondria. At presence of haplogenin-7-glycoside mitochondria pass from one metabolic state in higher metabolic state. In our opinion, high intensity of metabolism can be supported animals, received haplogenin-7-glycoside at the expense of a mitochondrial activation system of various tissues and, most likely, inner organs. Increase of mitochondrial respiration by haplogenin-7-glycoside can be connected with increase of translocase activity. It has shown [16] that, exchange of adenine nucleotides (ATP^{4-}/ADP^{3-}) between mitochondrial matrix and cytosole performed by special transport system – translocase, determines total speed of respiration. With use of fluorescence probe has been shown coexistence in a membrane not only not-mobile transmitting agents (a fixated portal pore) but also mobile ones, carrying out rotate and lateral diffusion in a membrane surface [17]. The most essential line of translocase is electrogenity. It means that in energized mitochondria transport of nucleotides is performed always in one direction: ADP from cytosole into mitochondria, ATP – from mitochondria into cytosole, and K_M moreover, in 100 times higher for exogenous ATP than for exogenous ADP; relation ATP/ADP of cytosole: mitochondrial ATP/ADP is in direct linear dependence on the sizes of a membrane potential [16]. Translocase-adenine nucleotide, working synchronously with ATP-sintase and oxidizing enzymes system [18. 19] be under the control inner-mitochondrial pool of adenine nucleotides and linearly depends on the sizes of this pool [20].

In presence of haplogenin-7-glycoside increasing of ADP/O quotient by succinate and decreasing by glutamate in liver mitochondria is connected with an “anotropic electron transfer” phenomenon (restored NAD). In 1957 it has been found the phenomenon which has entered into bioenergetics under the name “oxidative phosphorylation convertibility”, or, “anotropic transport of electrons” [26]. Succinate, added to mitochondrial suspension, invoked fast reduction of mitochondrial pyridine nucleotides. After addition of ADP pyridine nucleotides acidified and only after full phosphorylation ADP, they became reduced once again. The phenomenon of anotropic transport of electrons has found a rational explanation in frameworks of Mitchell’s chemiosmotic theory [27]. It is known that from three proton pumps of a respiratory chain (respi-

ratory complexes 1, 3, 4) two (respiratory complexes 1 and 3) function reversible [28].

In vitro, for example can be created following conditions: at succinate oxidation, when the stream of protons, pumped out two proton pumps of a respiratory chain (3 and 4), will be pump inside by the proton pump I. Anotropic transport of protons correlated with anotropic transport of the electrons moving against gradient of redox potential of isopotential groups of respiratory transmitting agents at the energy expense of an electrochemical gradient of protons on a mitochondrial membrane. Thus, in this case, succinate acts both as the donor of protons, pumped out by the pumps 3 and 4, and it is inversely to protons pumped in by the pump I. As a result, it can be registered by optical methods restoration of NAD^+ . It is obvious that anotropic transport of electrons can carry out only by “energized” mitochondria, i.e. possessing an electrochemical gradient of protons on a membrane.

Thus haplogenin-7-glycoside enhancing anotropic transport process of electrons raises ATP synthesis in mitochondria. Physiologically, that process is very expediently. It is known [29] that on each NADH molecule, oxidized by oxygen, ten protons carry through a membrane. Interrelation H^+/O , equals 10. It responses to value of P/O for NAD-dependent substrates, succinate and ascorbate 10: 3 = 3, 3, 6: 3 = 2 and 4: 3 = 1, 3 respectively. It is known that extra membrane synthesis ATP from ADP and phosphate demands transport of three protons into mitochondrial matrix.

It is considered that transport of two protons is necessary for synthesis of one molecule of intra-mitochondrial ATP, while transport of one more proton provides by antiport energy



Commutation of succinate oxidation to NAD-dependent substrates at presence of haplogenin-7-glycoside represents the mechanism providing the possibility of completion of damage in high-energy compounds depot in a tissue which has arisen after excitation.

Conclusion

That commutation has an important power consequence. Considering that succinate oxidation rate is higher than NAD-dependent substrates, and transport intensity of high – energy compounds by respiration chain is higher at its burning (oxidation). This mechanism reacts as a spring, automatically backtracking

abovementioned system and is created by irritation. According to the modern biochemical reports, for realization of protein and lipid synthesis it is necessary, especially high power potential of mitochondria. Amber acid, as it is known, has no competitors in building of a high level of high-energy bonds and reduced pyridine nucleotide [30]. Therefore, it should possess specific function of plasticity maintenance. It has been

shown that at succinate use observed more complete cycle of mitochondrial changes with connection of ion transport, than at use of other substrates. It is possible to think that this commutation represents the buffer system, giving the chance to keep on the high levels of native state.

Differently, at any normal physiological activity that biochemical mechanism should be involved first of all.

References:

1. Zorov D. B., Isaev N. K., Plotnikov E. Yu et al., Mitochondria as multi-faced Janus. Review // *Biochemistry*,– 2007.– Vol. 72.– Issue 10.– P. 1371–1384.
2. Rice-Evans C. A. Parker L. (Eds.) *Flavonoids in Health and Diseases*. Marcel Dekker, – New York,– 1997.
3. Paladini A. C., Marder M. Viola H. et al. Flavonoids and the central nervous system: from forgotten factors to potent anxiolytic compounds // *J. Pharmacol.*,– 1999.– V. 51.– P. 519–526.
4. Gramaglia A., Loi G., Mongioj V., et al. Increased survival in metastatic patients treated with stereotactic radiotherapy, omega three fatty acids and bioflavonoids // *Anticancer Res.*,– 1999.– V. 19.– P. 5583–5586.
5. Hirvonen T., Pietinen P., Virtanen M. et al. Intake of flavonols and flavonones and the risk of coronary heart disease in male smokers // *Epidemiology*,– 2000.– V. 12.– P. 62–67.
6. Bagchi D., Bagchi M., Stohs I. et al. Cellular protection with proanthocyanidins derived from grape seeds // *Ann. N. Y. Acad. Sci.*,– 2002.– V. 957.– P. 260–270.
7. Wang H., and Joseph J.A. Structure – activity relationships of quer-cetin in antagonizing hydrogen peroxide – induced calcium dysregulation in PC12 cells // *Free Radic. Biol. Med.*,– 1999.– V. 27.– P. 683–694.
8. Dore S., Bastianetto S., Kar S. et al. Protective and rescuing abilities of IGF-1 and some putative free radical scavengers against beta-amyloid toxicity in neurons // *Ann. NY Acad. Sci.*,– 1999.– V. 890.– P. 356–364.
9. Bastianetto S. Ramassamy C., Dore S. et al. The ginkgo biloba extract (Erb 761) protects hippocampal neurons against cell death induced by betaamyloid // *Eur. J. Neurosci.*,– 2000.– V. 12.– P. 1882–1890.
10. Middleton E., Kandaswami C., Theoharides T. The effects of plant flavonoids on mammalian cells: implications for inflammation, heart diseases and cancer // *Pharmacol. Rev.*,– 2000.– V. 52.– P. 673–751.
11. Yuan J. and Yancuer B. Apoptosis in the nervous system // *Nature*,– 2000.– V. 407.– P. 802–809.
12. Chekman I. S. Flavonoids: clinic and pharmacologic aspects // *Herbal therapy in Ukraine*,– 2000.– V. 2.– P. 3–5.
13. Schneider W. C., Hogeboom G. N. Cytochemical studies of mammalian tissues the isolation of cell components by differential centrifugation. *Cancer. Res.*– 1951.– V. 19.– P. 1–22.
14. Chance B., Williams G. R. Respiratory enzyme in oxidative phosphorylation. 1V. Respiratory chain. *J. Biol. Chem.*,– 1955.– No. 2.– P. 429–444.
15. Lowry O. H., Rosebrough N. J., Farr A. L., Randall R. J. Protein measurement with the Folin phenol reagent. *J. Biol. Chem.*,– 1951.– V. 193.– No. 1.– P. 265–274.
16. Klingenberg M. The ADP/ATP translocation in mitochondria, a membrane potential controlled transport. *Membrane Biol.*– 1980.– V. 56.– P. 97–105.
17. Muller M., Krebs J. R., Cherry R. J., Kawato S. Rotational diffusion of the ADP/ATP translocator in the inner membrane of mitochondria and in proteoliposomes. *J. Biol. Chem.*,– 1984.– V. 259.– P. 3037–3043.
18. Gellerich F. N., Bohnsack R., Kunz W. Control of mitochondrial respiration. The contribution of the adenine nucleotide translocation depends on the ATP- and ADP consuming enzymes. *Biochem. and biophys. acta.*– 1983.– V. 722. P. 381–391.
19. Krasinskaya I. P., Marshansky V. Ya., Dragunova S. F., Jaguzhinsky L. S. Synchronization of respiratory chain enzymes function and ATP – synthase of energized mitochondria. *Biochemistry.*–1984.– Vol. 49.– Issue 1.– P. 87–92.

20. Klingenberg M., Held H. W. The ADP/ATP translocation in mitochondria and its role in intracellular compartmentation. *Metabolic Compartmentation* / Ed. H. Sies. London etc. Ac. Pr.,– 1982.– P. 101–122.
21. Khadjieva B. R. Comparative efficacy of different medicinal drugs of silmarin in the course therapy of alcoholic liver diseases. PhD., dissertation.– Moscow. Russia.– 2009.– 133 p.
22. Dorkina E. G. Hepatoprotective properties of flavonoids (pharmacodynamics perspectives of the clinic study). PhD dissertation. Volgograd. Russia.– 2010.– 296 p.
23. El-Beshbishy H. A. Hepatoprotective effect of Green Tea (*Camellia sinesis*) extract against tamoxifen–induced liver injury in rats // *J. Biochem. Mol. Biol.*– 2005.– Vol. 38.– No. 5.– P. 563–570.
24. Woodman O. L. Meeker W. F., Boujaoude M. Vasorelaxant and antioxidant activity of flavonols and flavones: structure-activity relationship // *J Cardiovasc Pharmacol.*– 2005.– Vol. 46.– No. 3.– P. 302–309.
25. H. van der Woude et al. Consequences of quercetin methylation for its covalent glutathione and DNA adducts formation // *Chem. Biol. Interact.*– 2006.– Vol. 160.– No. 3.– P. 193–203.
26. Chance B., Hollinger G. Succinate–linked pyridine nucleotide reduction in mitochondria // *Federat. Proc.*– 1957.– V. 16.– Pt. 1.– 163 p.
27. Mitchell P., Moyle J. Chemiosmotic hypothesis of oxidative phosphorylation // *Nature.*– London,– 1967.– V. 213 (5072).– P. 137–139.
28. Wikstrom M., Krab K. Respiration-linked H⁺ translocation in mitochondria: stoichiometry and mechanism // *Current topics in bioenergetics.*– 1980.– V. 10.– P. 52–100.
29. Skulachev V. P. Energy accumulation in the cell.– Moscow: Science.– 1969.
30. Kondrashova M. N. Metabolic states of mitochondria and main physiologic states of living tissues // *Properties and functions of macromolecules and macromolecular systems.*– Moscow: Science,– 1969.– P. 135–160.

Section 2. Geography

*Isakova Aziza Yadgarovna,
Trafimov Gennadiy Nikolaevich,
Prof. Dr., National University of Uzbekistan
named after Mirzo Ulugbek,
teacher, of the Faculty of geology and geography,
Tashkent city, Uzbekistan
E-mail: isakovaziza@mail.ru*

ESTIMATION EMPIRIC SUPPLY OF MAXIMUM FLOWS OF MUD FLOODS ON SMALL RIVERS IN UZBEKISTAN

Abstract: The paper deals with the estimation of empirical supply of maximum mudflows recorded on small rivers in Uzbekistan.

Keywords: small rivers, intense rains, mudslides, the maximum cost nanosovodnye mudslides, debris flows repeatability.

Introduction. Calculations of maximum costs are one of the most difficult tasks in the design and construction of various kinds of structures on rivers. Underestimation of maximum costs leads to the destruction of structures, the flooding of coastal areas and often to human casualties. In turn, the overestimation of these highs increases the cost of facilities and reduces their economic efficiency. The problem of calculating maxima is complicated many times, when it comes to mudflows. Let us briefly dwell on the reasons that determine this problem:

1. Litter flows, characterized by large, or better to say, outstanding maximum costs – an objective phenomenon, one can say the necessary in the life of the river;

2. There are no data on the composition of the mudflow mass of “classical” mudflows;

3. In Uzbekistan, so-called “nano-driven mudslides” are formed on small, especially low-mountain rivers. The main reason for the formation of such mudflows is intense rainfall;

4. In the overwhelming majority of cases, the maximum flow of a large flood is characterized as a mudflow, especially if its passage was accompanied by some destruction;

5. Information on the maximum expenditure of mudflows hydrologists receive on the basis of a survey of “traces of mudflows”, which are often not expressed throughout the course of the riverbed, but only in some of its places;

6. There are no information on mudflows for 33.7% of the rivers in Uzbekistan (29.3% for the rivers of the Amu Darya basin and 42.7% for the rivers of the Syr Darya basin). For more than 70% of cases of registered mudflows, it is impossible to determine the place (range) of estimating maxima [9];

7. It is difficult to give a probabilistic estimate of such maxima, since firstly, the series of observations are very short, and secondly, initially, for example, because of paragraphs 4 and 6, the rows are not homogeneous.

Nevertheless, the needs of practice require at least an approximate probabilistic evaluation of such maxima. As can be seen from what has been said above, the only possibility for statistical calculations remains the use of annual maxima recorded at the water station.

Results and its discussion. The maxima of the mudflows, given in the reference materials [10], should be used as a definite reference point, or “background” of the general picture of the mudflow hazard of the watercourse.

For very small rivers with catchment areas 10–20 km², it is possible to include the data of the mudflow catalog and other reference books on maxima, since due to the small extent of the watercourses, the change in the location of the measurement range of this maximum will not have a significant effect on its size.

As is known, the probability of excess (security) of the maximum flow is determined by the type (class) of the structure, its cost, operating conditions, etc. Usually, according to construction standards, the security of maximum costs varies from 0.01 to 1% and, if it is an annual maximum, a series of observations of 100 years or more are required for such an assessment. In the absence of such data it is recommended to use those or other theoretical laws of distribution of variables. In hydrology, the distributions of K. Pearson, S. N. Kritsky, and MF Menkel are used most often, and the distribution of E. Gambel is less often [2, 6, 7].

A large number of papers have been devoted to the conditions for the applicability of a particular theoretical distribution in hydrology. Here I would like to note that very short, according to the concepts of mathematical statistics, series of observations of the maximum annual water discharge and the statistical features of these series in most cases do not give a positive result when using one or another theoretical distribution law. So, SN Kritsky and MF Menkel note that “the points depicting the observed values of the maximum runoff on the availability graph are sometimes deviating significantly from the upper section of the theoretical curve ...” [4].

The formation of outstanding maximum costs is an objective phenomenon caused by a combination of random processes occurring in the river basin. This can be a rain of exceptional intensity, breakthroughs in the dams of high-mountain lakes, sudden movements of glaciers, the descent of landslides and swamps, partition walls of rivers, etc. Therefore, before carrying out statistical calculations, it is necessary to make sure that such situations are possible in the future. For example, on the Isfayramsy River in 1963, with the breakthrough of the dam of the high-altitude lake Yashinkul, an extraordinary maximum of 1770 m³/s was formed. Note that the second maximum in the ranked series was “only” 286 m³/s. In the absence of other such objects in the river basin, the repetition of such maxima is excluded [10].

The basis of statistical calculations and their results is a series of observations. To describe the empirical distribution function and extrapolate these calculations to the region of rare occurrence in hydrology, a number of formulas are used. Most often these are the formulas:

$$- \text{A. Hazena } p = \frac{m-0,5}{n} \cdot 100\%; \quad (1)$$

$$- \text{N. N. Chegodaeva } p = \frac{m-0,3}{n+0,4} \cdot 100\%; \quad (2)$$

$$- \text{S. N. Kritsky-M.F. Menckel } p = \frac{m}{n+1} \cdot 100\%; \quad (3)$$

$$- \text{E. G. Blokhinova } p = \frac{m-0,4}{n+0,2} \cdot 100\%; \quad (4)$$

$$- \text{D. Cowden } p = \frac{1}{\sqrt{n}+1} \left(\frac{m}{\sqrt{n}} + \frac{1}{2} \right) \quad (5)$$

Note that the formula of Kritsky-Menckel completely corresponds to the previously proposed formula of E. Gambel, and the formula of D. Cowden is often called the formula “min / max”. All the above formulas do not take into account either the absolute variations of the original variables or their statistical characteristics. The main arguments in them are the ordinal number of the variable m and the total length of the series n . A detailed analysis of such formulas was made by Yu. B. Vinogradov and MA Mamedov [1, 5].

Unfortunately, in mathematical statistics, methods of probabilistic estimation of “sharply allocated quantities”, which are often called “emissions”, are practically not developed [3]. Mathematicians, mainly interested in the question of excluding such “emissions”, distorting, in their opinion, the statistical characteristics of the series. The procedure for excluding such anomalous values is elaborated in detail. To hydrologists, and especially to practical hydrologists, it is precisely such sharply differing members of the series.

As is known, mathematical statistics use those or other criteria for estimating both the laws of distributions and the characteristics of aggregates. Among these criteria, Irwin's criterion [8] is intended to give an answer to the question of whether the extreme terms of a series of a given set belong:

$$\lambda = \frac{x_i - x_{i+1}}{\sigma_x} \quad (6)$$

where x_i and x_{i+1} are adjacent terms of the ranked series

To calculate empirical security, we have proposed the formula

$$p^* = \frac{mn - \lambda^2}{n(n + \lambda^2)} \quad (7)$$

The verification of this formula on highly asymmetric series of maximum annual water discharge for a number of rivers showed that:

- it is the least biased in comparison with the formulas (1-5);
- with a small difference between the neighboring terms of the series, we practically get an unbiased estimate of the security $p^* = \frac{m}{n}$;
- for sharply asymmetric series, formula (7) gives the smallest variance of estimated p^* ;
- we add that with increasing n the probability of exceeding p^* tends to 1, which indicates its consistency.

To demonstrate the advantages of formula (7) in calculating the empirical abundances of the maxima, we

give the observation data on the Shaugazsai River (left tributary of the Akhangaran River). The catchment area of the river to the water point (Karataş tract) is 65.8 km², the length of the watercourse from its source to the water point is 15 km, the total length of the river is 22 km, the average height of the catchment area is 1.66 km.

There are a number of observations from 1951 to 2004, i.e. somewhat more than 50 years. The maximum water discharge measured at the station was 172 m³/s (July 27, 1964), the smallest annual maximum of 0.55 m³/s, which was observed twice in 1962 and 1977. The average of the maximum costs is 7.46 m³/s. The coefficient of variation of this series is 3.20, and the asymmetry coefficient is 6.61. The results of calculating the empirical security according to the above formulas for the upper part of the curve (the first 10 members of the ranked series) are given in (table 1).

Table 1. – Empirical assurances of the maximum water flow of the river Shaugazsai (without a mudflow maximum)

№	Empirical assurance of maximum water flow								
	$Q_{max} \text{ m}^3/\text{s}$	$\frac{m}{n}$	$\frac{m}{n+1}$	$\frac{m-0,3}{n+0,4}$	$\frac{m-0,5}{n}$	$\frac{m-0,4}{n+0,2}$	$\frac{1}{\sqrt{n+1}}(\frac{m}{\sqrt{n}} + 0.5)$	$\frac{m}{n+1+k_m Z}$	$\frac{mn-\lambda^2}{n(n+\lambda^2)}$
1.	172	0.0189	0.0185	0.0131	0.0094	0.0113	0.0771	0.0017	0.0042
2.	33.5	0.0377	0.0370	0.0318	0.0283	0.0301	0.0937	0.0270	0.0376
3.	24.0	0.0566	0.0556	0.0506	0.0472	0.0489	0.1104	0.0466	0.0565
4.	19.3	0.0755	0.0741	0.0693	0.0660	0.0677	0.127	0.0659	0.0755
5.	17.2	0.0943	0.0926	0.0880	0.0849	0.0865	0.1436	0.0893	0.0941
6.	8.79	0.1132	0.1111	0.1067	0.1038	0.1053	0.1602	0.1083	0.1132
7.	7.58	0.1321	0.1296	0.1255	0.1226	0.1241	0.1768	0.1272	0.1321
8.	6.23	0.1509	0.1481	0.1442	0.1415	0.1429	0.1935	0.1463	0.1509
9.	5.29	0.1698	0.1667	0.1629	0.1604	0.1617	0.2101	0.1651	0.1698
10.	5.09	0.1887	0.1852	0.1816	0.1792	0.1805	0.2267	0.1836	0.1887

Table 2. – Empirical assurances of the maximum water flow of the river Shaugazsai (with a maximum of a maximum)

№	Empirical assurance of maximum water flow								
	$Q_{max} \text{ m}^3/\text{s}$	$\frac{m}{n}$	$\frac{m}{n+1}$	$\frac{m-0,3}{n+0,4}$	$\frac{m-0,5}{n}$	$\frac{m-0,4}{n+0,2}$	$\frac{1}{\sqrt{n+1}}(\frac{m}{\sqrt{n}} + 0.5)$	$\frac{m}{n+1+k_m Z}$	$\frac{mn-\lambda^2}{n(n+\lambda^2)}$
1	2	3	4	5	6	7	8	9	10
1.	274	0.0189	0.0185	0.0131	0.0094	0.0113	0.0771	0.0011	0.0024
2.	33.5	0.0377	0.0370	0.0318	0.0283	0.0301	0.0937	0.0300	0.0377
3.	24.0	0.0566	0.0556	0.0506	0.0472	0.0489	0.1104	0.0495	0.0566
4.	19.3	0.0755	0.0741	0.0693	0.0660	0.0677	0.127	0.0687	0.0755
5.	17.2	0.0943	0.0926	0.0880	0.0849	0.0865	0.1436	0.0872	0.0942
6.	8.79	0.1132	0.1111	0.1067	0.1038	0.1053	0.1602	0.1093	0.1132
7.	7.58	0.1321	0.1296	0.1255	0.1226	0.1241	0.1768	0.1281	0.1321

1	2	3	4	5	6	7	8	9	10
8.	6.23	0.1509	0.1481	0.1442	0.1415	0.1429	0.1935	0.1469	0.1509
9.	5.29	0.1698	0.1667	0.1629	0.1604	0.1617	0.2101	0.1657	0.1698
10.	5.09	0.1887	0.1852	0.1816	0.1792	0.1805	0.2267	0.1842	0.1887

Based on a study of the traces of the catastrophic flood in 1964, the maximum flow was estimated at 274 m³/s for a track located slightly below the water point. Naturally, the statistical characteristics have changed: the average value of the flow is 9,38 m³/s, the coefficients of variation and asymmetry are 4.00 and 7.00, respectively (table 2).

When analyzing the data (tables 1 and 2), it is noteworthy that if the empirical supply is equal to 0,0042 a for the flow rate of 172 m³/s, naturally, the supply security of 274 m³/s is much less and according to formula (7) it is equal to 0,0024, i.e. almost 2 times less. Obviously, formulas (1–5) of such an adjustment can not fulfill the estimation of empirical security.

Obviously, with the above statistical characteristics of the series, the use of the three-parameter distribution of Kritsky-Menckel, traditionally used in hydrology, is impossible and, to compare the empirical assumptions

calculated from formulas (1–7) with the theoretical, we used the distribution of K. Pearson. For illustration, a maximum of 1% of the provision is selected, the results of the calculations are presented in (table 3).

When comparing the maxima calculated from the empirical formulas with their magnitude, obtained from the distribution of K. Pearson, it is clear that the amount of expenditure obtained by the formula “min / max” is unreasonably overestimated. It is understandable to overestimate the highs calculated by the formulas (1–5), because with a decrease in the number of points, the security in the region of its small values inevitably increases. A different picture of the change in the maxima of 1% of security, calculated by the formula (7). We add that on average, the smallest deviation of the empirical peaks from their Pearson value was obtained by the formula (7) – 22.0%.

Table 3. – The maximum water expenditure of 1% of provision, calculated by different formulas (without taking into account the mudflow maximum)

Number of points	Maximum water consumption 1% of supply, m ³ /s								
	According to Pearson	$\frac{m}{n}$	$\frac{m}{n+1}$	$\frac{m-0,3}{n+0,4}$	$\frac{m-0,5}{n}$	$\frac{m-0,4}{n+0,2}$	$\frac{1}{\sqrt{n+1}}(\frac{m}{\sqrt{n}} + 0.5)$	$\frac{m}{n+1+k_m Z}$	$\frac{mn-\lambda^2}{n(n+\lambda^2)}$
53.	120	222	220	180	152	166	740	91,2	120
26.	161	310	306	251	212	232	764	121	138
18.	187	355	348	287	244	266	765	142	143
10.	240	430	418	348	297	323	770	174	120

Table 4. – The maximum water expenditure of 1% of the provision, calculated by different formulas (taking into account the mudflow maximum)

Number of points	Maximum water consumption 1% of supply, m ³ /s								
	According to Pearson	$\frac{m}{n}$	$\frac{m}{n+1}$	$\frac{m-0,3}{n+0,4}$	$\frac{m-0,5}{n}$	$\frac{m-0,4}{n+0,2}$	$\frac{1}{\sqrt{n+1}}(\frac{m}{\sqrt{n}} + 0.5)$	$\frac{m}{n+1+k_m Z}$	$\frac{mn-\lambda^2}{n(n+\lambda^2)}$
53.	186	354	351	351	238	261	938	127	159
26.	255	496	488	399	337	369	1230	178	188
18.	300	568	557	459	389	425	1230	212	199
10.	381	687	668	556	475	516	1230	271	174

Returning to the problem of including, or not including, mudslides in the general long-term series of observations, we refer to the opinion of I. F. Goroshkov [2].

Guided by these considerations, we performed calculations of a maximum of 1% of the availability of the Shaugasai River, taking into account the maximum of 1964, obtained on the basis of hydraulic calculations for

the cross-section of the channel located below the hydrostatic, by about 1.5–2 km. This maximum, as noted above, is estimated by the harvesters at a rate of 274 m³/s [9]. Using a new series of maxima, we repeated the calculation of 1% of the water flow for a different number of terms in the series (table 4).

As can be seen from (tables 3 and 4), the mudslides are higher than the peaks observed at the water station by about 1.4–1.6 times, which is to some extent due to the mismatching of the calculated alignments. The smallest average deviation of the expenditure of 1% of the security compared with the Pearson curve was obtained from the formula (5) – 28.7%. However, according to formula (7), the analogous deviation is 32.3%.

Apparently, we should add that the ratio of the largest 1% maximum (with a small number of terms of the series), to the smallest (at the maximum length of the series), in calculations by formulas (1–4) is approximately 1.9–2.0. This ratio is substantially smaller for formulas (5 and 8), but, as already noted, the calculation by the formula “min / max” greatly overestimates, in comparison with the others, the value of 1% of the maximum, which raises doubts about the expediency of its use in

practical calculations. This conclusion, in our opinion, is important when using short series and it is impossible to supplement these series with any data, for example, using observation materials on the analog rivers.

Conclusions. So, you can summarize the findings:

- an estimate of the empirical supply of maximum costs by formula (7) is the least biased compared to the rest of the biased estimates;
- its small variability speaks of its solvency;
- estimating the maximums in the region of rare frequency of occurrence, as Yu. B. Vinogradov points out, “... it should not be embarrassing that the minimal term of the variational series for any n will have the estimate $p^* = 1$ ” [1];
- the empirical security calculated by formula (7) is least dependent on the number of terms in the series;
- in practical calculations for small rivers, it is expedient to take into account the so-called mudflow peaks, and the use of formula (7) ensures the smallest increase in design values (about 1.3–1.4 times), which, to some extent, prevents justified overestimation of highs and little justified rise in the cost of the designed facilities.

References:

1. Vinogradov Yu. B. Mathematical modeling of flow formation processes. – L.: Gidrometeoizdat, – 1988. – P. 203–251.
2. Goroshkov I. F. Hydrological calculations. – L.: Gidrometeoizdat, – 1979. – P. 214–231.
3. Dlin A. M. Mathematical statistics in engineering. – M.: Science, – 1958. – P. 49–51.
4. Kritsky S. N., Menckel M. F. Hydrological basis of river flow management. – M.: Science, – 1981. – P. 27–77.
5. Mammadov Magbet Adil ogli. Analysis of the conditions of formation and methods for calculating the maximum expenditure of mountain rivers (on the example of the rivers of Transcaucasia and Dagestan). – Author’s abstract. Diss. Doct. geogr. sciences. – L., GGI, – 1984. – 39 p.
6. International guidelines on methods for calculating basic hydrological characteristics. – L.: Gidrometeoizdat, – 1984. – P. 23–63.
7. Manual on the calculation of hydrological characteristics. – L.: Gidrometeoizdat, – 1984. – P. 41–70.
8. Smirnov N. V., Dunin–Barkovsky I. V. Course of the theory of probability and mathematical statistics (for technical applications). – Moscow: Nauka, – 1965. – 510 p.
9. Khald A. “Mathematical Statistics with Technical Applications”. – Moscow: IL, – 1956. – 664 p.
10. Chub V. E., Trofimov G. N., Merkushev A. S. Sulfur flows of Uzbekistan. – Tashkent: Uzgidromet Publishing House, – 2007. – 109 p.

*Reimov M. P.,
Tashkent Institute of Irrigation
and Agricultural Mechanization Engineers, Uzbekistan*

*Húska D.,
Slovak University of Agriculture in Nitra, Slovakia*

*Pulatov A. S.,
Tashkent Institute of Irrigation
and Agricultural Mechanization Engineers, Uzbekistan*

*Certain aspects of Ecosystem Service Analysis
in protected areas (reserves) of Aral Sea region in Uzbekistan*

E-mail:

CERTAIN ASPECTS OF ECOSYSTEM SERVICE ANALYSIS IN PROTECTED AREAS (RESERVES) OF ARAL SEA REGION IN UZBEKISTAN

Abstract: This research aims to analyze ecosystem services in protected areas of Aral Sea region. In this research were taken two protected areas which are situated in Aral Sea region: “The Complex (landscape) Reserve SAYGACHI” and the “Lower Amudarya State Biosphere Reserves in Uzbekistan”.

These protected areas aims to protect and restore landscapes, flora and fauna of tugai forests, including their rare species, to improve ecological condition and sustainably use natural resources and to study natural processes, and promote environmental education, training and awareness. The ecosystems in these protected areas provide different ecosystem services to different stakeholders. Nowadays the ecosystem services of these areas is not fully studied and no information exist on zones. Moreover, nowadays these protected areas are on the verge of disaster. This primarily is due to the increase of water scarcity in the lower part of Amudarya river leads to degradation of tugai forests and biodiversity, increase of desertification and salinity of the territory. In this article there are four different types of ecosystem services are identified and analyzed by existing different zones of the “Complex (landscape) Reserve SAYGACHI” and the “Lower Amudarya State Biosphere Reserves in Uzbekistan”.

Keywords: Aral Sea, Protected areas, landscape reserve, biosphere reserve, ecosystem, ecosystem services, types of ecosystem services, provisioning service, regulating service, habitat service, cultural service, economic zone, buffer zone, protected zone and farming zone.

Introduction

The Complex (landscape) Reserve “SAYGACHI” was re-established in 2016 in the Karakalpak Autonomous Republic, in Uzbekistan. The total area is 628300 ha within these the protected zone of the reserve consists 219800 ha Resolution [7]. The reserve is located on the territory of Muynak and Kungirat districts (See table 1).

The main objective of the reserve is preservation in a natural state of natural objects and complexes having a

special ecological value in the territory. The main task of reserve area, Preservation in a natural state of all natural objects and complexes on the territory; Promotion of scientific research and monitoring of the natural environment, training of scientific personnel and specialists in the field of environmental protection, Provision of biological and landscape diversity, maintenance of ecological balance in the protected area system (ecological network) of the Republic of Uzbekistan.

On the territory of the complex reserve is allowed: Implementation of scientific research activities; Implementation of recreational activities; Monitoring the biodiversity; Construction of buildings for employee of the reserve and scientists; Accommodation of nature museums including expositions in the open air.

The following sites are allocated on the territory of the complex reserve:

- The content of working horses of the complex reserve and other similar purposes;
- Mowing and grazing, harvesting (collection) of wild plants for food purposes, wild plant medicinal and technical raw materials for citizens living in its protection zone in accordance with the procedure established by law;
- Provision of official land allotments to employees of the complex reserve and at the time of retirement and dismissal of employees of the complex reserve the right to use the official plot ends.
- The total area allocated (provided) for the above-mentioned lands is determined on the basis of the minimum required area for pasturing cattle, taking into account the rotation of pastures, harvesting of plants and mowing.
- These lands should be located along the boundaries of the complex reserve and not exceed 0.001% of its area. The area and boundaries of these lands are determined when preparing the management plan and are included in it by the director together with the Advisory Commission.

In the protected zone of the Complex (landscape) Reserve SAYGACHI is carried out:

- Prevention and reduction of any negative impact on protected natural sites and complexes of a complex reserve;
- Improvement of living conditions and migration of animals due to the provision of communication between the individual sites of the complex reserve, protection, reproduction and restoration of which cannot give the proper effect only on the territory of the complex reserve;
- Carrying out of biotechnical actions for species of plants and animals protected in a complex reserve.

In the territory of the protection zone, the following activities are carried out in agreement with the complex reserve: Travel on roads; Carrying out of repair work on the communications located in the protected zone; Ecological tourism, creation of buildings and facilities for servicing tourists; Geological exploration; Haymaking in limited quantities; Grazing of cattle; Use of plants and animals without withdrawal from the environment of growth or habitat; The biotechnical activities are carried out in accordance with the management plan of the complex reserve.

In the protected zone, the following types of economic and other activities are limited in order to prevent and reduce the negative impact on natural sites and complexes of the complex reserve: Mining; Construction of gas pipelines, other communications, facilities for processing raw materials and other industrial facilities; Laying new roads.

In the protection zone, it is prohibited: Hunting and trapping of animals, collection of plants, except for cases provided for in the management plan; Application usage of pesticides.

Table 1. – Areas of land plots provided to the Complex (landscape) Reserve “SAYGACHI” for permanent use (Resolution, No. 238.–2016)

Name of the area	Allocated land	Types of land	Area, ha
Muynak district, Republic of Karakalpakstan;	Reserve lands	Other lands, not used in agricultural purposes	31200.0
Kungirat district, Republic of Karakalpakstan.	Reserve lands	Other lands, not used in agricultural purposes	597100.0
Total allocated land	–	–	628300.0

The Badai-Tugai nature reserve was founded in 1971 in the Karakalpak Autonomous Republic in Uzbekistan. The area is 6462 ha, the nature reserve is located in the lower Amudarya river, on the territory of

Beruni and Amudarya districts, on the right bank of the river. The aim of the nature reserve is to conserve tugai ecosystems and protect Bukharian deer. The deer population in the reserve and its adjoining territories

increased to more than 300 individuals since its creation Baxieva [1]. In 2011 the Cabinet Ministers of the Republic of Uzbekistan decided to accept the proposal of the Council of Ministers of the Republic of Karakalpakstan and the Ministry of Agriculture and Water Resources to transform the Badai-Tugai nature reserve into Lower Amudarya State Biosphere Reserve (LASBR) by increasing its territory from 6462 till 68718 hectares Resolution [8]. The new aim of Lower Amudarya Biosphere Reserve is to preserve and restore landscapes, flora and fauna of Tugai forests, including their rare and extinction species, improve ecological condition and provide sustainable use of natural resources and study of natural processes, and promote environmental education, training and awareness. In order to realize the aims and tasks of the biosphere reserve, the territory is divided into three zones: protection, buffer and transitional (economic) zones. The protection zone is composed of 11568 hectare (17%) and it is under strict protection regime. This zone is for protecting natural objects and complexes, for conducting monitoring and scientific research. The Buffer zone consists of 6734 hectare (10%) and is for protection and restoration of natural objects and complexes. The regime is set according to the law. The land of Buffer Zone is in possession of renters. The Transitional (Economic) zone consists of 50418 hectare (73%) and is formed for realization of household and other activities without damaging the natural objects and complex. Transitional reserves land is also in possession of land users and renters Resolution [8].

Ecosystem services are the benefits people receive from ecosystems MA [6]. The identifying and quantifying ecosystem services is highly recognized as an important tool of resourceful provision of environmental resources Heal [3].

The Complex (landscape) Reserve “SAYGACHI”: There are mainly terrestrial type of ecosystems are developed in the area, such as grasslands and deserts. The ecosystem in the reserve provides some ecosystem services to some stakeholders. There are main two types of Ecosystem services which exist in the area. Habitat services are more important for flora and fauna of the reserve as one of the main task of the area is protecting the and saving the biodiversity. The second service which provides by the reserve is cultural services.

The Lower Amudarya State Biosphere Reserve:

There are terrestrial and aquatic types of ecosystems are developed in the area, such as tugais, forests, grasslands, croplands and river. It provides different ecosystem services to different stakeholders. There are main four types of Ecosystem services which exist in the area. Provisioning services are more important for adjacent areas near the protected territory (buffer and economic zone) of the studied area for human consumption, such as: agricultural products and food (cotton and wheat) and construction materials (small building stones and building limestone). Regulating services relate to the capacity of natural and semi-natural ecosystems to regulate essential ecological processes and life support systems through biogeochemical cycles and other biosphere processes. These regulation services have direct and indirect benefits to humans (such as clean air and biological control services). While the provisioning and regulation services are valuable, but for the Badai-Tugai forest and other riparian forest areas more important are the habitat services, when natural ecosystems provide reproduction habitat to plants and wild animals, due to its geo ecological uniqueness as a site for the biodiversity conservation. Moreover, besides all above mentioned ecosystem services, this area provides cultural services.

Problem Statement

Nowadays these protected areas (reserves) are on the verge of disaster. This most probably due to the increase of water scarcity in the lower part of Amudarya river, which leads to termination of tugai forests and biodiversity, increase of desertification and salinity of the territory. At present time on these reserves has low level of ecosystem service analysis and it makes difficulties in their prioritization for their protection and management in order to accordingly reduce the negative impact.

This can be done through analysis of ecosystem services which can construct a base for their future quantification the existing services and identification of priority services need to be protected and managed.

The **main goal** of the paper is identification and quantification of ecosystem services at the Complex (landscape) Reserve “SAYGACHI” and Lower Amudarya State Biosphere Reserve.

Material and methodology

Ecosystem Service Analysis

The ecosystem services are well-defined in the Millennium Ecosystem Assessment as: “the benefits supplied

by ecosystems to society” MA [6]. The ecosystem services classification system that was used is derived from The Economics of Ecosystems and Biodiversity (TEEB) not the Millennium Ecosystem Assessment (MA). The main reason is that TEEB omits supporting services, for which it is not clear what exact benefits people obtain from supporting services in these protected areas which are explained above. Three main types of terrestrial ecosystems (tugais, grasslands and desert) were analyzed and two main types of ecosystem, services including: habitat (flora and fauna) and cultural (ecotourism) in developing process analyzed at Complex (landscape) Reserve SAYGACHI while there are five main types of ecosystems (tugais, forests, grasslands, croplands and river) were analyzed and four main types of ecosystem services including: provisioning (cotton, wheat, building limestone) service, regulating (pest control, carbon sequestration) service, cultural (eco-tourism) service and habitat (flora and fauna) service at Lower Amudarya State Biosphere Reserve.

Data collection and analysis tools

In this research following methods such as literature review, questionnaires, interviews and observations were used. Each of these data collection tools is linked to one of the methodologies to address research question (see Table 2). The description of each tool and the process of its use are presented in the sections below.

Literature Review

Literature review is mainly used to collect data on the following topics.

Firstly, the data on existing location, area, functions and structures of the Complex (landscape) Reserve SAYGACHI from the State Committee of the Republic of Uzbekistan on Nature Protection (SCRUNP) and State Committee of Uzbekistan on Land Resources, Geodesy, Cartography and State Cadaster (STCURGCSC).

Secondly, basic data about fauna and flora on the recommendations on the expansion of protected areas in Uzbekistan “justification for the creation of a protected areas of northern Ustyurt” which prepared by United Nations Development Program (UNDP) and Global Ecology Fund (GEF).

Thirdly, the data about the existing quantity, names and location of farms, massives and existing quarries, which are situated in economic and buffer zones of the Lower Amudarya State Biosphere Reserve territory were

obtained from the State Committee of Uzbekistan on Land Resources, Geodesy, Cartography and State Cadaster (STCURGCSC) for the year 2016 data.

Fourthly, types of crops and annual productivity of above mentioned farms and types of products and its annual productivity of quarries were obtained from the Government authorities (Amudarya and Beruni municipalities) and the State Committee of Republic of Uzbekistan on Statistics (SCRUS) respectively for the year 2016 data.

Lastly, data about the exact index of Pest control methods to use for massives who are situated in Economic and Buffer zone was obtained from the plant protection department of the Ministry of Agriculture and Water Resources of the Republic of Uzbekistan (MAWRRU) for the year 2016. In addition, the data about Carbon sequestration, types of existing habitat services (nursery, flora and fauna) and population of Bukharan deer were obtained from the UNDP/GEF Project “Conservation of Tugai Forest and Strengthening Protection Areas System in Amu Darya Delta of Karakalpakstan” archives. Finally, the literature on the current condition of cultural service (ecotourism) of Lower Amudarya State Biosphere Reserve was reviewed.

Questionnaire and Interviews

In this research the structured and unstructured interview questions and open and close ended questions were used. The questionnaire and interview data collection tools were implemented for research question.

Firstly, to investigate the current existing ecosystem services and annual number of tourists in the Lower Amudarya State Biosphere Reserve the oral interviews were organized with two employees of the Lower Amudarya Biosphere Reserve. Secondly, in order to find out the personal information about the size of the territories, the soil bonitet (The term “bonitet” refers to the integrated soil productivity assessment scale. This term is frequently used in Central Asian countries. The bonitet is assess on the scale from 0 (minimum) to 100 (maximum). The soil valued at 100 points gives the highest yield and is usually found at a place not affected by soil erosion. Gray forest soils get 60–80 points, brown and mountain soils get between 30–60 points. It allows us to give fairly accurate prediction of crop yields. Soil bonitet is taken into account while determining value of the land, when it is sold,

determining the taxes and annual rent payment) annual yield amount, types of harvested products, types of fertilizers, methods of pest control, random sampling design and cluster types were selected, because there took into account farmers' geographic location and divided into some groups Kumar [4]. There are total ten farmers who are situated close to protected zone of the LASBR from ("Berdakh", "Qipchak", "Biybazar" and "Beruniy" massives) were surveyed.

Observation

The observation objects are divided according to the different ecosystem services. For the provisioning services, types of agricultural products and foods (cotton and wheat) and construction products (Small building stone and Building limestone) were observed. For the habitat service the presence of different gene pool protection services and nursery services were observed in the protected areas.

Table 2. – Summary of Methodology

Research Questions:	Research Methods:	Data Collection and Analysis tool:
What ecosystem services are provided by the Complex (landscape) Reserve "SAYGACHI"?	Ecosystem Service Analysis	Literature review Observation
What ecosystem services are provided by Lower Amudarya State Biosphere Reserve?	Ecosystem Service Analysis	Literature review Observation Questionnaires and Interview

Results:

Ecosystem Services in the Complex (landscape) Reserve SAYGACHI

As a result of data collection methods there were main two types of ecosystem services in area identified, there are habitat (flora and fauna) services and cultural (ecotourism).

Ecosystem Services in the Lower Amudarya State Biosphere Reserve

The ecosystem in the Lower Amudarya State Biosphere Reserve provides different services to different stakeholders. As the result of data collection methods there were identified main four types of ecosystem services in the area, there are provisioning (cotton, wheat, small building stone and building limestone) services, regulating (carbon sequestration) service, habitat (gene pool protection service and nursery) and cultural (ecotourism).

Provisioning services

Provisioning services are ecosystem services that describe products that can be extracted or harvested in ecosystems Samper [10].

According to the primary data analysis there were no provisioning service were identified in the Complex (landscape) Reserve SAYGACHI while Lower Amudarya State Biosphere Reserve provides mainly of food and construction products. The production of food includes agriculture activities as crops (cotton and wheat) growing production. The construction products

include building stones and limestone production. These construction products are used in construction industry. The main stakeholders of these services are farmers and industries that make direct benefit from these products.

Agricultural products and Foods (Cotton and Wheat)

The most important provisioning service of Lower Amudarya State Biosphere Reserve is the production of food. There are mainly two types of agriculture products harvested in farming zone 30728 ha (splits up economic and buffer zone) of the Biosphere Reserve: cotton and wheat.

As the result of analyzing the data from the Ministry of Agriculture and Water Resources of the Republic of Uzbekistan and the State Committee of the Republic of the Uzbekistan on Land Resources, Geodesy, Cartography and State Cadastre in total around twenty thousand tons of cotton (around 0.5t/ha/y) and around three thousand tons of wheat (0.1t/ha/y) are harvested annually from farming zone of the Lower Amudarya State Biosphere Reserve.

Construction products (Small building stone and Building limestone)

The second most important provisioning service of Lower Amudarya State Biosphere Reserve is the annual production of Construction products. There are mainly two types of construction products harvested in economic zone of the Lower Amudarya State Biosphere

Reserve: small building stones and building limestone. About 60 thousand cubic meter (1.2 m³/ha/year) of small building stones and 1.5 thousand tons (0.03t/ha/year) of building limestone are harvested by three Limited Liability Small Rock Stone Construction companies and one Limited Liability Limestone Company respectively in Amudarya district part of the Lower Amudarya State Biosphere Reserve.

Regulating service

Regulating services in the economic and buffer zone of the Lower Amudarya State Biosphere Reserve include pest control services. Pest control service is also one of the important services of Lower Amudarya State Biosphere Reserve to sustain plant (provisioning service) growth and functioning of the ecosystem. Nowadays two types of pest control services exist in the area. There are main biological and getting decrease chemical method are using in the area. Three types (Trichogramma, Braccon and Oltinkoz) of biological method of pest control services are used for agricultural products and foods in all massives in the farming zone of the Lower Amudarya State Biosphere Reserve because this method is environmental friendly and economically effective.

Habitat Services

Flora of the Complex (landscape) Reserve Saygachi represented by terrastial type of ecosystems such as grasslands and deserts. There are the following main types of plants which are listed in the Red book of Uzbekistan (2009) *Salsola chiwensis*, *Euphorbia scleroscyanthum* and *Halaxylon*, *Tamarix*, *Salsola arbuscula*, *Artemisia*.

Flora of Lower Amudarya State Biosphere Reserve represented by Tugai forest. Tugai is the Turkic word for a floodplain forest in the desert regions of Middle and Central Asia. Tugai can consist of herbaceous shrubs, wood or their combination. Tugais in Lower Amudarya State Biosphere Reserve belong to such kind of tugai which stated above. Riparian plants in Lower Amudarya State Biosphere Reserve begin to bloom after spring flood spills, they scatter seeds. Seeds falling to soil, washed and covered with salt from river sediments, quickly start to grow.

As a result of this Lower Amudarya State Biosphere Reserve has rich biodiversity of plants: there are six types of typical trees: Jida (Jew)-1 type, Willow-2 types, Turanga-3 types. Jida (Jew) is an ancient plant that emerged in the tropical conditions as evergreen. Jew's fruit is widely

consumed by the local population as food. Jew is also known for its medicinal properties, with intestinal disorders, especially in children, the Jew is an indispensable and the most common treatment option.

Turanga or Willow is the relict plant and is unique in many ways because during the extreme heat weather or drought most of the plants dramatically slow down, but the Turanga is always active. It is because the stomata (which water evaporates from the plant into the air and which plant ingests carbon dioxide from atmosphere) are located on both sides of the leaf and tree breathing all time and a huge root system continuously gives water to the leaves.

Fauna of the Complex (landscape) Reserve Saygachi

The reserve provides habitat for 7 species of mammals, 11 birds, 7 reptiles UNDP/GEF [13].

The main pride of the reserve is Saiga (*Saiga tatarica*), Jeyran (*Gazella subgutturosa*) are listed as endangered in the Red List of the International Union for Conservation of Nature and all modern red book of countries of Central Asia. At present time Saigas are under threat for several reasons; they are increasingly hunted for their meat and valuable horns, which are believed to have medicinal purposes. Oil and gas exploration and transportation as well as the laying of new road and rail infrastructures are hindering saiga migrations and impeding access to traditional pastures, many of which are being threatened by increasing livestock numbers (Saiga Conservation 2017).

Moreover there are long-lived hedgehog (*Hemiechinus hypomelas*), turkmen karakal (*Lynx caracal*), white-tailed eagle (*Haliaeetus albicilla*), black griffon (*Aegypius monachus*), snake (*Circaetus gallicus*), eagle (*Aquila heliaca*), steppe eagle (*Aquila nipalensis*), golden eagle (*Aquila chrysaetos*), bustard beauty (*Chlamydotis undulata*), bustard (*Otis tarda*), gray monitor (*Varanus griseus*), Central Asian turtles (*Agriemys horsfieldi*) habitats in the area. Furthermore, there identified the following types of rodents identified which are not inhabiting in other regions of Uzbekistan such as, small gopher (*Spermophilus pygmaeus*), big jerboa (*Allactaga major*), thick-tailed jerboa (*Pygerethmus platyurus*), german (*Stylodipus telum*), jerbao (*Allactaga sibirica*).

Fauna of the Lower Amudarya State Biosphere Reserve

Birds

Lower Amudarya State Biosphere Reserve provides habitat for about 95 bird species Lim [5]. In the character

of staying in Bio Reserve they are distributed as follows: nesting birds-40, sedentary-19, wintering-18 and migratory-18 Lim [5].

Some species of birds are listed in the Red Book of Uzbekistan. These include Pygmy Cormorant, Serpent eagle, brown dove, falcon, peregrine falcon and pheasant. Many species of birds in early spring stop for a brief stay in Lower Amudarya State Biosphere Reserve, during the flight to the northern part of Uzbekistan. Beauty of the bio reserve is certainly the Khiva pheasant. It leads a sedentary life and is ubiquitous. Lower Amudarya State Biosphere Reserve organization contributed to the rapid increase in the number of the Khiva pheasant. Its territory considered to host four to five thousands of these birds. In winter the pheasants concentrate in riparian woodlands, spring, summer and autumn in croplands UNDP [11].

Mammals

The Lower Amudarya State Biosphere Reserve provides habitat for eight predator species: jackals, foxes, weasels, wild chorus, peregusna, badger, steppe cat and jungle cat. In addition, sometimes wolfs were observed in the Lower Amudarya State Biosphere Reserve. One of main prides of the Lower Amudarya Bio Reserve is acclimated Bukharan deer. The Bukharan deer are listed as endangered in the Red List of the International Union for Conservation of Nature and all modern red book of countries of Central Asia. The measures to save the Bukharan deer have been initiated since 1970. As a result of these measures the population of Bukharan deer has been increasing year by year (Chikin, 2007). Nowadays, the Lower Amudarya State Biosphere Reserve has two sites where the Bukharan deer live: one is in the protected zone and the second is in the Buffer zone. The basic food of Bukharan deer are leaves, stems, branches of plants and trees (cane, reed, licorice, erianthus and willow) Lim [5].

The site number 1 is located on the right bank of the Amudarya river and the first section includes the territory of the former Badai Tugai reserve and Tugai Tallik, there were built aviary size eight hectare. The site number 2 is located on the left bank of the Amudarya river from the border with the Khorezm province down to the river till Mangit district and the second site includes the territory of the former Amudarya Kipchak forestry department. Moreover, according to the latest observa-

tion data of the UNDP/GEF Project, 696 and 2 heads of deer were observed in site number 1 and 2 respectively in 2010 UNDP [11].

Fishes

The length of the riverbed along the Lower Amudarya State Biosphere Reserve is 18 km. It provides habitat service to more than 50 species of fish including large Amudarya barbel, bream, saber fish, carp, pike, perch, chub, silver carp, rudd, Aral chipper, Amudarya char Lim [5].

Nursery Service

The Lower Amudarya State Biosphere Reserve is a suitable space for the wild animal and plants. Considering this, Lower Amudarya State Biosphere Reserve also can function as a Nursery for several types of species: Bukharan deer, birds, fishes and three types of typical trees (Jida, Willow and Turanga) in protected zone, buffer zone and Amudarya River.

Cultural Services

Cultural services are defined as non-material benefits received from ecosystems. Nowadays, in these reserves only ecotourism exists as a type of cultural service. Ecotourism is one of the forms of recreation that involves visiting natural places and environment in the world. Nowadays visiting nature reserve areas has been becoming a major attraction by tourists. As a result of this several evaluations have already undertaken on the eco-tourism assessment.

Ecotourism in these reserves will help to increase the protection by providing economic options to people who are living in this area, by creating some information about the economic and natural value of Bio Reserve. The main purpose of ecotourism is to increase the rate of tourism through preservation and environmental conservation. Moreover, it can be said that, by improving the recreation in the reserves, economy of the area will increase in several ways (Transportation communication and etc.) Thus an increase in ecotourism will stimulate economic development and provide economic motivation for preservation of natural areas.

The Complex (landscape) Reserve SAYGACHI:

Ecotourism of reserve is aimed to analyze the feasibility of capturing the available tourist market, to provide a source of funding for the the Complex (landscape) Reserve SAYGACHI and benefits for local communities. The ecotourism in the area is under development.

Lower Amudarya State Biosphere Reserve: Eco-tourism of Lower Amudarya State Biosphere Reserve is subcomponent of the UNDP-GEF project began in 2007 and has aimed to analyze the feasibility of capturing the available tourist market, to provide a source of funding for the Lower Amudarya State Biosphere Reserve and benefits for local communities. Initial survey by the Tashkent-based travel company, OrexCA, came to the conclusion that the the Lower Amudarya State Biosphere Reserve will not have sufficient capacity to support its own tourism business because of inappropriate standard conditions such as tourist path ways, set places to visit tourists and etc. Lim [5].

As a result of these, nowadays any tourism initiatives temporary stopped in the area. The local government took this advice on board and is trying to create a tourism product and encourage local people to develop services based on an integrated tourism throughout from Khorezm to the Aral Sea. At the same time, the government (Forestry Department of the Ministry of Agriculture and Water Resources of Uzbekistan and Amudarya and Beruni districts Municipal governments) is trying to create special pathways which tourists can visit not effecting to nature and conditions that response to international standards.

Table 3.– Type ecosystem services in merited zones

Protected Areas (Reserves)	Services Zones	Provisioning Services				Regulating Services		Habitat Services			Cultural Services
		Cotton	Wheat	Building Limestone	Small rock Stones	Carbon Sequestration	Pest Control	Nursery	Flora	Fauna	Ecotourism
Complex (Landscape) Reserve "Saygachi"	Protected Zone (219000 ha)	-	-	-	-	?	-	+	+	+	+
	Whole area of the Reserve (628300 ha)	-	-	-	-	?	-	+	+	+	+
Lower Amudarya State Biosphere Reserve	Settlement and Economic Zone (50418 ha)	-	-	+(around 0.03 t/ha/y)	+(around 1.2 m ³ /ha/y)	-	-	?	?	?	*
	Buffer Zone (6734 ha)	-	-	-	-	?	-	+	+	+	*
	Farming Zone (Including Economic and Buffer zones)(30728 ha)	+(annually around 0.5t/ha/y)	+(annually around 0.1t/ha/y)	-	-	-	0	?	?	?	-
	Protected Zone (11568 ha)	-	-	-	-	+	-	+	+	+	*
	Amu Darya River	-	-	-	-	-	-	?	+	+	-

Legend: + Provided services by;

- Not provide services;

? Not determined yet;

* Services provided previously (not providing at present time);

0 Using the services.

Discussion

For this research, total three data collection methods were used: literature review, questionnaire and interview and observation. The primary data collection was based

on survey and interviews of different stakeholders related to reserves. The aim of using this data collection method was to identify current existing types of ecosystem services in the area.

More uncertainties and limitations such as the absence of exact data availability for all ecosystem services, absence of data availability about types and annual harvest of existing provisioning services were faced during the data collection process. However the State Committee of Uzbekistan on Land Resources, Geodesy, Cartography and State Cadaster (STCURGCSC) was able to fulfill these missing necessary points in data collection.

In the regulating service there was a data deficiencies in the annual indirect value of regulative (carbon sequestration services) in the area, according to some literature the assumption made that one ha of forest in one hour consumes about eight kg of carbon dioxide. This statement has a small influence on the results, if the assumption changes the amount of carbon dioxide will change, but the nevertheless the process of consumption still exist.

The UNDP project proposed some kind of provisioning, regulating and cultural service of Lower Amudarya State Biosphere Reserve for the future perspectives. The mechanisms for additional financial resources were introduced by the project. There are: resource use fees and tourism charges, bio prospecting fees, payments for environmental services, carbon offsets, biodiversity offsets. Some mechanisms were even introduced for financial and economic incentives for local communities in the Economic/Transition and Buffer Zones: community revenue-sharing, sustainable employment and income, investment and credit funds, eco-labelling and certification, awards, prizes and recognition of good conservation practice [12].

Moreover, the differences in both research are in division of the territory of the reserve into zones. UNDP project made three zones (Economic, Transition and Buffer zones) and in this study four zones were mentioned by adding farming zone inside economic zone and Amudarya river has added (Economic, Farming, Buffer, Protected zones and Amudarya river), which makes the analysis more descriptive and concrete. Finally the results of quantity value of Ecosystem services were sum up in this research.

The research of Treshkin (2000) was done in the sphere of flora, fauna and Tugay forest assessment. They provide information of qualitative and quantitative amount of biodiversity in Baday-Tugay Reserve. According to their analysis the Tugay forest is decreasing and

even can be extinct as the water of Amudarya river will decrease. They also state that the conditions for Tugay forest development are not sufficient and the feeding base of Bukhara deer is disrupted. According our observations the population of Bukhara deer is increasing and their number has reached sufficient level.

Conclusions

Identification and quantification of current existing ecosystem services

With the help of ecosystem service analysis in the Complex (Landscape) Reserve SAYGACHI and the Lower Amudarya State Biosphere Reserve were identified types, annual productivity of current existing four types of ecosystem services of respectively provisioning, regulative, habitat and cultural services in different zones of the reserves.

a) Provisioning Services

There were no provisioning services identified/analysed in the Complex (landscape) Reserve SAYGACHI while the most important provisioning services of Lower Amudarya State Biosphere Reserve are foods (cotton and wheat) and construction products (small building stones and building limestone) by located eight massives (farming zone) and quarries (settlement and economic zone).

There are around twenty thousand tons of cotton (0.5t/ha/y) and around three thousand tons of wheat (0.1t/ha/y) are annually harvested from new created farming zone (splitting up economic and buffer zone of the reserve).

There are around 60 thousand cubic meter of small building stone (1.2m³/h/y) and around 1.5 thousand tons of building limestone (0.03t/h/y) annually harvested from settlement and economic zone of Lower Amudarya State Biosphere Reserve annually.

b) Habitat Services

The Complex (landscape) Reserve SAYGACHI provides habitat for 7 species of mammals, 11 birds, 7 reptiles while Lower Amudarya State Biosphere Reserve is a suitable place for the wild animals and plants. Considering this, Habitat services identified from Lower Amudarya State Biosphere Reserve are gene pool and nursery services for eight species of Mammals 50 fish and 95 bird species in protected zone, buffer zone and Amudarya River.

c) Cultural Services

The cultural services identified only ecotourism services in the area. But at present time in the reserves do not have sufficient capacity to support its own tour-

ism business because of some appropriate standard conditions such as tourist path ways, set places to visit tourists and etc.

References:

1. Baxieva A. Monitoring of riparian ecosystems of Baday-Tugai nature reserve. Paper presented at the Materials of science and practical conference which is dedicated problems biodiversity in protected areas of Uzbekistan, Nukus. – 2008.
2. Chikin Y. Prospects for reintroduction of Bukharan deer in South Aral. Paper presented at the Materials of science and practical conference which is dedicated problems biodiversity in protected areas of Uzbekistan (in Russian), Nukus. – 2007.
3. Heal B. Valuing Ecosystem Services: Toward Better Environmental Decision-making. National Research Council, Washington D. C. – 2005.
4. Kumar R. Research Methodology. A Step-By-Step Guide for Beginners. Sage Publications Ltd, – London. – 2012.
5. Lim V, AN. E. Reserves and national parks (Alikhanov Ed.). – Tashkent: Chinor. – 2007
6. MA. Ecosystems and human well-being. Synthesis. Washington, DC: Island Press. – 2005.
7. Resolution. (N212–2008). On program of actions on Environment Protection of the Republic of Uzbekistan for – 2008–2012.
8. Resolution. (N405–2002). About responsibilities of the State Committee for Nature Protection of the Republic of Uzbekistan in LASBR territory.
9. Resolution. (N238–2016). “On measures to streamline issues related to the creation and organization of complex (landscape) reserve”.
10. Samper. The millenium ecosystem assessment: Science and Policy for sustainable development. Bioscience, 53(12), – 2003. – 1148 p.
11. UNDP. Baday-Tugay reserve and preservation of tugay forests of Karakalpakstan. – 2010.
12. UNDP. (2012). Terminal Evaluation Report. Retrieved Uzbekistan, from: URL: http://www.thegef.org/gef/sites/thegef.org/files/gef_prj_docs/GEFProjectDocuments/M&E/TE/FY2012/UNDP/G001036/1036_2109_Uzbekistan_BD_TE.pdf
13. UNDP/GEF. (2013). Recommendations on the expansion of protected areas in Uzbekistan. – Tashkent: BAKTRIA PRESS.

*Turgunov Daniyar Mannapjanovich,
Khikmatov Fazliddin Khikmatovich,
Prof. Dr., National University of Uzbekistan
named after Mirzo Ulugbek,
lecturer, of the Faculty of geology and geography,
Tashkent city, Uzbekistan
E-mail: d.turgunov1987@gmail.com*

ESTIMATION OF THE LOW-WATER NORM IN THE MOUNTAIN RIVERS OF CENTRAL ASIA

Abstract: The article considers the issues of calculation of the flow norm for the basins of Syrdarya and Amudarya mountain rivers. The low-water years and norms for the low-water years are determined for these rivers. For the first time the notion of “low-water factor” was introduced, and its values were estimated for different types of the river alimentation. The formula for calculation of the low-water norm is proposed.

Keywords: river, catchment area, river flow, flow norm, low-water years, catastrophic low-water years, low-water, low-water factor, low-water norm, Schults’ factor, low-water estimation.

Introduction. As it is known, the river flow is characterized with internal variability. Alternation of the high-water and low-water years can be observed on the rivers. These changes are related to climate factors and are not subjected to the certain regularities. However, the river flow values vary within certain mean value – flow norm. Regarding interannual variability it can be noted that the values of variation frequency are different. According to studies of I. P. Druzhinin, G. P. Kalinin and D. Ya. Ratkovich, it was concluded that the periods of the river flow changes are characterized with 2–3, 5–7, 10–12, 22–28 – year frequency [7].

For the solution of numerous theoretical and applied problems related to the river flow use, the proper estimation of the river flow norm is very important. Thus, on the base of calculated value of the river flow norm it is possible to distinguish the low-water years recorded on the rivers and to calculate the low-water norm for these years. The low-water norms calculated in this way will make the estimation of the water safety degree for the recorded low-water years possible, which facilitates the rational use of the river flow. Problem of the estimation of the water safety degree of the years is one of the less studied problems in hydrology. Basing on the above mentioned, it can be concluded that the estimation of the low-water norm on the rivers is the *main purpose* of this study.

Data. For reaching this goal, 39 mountain rivers on the territory of Central Asia were selected. The data on the mean monthly and mean yearly flow values were collected at hydrological gauging stations with the natural hydrological regime.

Results and discussion. Basing on data of the mean monthly flow values the factors of V. L. Schults (δ) were calculated, and rivers were distinguished by four types of river alimentation sources: 1) glacial-and-snow ($\delta \geq 1,0$); 2) snow-and-glacial ($0,99 \geq \delta \geq 0,26$); 3) snow ($0,25 \geq \delta \geq 0,18$) and 4) snow-and-rain ($0,17 \geq \delta \geq 0,001$) ones (Table 1).

Regarding the main goal of this study, the mean long-term flow values (Q_{me}^l) in the low-water years for the studied rivers were calculated with the following formula:

$$Q_{me}^l = \frac{\sum_{i=1}^n Q_{low}}{n}, \quad (1)$$

where: $\sum_{i=1}^n Q_{low}$ – sum of the mean yearly flow values recorded in low-water years; n – number of the low-water years [5].

For the definition of the low-water years the modular ratios of the mean yearly flow values [4] were used. Their values were calculated with the following formula:

$$K_i = \frac{Q_i}{Q_o}, \quad (2)$$

where: Q_i – mean yearly flow values, m^3/s ; Q_o – flow norm, m^3/s .

As it follows from the formula given above, if $K_i < 1$, then the river flow in the given year is less than the norm and, on the contrary, if $K_i > 1$, then the given year is expected to be high-water one. It should be noted that with the values of the modular ratios in the range of $0.93 \leq K_i \leq 1.07$ it is assumed that the flow value is near the norm. That is why, for singling out the low-water

years as criteria, the modular ratio values were used $K_i \leq 0.92$ [2, 3, 5].

Mean yearly flow values (Q_{me}^l) for the revealed low-water years, as well as the values of the flow norms (Q_o) for the long-term period were calculated for the studied rivers. Calculated values of Q_{me}^l and Q_o made it possible to calculate low-water factor (K_o) as their correlation (Table 1).

Table 1. – Mean long-term values of the low-water factor (K_o) for mountain rivers

Point №	River-station	F, km ²	Q, m ³ /s	$\delta = \frac{W_{VII-IX}}{W_{III-VI}}$	$K_o = \frac{Q_{me}^l}{Q_o}$
1	2	3	4	5	6
<i>Rivers with glacial-and-snow питания</i>					
1.	Sokh – Sarykanda	2480	45.41	2.52	0.92
2.	Zeravshan – Dupuli	10200	156.5	1.58	0.83
3.	Koksu – Kurbankul	174	2.59	1.16	0.84
4.	Oigain – river mouth	1010	28.7	1.03	0.78
5.	Maidantal – river mouth	471	18.6	0.93	0.81
6.	Pskem – Mullala	2540	77.4	0.78	0.81
Mean value					0.83
<i>Rivers with snow-and-glacial alimentation type</i>					
7.	Aksuv – Khisorak	755	11.8	0.64	0.77
8.	Zaaminsu-Duoba	546	1.909	0.53	0.71
9.	Chatkal-Khudaidotsai	6580	110.6	0.50	0.75
10.	Chilarma – river mouth	103	3.1	0.45	0.74
11.	Yakkabag – Tatar	504	5.95	0.43	0.72
12.	Uriklisai – Ismani river mouth	149	0.704	0.42	0.68
13.	Chimgansai – Chimgan canal	23.3	0.3	0.39	0.67
14.	Nauvalisai – Sidjak	99.4	3.83	0.38	0.70
15.	Sherabad – Derbent	949	5	0.34	0.73
16.	Ugam – Khodjikent	869	22.8	0.33	0.76
17.	Akbulak – river mouth	886	19.4	0.32	0.74
18.	Kyzylcha – Iertash river mouth	51.6	1.05	0.31	0.70
19.	Jinnidarja – Dzhauz	152	1.49	0.31	0.66
20.	Yangikurgansai – Yangikurgan canal	33.7	0.67	0.3	0.60
21.	Tankhazdarja – Kattagan	435	3.98	0.29	0.69
Mean value					0.71
<i>Rivers with snow alimentation type</i>					
22.	Uradarja – Bazartepa	1250	4.26	0.25	0.66
23.	Gavasai – Gava	657	6.049	0.25	0.69
24.	Karadarja – river mouth	2340	24.84	0.24	0.69
25.	Sangardak – Kingguzar	901	15.8	0.23	0.76
26.	Shaugaz – Karatash	65.8	0.469	0.22	0.64
27.	Amankutan – Amankutan	57.8	0.969	0.21	0.64
28.	Sanzar – Kirk	570	1.982	0.21	0.69

1	2	3	4	5	6
29.	Chadaksai – Zhulaisai	350	3.75	0.19	0.66
Mean value					0.68
<i>Rivers with snow-and-rain alimentation type</i>					
30.	Abzhasai – Abzhas	70.5	0.6	0.17	0.68
31.	Nishbash – Nishbash	141	2.76	0.16	0.68
32.	Akhangaran – Iertash river mouth	1110	19.9	0.15	0.70
33.	Kashkadarje – Varganza	511	5.24	0.15	0.69
34.	Dukantsai – Dukant	201	4.89	0.14	0.65
35.	Karabau – Samarchuk	166	3.19	0.13	0.71
36.	Khalkadjar – Bazarjoy	577	6.4	0.11	0.72
37.	Biglyar – Biglyar	180	0.609	0.10	0.56
38.	Kichik Uradarja – Gumbulok	1570	1.43	0.09	0.55
39.	Akdarja – Agalyk	70.9	1.04	0.07	0.63
Mean value					0.66

On the base of calculated values their mean values were estimated according to the river alimentation type. For the rivers of I type, i.e., for the rivers with the glacial-and-snow alimentation type $K_0 = 0.83$, II – for the rivers with snow-and-glacial alimentation type $K_0 = 0.73$, III – for the rivers with the snow alimentation type $K_0 = 0.68$ and for IV type – i.e., for the rivers with snow-and-rain alimentation type $K_0 = 0.66$.

The analysis of the obtained results has shown that the different values of the low-water factors (K_0) on the studied rivers depend on the sources of their alimentation. Taking this regularity into account, we have studied the relationship between the low-water factor K_0 and Schults' factor (δ), which determines the type of the river alimentation source (fig. 1).

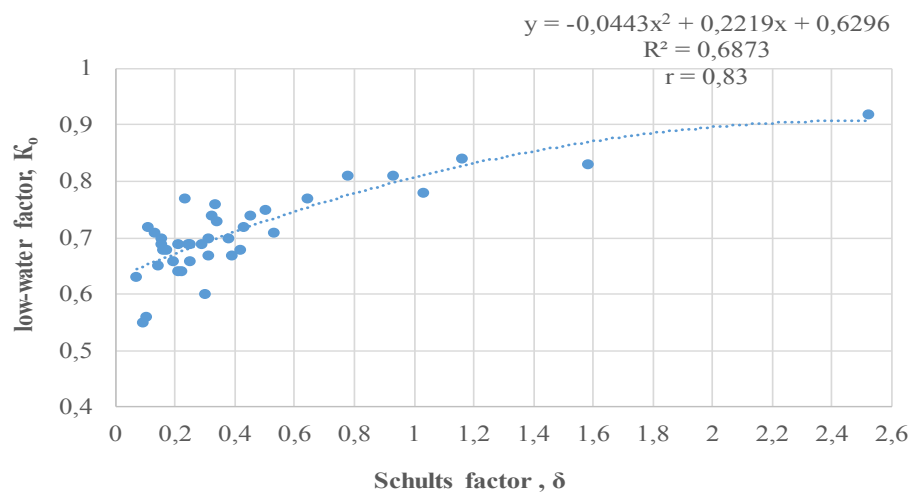

Figure 1. Graph of correlation between low-water factor (K_0) and Schults' factor (δ)

As it is seen from the graph, the correlation between the low-water factor (K_0) and Schults factor (δ) is characterized with curvilinear relation which is described with the following equation:

$$K_0 = -0.0443 \cdot \delta^2 + 0.2219 \cdot \delta + 0.6296 \quad (3)$$

Pairing correlation factor determining closeness of relationship and accuracy of the regression equation (3) is 0.83 ± 0.034 .

From this it follows that the flow of rivers with the glacial-and-snow alimentation type is regulated (normalized) in the long-term period with the melting water of glaciers and perennial snow, and in the result of this the deepening of the low-water situation in the low-water water are not observed.

Summarizing all mentioned above, the low-water norm ($Q_o^l, m^3/c$) for the river flow can be calculated with the following formula:

$$Q_o^l = K_o \cdot Q_i, \quad (4)$$

where: K_o – low-water factor; its value is estimated in accordance with the type of the river alimentation; Q_i – mean yearly discharge value, m^3/s . It is necessary to note that the low-water norm can be estimated not only for one year, but also for the whole long-term period.

Conclusions. On the base of results of studies, the following conclusions and proposals have been made:

1. The ratios between the mean yearly discharge values for the low-water years (Q_{me}^l) and the flow norm (Q_o) are estimated for the whole long-term period calculated.

2. For the first time on the base of the mean values of calculated ratios the notion of “low-water factor” (K_o) was introduced, and its mean values were estimated for each alimentation type according to V.L. Schults classification.

3. Statistical assessment of closeness of relationship between low-water factor (K_o) and Schults’s factor was carried out. It is recommended to use the regression equation derived with sufficient degree of relationship closeness in hydrological calculations for the planning of different water economy activities. For example, with the use of Schults’s factor the low-water factor can be estimated for the unstudied rivers;

4. Design formula was proposed for estimation of the low-water norm ($Q_o^l, m^3/s$) with the use of the low-water factor;

5. For the rivers with the glacial-snow alimentation type the values of low-water factor K_o vary within 0.78–0.92; for the rivers with snow-glacial alimentation type the low-water factor value varies within 0.60–0.77; for the rivers with snow and snow-rain alimentation type it varies within 0.64–0.76 and 0.52–0.72, respectively;

6. The proposed design formula ($Q_o^l = K_o \cdot Q_i$) makes it possible to estimate the low-water norm for individual year or in average for the long-term period. The practical value of this norm is manifested in the following:

- it is used for the assessment of the water safety observations on rivers in the low-water years;
- it is used in the low-water years for the most rational use of the water resources of water storages in the mountain river beds;
- it is used for definition of the limiting values of the water intake to irrigation canals;
- with the use of the calculated low-water norm and cyclicity of the river flow variations the planning of agricultural crops seeding on irrigated areas is feasible;

7. If to take into consideration that the results of conducted studies are characteristic for all mountain rivers on the territory of Central Asia, then the values of the design formulas proposed above become more ponderous.

References:

1. Agaltseva N.A., Pak A.V., Novikova V.A. Hydrological drought in Uzbekistan, cause analysis and possibilities of forecasting // Proceedings of the Scientific Research Hydrometeorological Institute, – 2010. – Tashkent: – Vol. 12(257). – P. 55–63.
2. Kovalev Yu. S., Mavlonov A. A. On the low-water problem in Syrdarja and Amudarja river basins // Proceedings of Republican Scientific–and–Practical Conference. – Tashkent: GIDROINGEO, – 2008. – P. 15–20.
3. Turgunov D. M. On hydrological indices and terms applied in the studies of the low-water years carried out on the rivers // Proceedings of the Geographic Society of Uzbekistan. – Vol. 46. – Tashkent. – 2015. – P. 169–173.
4. Turgunov D. M., Rakhmonov K. R. Assessment of the low-water years on the mountain rivers of Uzbekistan regarding the climate change // Regional problems of the water use in the changing climate conditions. International Scientific–and–Practical Conference. – Ufa, 11–12 November, – 2014. – P. 72–76.
5. Khikmatov F. Kh., Turgunov D. M. Low-water years recorded on mountain rivers, their norm and the issues of the accounting for the low-water periods deepening // Trans. of the National University of the Republic of Uzbekistan. – Vol. 46. – Tashkent. – 2017. – No. 3/1. – P. 330–335.
6. Khikmatov F. Kh., Haydarov S. A., Yarashev K. S., Shirinboyev D. N., Ziyayev R. R., Erlapasov N. B., Ganiyev Sh. R. Hydrometeorological conditions and water resources of the Zeravshan River basin. – Tashkent: Science and Technology, – 2016. – 276 p.
7. Chebotarev A. I. General Hydrology. – L.: Gidrometeoizdat, – 1975. – 544 p.

8. Schults V.L. Rivers of Central Asia.– L.: Gidrometeoizdat,– 1965.– 691 p.
9. Scheglova O. P. Alimentation of rivers of Central Asia.– Tashkent: Published by Samarkand State University,– 1960.– 243p.

*Sharipov Shavkat Mukhamadjanovich,
candidate, of geographic sciences
Geology and geography department of the National
University of Uzbekistan Tashkent, Uzbekistan
E-mail: shavkat.sharipov.1977@mail.ru*

THE EXTENT OF DESTRUCTION OF LANDSCAPES IN THE TASHKENT REGION

Abstract: The article points to those parts of landscape of the Tashkent region that have become unfit for use in the economy – destroyed lands and their extension **as a result of** natural and anthropogenic factors.

Keywords: landscape, damaged lands, natural factors, anthropogenic factors and the damaged degree.

Introduction. The origin of damaged lands, restoration, reclamation of landscapes, issues of environmental improvement, mining, agriculture, construction are studied in landscape science as well. The study of “damaged lands” in analyses aimed at the efficient use of landscapes and the improvement of geo-ecological conditions is of great importance. The purpose of this paper is to study the size of areas of the landscapes occupied by the damaged lands, i.e., the examination of the extent of destruction of landscapes.

Basic part. The concepts of “Damaged lands”, “Destruction of landscapes” are based on opinions on the destruction of landscapes to be used in the husbandry of lands under the influence of the human activity. For the first time in science, the concept of “Damaged lands” was applied by the British scientist V. Beaver in 1945. Thereafter this concept was improved by V. S. Eskin [4], K. Wallwork [3], P.I Tomakov [2], Kh. Vakhobov [1], and others.

In these definitions specified in the literature for the concept of disturbed lands, the attention is devoted solely to the human activities (mainly industrial one), while such natural processes as landslide, erosion, subsidence, mudflows, salinization, flooding, swamping and other processes are not taken into account. We are of the opinion that in determining this concept, the following three circumstances must be taken into account:

First, the concept of **damaged land** is associated solely with the human being, its economic activities, and in no way with nature. Hence, the destruction of lands to be used in the husbandry, not only under the

influence of industry or other economic activities, but also subsequently natural processes – is a truth that does not require proofs. For instance, deterioration of quality, the coming into unusable or inadequate state of agricultural lands might be occurred as a result of the irrigation erosion or salinization, the landslide or the formation of a ravine in the summer pastures at the slopes of mountains.

Second, it is necessary to pay attention to the expression **the loss of economic value; unfit for use**. As discussed above, the lands to be used in agriculture may lose their economic value, and become unfit for use not only under the influence of human activity, but also as a result of natural processes. It should be noted that the concept of lands became unusable is used solely in relation to economic activities of the human being. Actually, even on these unsuitable lands there is flora and fauna being a component of nature, among which there is a continuous exchange of substances and energy, while the geographical systems continue to perform their special function. Thus, unsuitable lands do not exist for nature.

Third, the territories, facilities being the source of the adverse environmental impact may arise not only under the influence of industrial or other economic activities, but also as a result of natural processes. For example, exposing of layer of rocks with strong radioactive exposure as a result of a landslide or the formation of ravines, or the spreading of salts over the surroundings located in the bottom of a dry lake under the influence of wind, the flooding of floodplains and the formation of marshy areas during high-water periods and etc.

On the basis of the foregoing, the following definition will be proper for the concept of damaged lands:

Damaged lands – areas with an unfavorable view that have lost their economic importance and become unusable or inadequate for use after human activities and natural processes, as well as being the source of adverse environmental impact due to changes in soil and vegetable cover and stream conditions, the creation of anthropogenic relief. They are sources of contamination of the soil, the water, the air, and complicate the living and functional environment of people.

According to the damaged degree under the influence of natural and anthropogenic factors, the terrains of the Tashkent region are divided as follows and the map has been made according to the present data (Fig. 2):

- 1) 0–1.0% – undamaged;
- 2) 1.1–5.0% – slightly damaged;
- 3) 5.1–10.0% – moderately damaged;

4) 10.1–20.0% – highly damaged;

5) 20.1–30.0% – extremely damaged.

Terrains considered as **undamaged** are mainly 18th, 19th, 20th, 21st, 22nd, 23rd, 24th, 25th, 26th, 27th and 28th terrain types (classification and names of landscapes given on 1-table) on the II, III, IV terraces above the flood plains, relating to the desert-steppe type of the terrain on the piedmont plains (Figure 1), fully developed to be used in irrigated farming.

The sustained reclamation activities are carried out in order to harvest a high yield from crops. Most of the regional settlements are located on these terrains. Therefore, the damaged parts of such terrains are spread out in very small areas, where mainly the processes of ravine, subsoil erosion formations and sometimes landslides are found. Among the anthropogenic factors, there are mainly places of industrial, construction, and household waste accumulations.

Table 1. – Terrain classification of the Tashkent region (according to the classification of V. A. Nikolayev, 1999)

Classification unit	Characteristics of the classification	Landscapes	
1	2	3	
Chapter	Interconnection of geospheres within the boundaries of the geographic crust and the type of their impact	Land – 1–31	
Section	The energy base of the landscapes – regional-zonal differences of the humid-heat balance (at the level of climatic regions)	Subtropics – 1–31	
Subsection	Sector characteristics of the climate, continentality	Subtropics extra arid (steppe) continental	
Family	Regional characteristics at the level of natural and geographical region	Subtropics the Central Asian extreme continental – 1–31	
Class	High-category geomorphological structures (at a mega-form level of the relief), a kind of natural zoning (horizontal or elevated)	Highland – 1–17	Plain – 18–31
Subclass	Layers of the relief height (at a macro-form level of the relief)	High – 1–4, medium-high – 5–12 and low – 13–17 hills	Piedmont lowland – 18–31
Group	Water and geochemical order, moisture ratio	Automorphic – 3–17 Semi-hydromorphic – 1–2	Automorphic – 18–25 Semi-hydromorphic – 26–28 Hydromorphic – 29–31

1	2	3	
Type	Zonal characteristics of the landscapes (soil and geo-climatic features at the level of soil types and classes of plant formations)	Grassy steppe (pasture) – 1–4 Forest-flood plain-steppe (mountain land) – 5–9 Dry steppe (hilly land) – 10–17	Desert-steppe (hilly) – 18–31
Subtype	Soil and bioclimatic characteristics (at the level of the soil subtypes and the plant formation subclasses)	Short-grass glacial and nival deserts – 1 High-grass plains – 2–4 High plain-vegetable-low bush-spruce forests – 5–9 Ephemeral steppes – 10–12 The Turan forb steppes – 13–17	Ephemerical-ephemeral desert steppes – 18–28 Thicket – 29–31
Category	Genesis and morphology of the relief (genetic types of the relief)	The tectonic denudation and the exaration bridge distributors and slopes – 1 The tectonic erosion-denudation slopes, pediments, – 2–3, 5–9, 13–15, 17 The tectonic denudation plateaus – 4 The tectonic denudation peneplains – 16 Erosion-accumulative terraces – 10–12	Erosion-accumulative terraces – 18–29 (I-29; II-27,28; III-26, 25, 24, 23, 22; IV-21, 20, 19, 18) Erosion-accumulative floodplains – 30 Erosion beds and islands – 31
Subcategory	Genesis and lithology of deposits on the ground surface	Magmatic, metamorphic deposits; eluvial – 1, 4,16, dealluvial – 2, 5–8,12–15,17 colluvial – 3,9, proluvial and alluvial rocks – 10–11; Abyssal rock, faceted cobblestone, small-stone, skeletal-loamy, skeleton-crushed-sandy, loess-like and loess deposits.	Deposits; proluvial and alluvial rocks – 18–31; Loess, loess-like sand-loam crushed-stone deposits.
Variety	Similarity of the dominant natural boundaries (similarity of soils, plants, terrains and deposits)	<i>For example:</i> 22. Loess-like deposited plains having the even surface with crops on typical irrigated fallow lands	

Not highly disturbed terrains are 29th terrain type on I terraces above the floodplain, 30th and 31st terrain types located on floodplains and riverbeds, and are used as pastures. There is a partly irrigated arable farming, i.e., rice is grown. The disturbed lands mainly consist of marshy areas and quarries, where sand and crushed stone are quarried for construction. The disturbance degree of the 4th terrain type on high-altitude tectonic peneplains, 5th, 6th, 7th and 8th terrain types in the mountains of medium height, 10th, 11th, 12th, 13th, 14th and 15th

terrain types related to the mountain and valley and low-mountain piedmont flat terrain type is also considered as not highly disturbed. The disturbed parts of these terrains are mainly related to natural phenomena, and consist of landslides and ravines, rocks and soot in some places within small areas. In addition to the abovementioned natural processes in the terrains of the Chatkal and the Kurama ranges, there are also anthropogenic factors, i.e., the mining industry. Quarries, dumps and waste banks in such terrains occupy considerably larger

area, and become the causes of moderate to severe degrees of disturbance of terrains. The 5th terrain type on the northwestern slopes of the Pskem Range (the Machitosgonsay, the Ispaiysay, and the Kaptarkumush valleys) is highly disturbed by landslides and soot, the 5th terrain type on the northwestern slope of the Maydantal range (Tekeshsay Valley) and on the northwestern slope of the Pskem range (Koksu valley) is highly disturbed by soot. The remaining of the 5th terrain types are considered as slightly disturbed.

On the 6th terrain type located on the north-western slope of the Ugam range (Novalisay, Teparasay, Akhalasay valleys) and on the northwestern slope of the Pskem Range (Koksu Valley), the soot is widespread being the cause of the average disturbance degree of terrains. On the 6th terrain type located on the northwestern slope of the Pskem Range (Mulala, Aksarsay valleys), soot and landslides are widespread that occupy 14–15% of terrains and considered as highly changed. The remaining 6th terrain types are considered as slightly disturbed.

Landslides and precipices are relatively widespread on the 7th terrain type of the northern slope of the Kyzylnur mountain (Boshkyzylsay valley), occupy 10.8% of its area and considered as moderately disturbed. The rest of this terrain type is considered as slightly disturbed.

10th, 11th, 12th terrain types on terraces with widespread erosion-accumulative relief forms of medium-altitude mountains are also included into a slightly disturbed group. These terrains are developed where villages, gardens and vineyards are sprung up. The sustained reclamation activities against various natural processes are carried out in areas under crop and villages. Therefore, the disturbed parts of these terrains are distributed in very small areas, and mainly ravines, landslides, and sometimes landslides are found. Among the anthropogenic factors, there are mainly places with accumulated construction and household waste.

Moderate and severe disturbances had been occurred in some 10th terrain types. Multiple soot on the Urungachsay terrain and widely spread landslides on the terrains where the Chimgan and Khumsan villages are located have led to the fact that the disturbed lands in these terrains occupy a larger area and the disturbance degree of the terrains is considered as severe. The disturbance degree of the remaining part of this terrain type is defined as not strong.

The moderately disturbed terrains occur mainly in certain parts of 2nd, 5th, 6th, 7th and 9th terrain types on medium and high altitude mountains. Causes of their moderate and severe disturbances were mainly soot and landslides, and on the 7th terrain type were ravines and landslides.

Highly disturbed terrains occur mainly in the 1st and 3rd terrain types and in the certain 2nd, 9th and 17th terrain types.

1st terrain type is located in the glacial-nival zone, high watershed parts over 3400–3600 m of the Ugom, the Pskem, the Chatkal and the Kurama mountains, therefore their formation and development are under strong influence of perpetual snows and glaciers, as well as from waters, temperature fluctuations generated by them. Therefore, a significant part of these terrains are not suitable or suitable to a very little degree for economic use due to large areas covered with soot, hard rocks. In view of this, these terrains are highly disturbed.

Even the 3rd terrain type does not occupy large areas it covers the places adjacent to the watershed of the valleys with small rivers, originating from the high-altitude mountains. Their significant part (from 12.8% to 59.9%) consists of soot matters, hard rocks, that are unusable for economic use, and are considered as highly disturbed.

The 2nd terrain type on the southwestern slopes of the Ugam range, on the southwestern slopes of Maydantal mountain, on the northwestern slopes of the Pskem range, on the north-western slopes of the Koksu range, and on the terrains adjacent to the watershed of the Babaytag and Babaiyob mountains are highly disturbed by soot and landslides due to a relatively large slope of the relief.

Landscapes of the 9th terrain type on the north-western slopes of the Pskem range are highly disturbed by soot.

17th (17–7) terrain type located near the Pskent town is highly disturbed mainly due to precipices or more specifically due to irrigation erosion. The Urtaaryk having the length from the Akhangaran river to the Pskent town and the circular fields and its streams, transformed 14.8% of the area of this terrain into the precipices.

Extremely disturbed terrains occur in the certain 1st, 2nd, 3rd, 9th, 16th and 17th terrain types.

Landscapes of the 1st terrain type, occupying the watershed areas of the Pskem range, the watershed places of the Chatkal range are considered as extremely disturbed.

31.7%, 21.3% and 20.9% of these terrains cover soot, hard rocks, perpetual snows and glaciers, respectively.

Most of the landscapes of the 2nd terrain type on the southwestern slopes of the Ugam range, on the northwestern slopes of the Pskem range (21.9%, 30.4%, 31.5%, 21.8%, and 23.1%, respectively) are covered with soot, landslides. Therefore, it is considered as an extremely disturbed terrain.

The huge part of the landscapes of the 3rd terrain type on the southwestern slopes of the Maydantal range, on the northwestern slopes of the Pskem range (59.9% and 34.4% respectively) is covered with soot, hard rocks, landslides, and is considered as a highly disturbed terrain.

The landscape of the 9th terrain type on the northwestern slopes of the Pskem range is considered as highly disturbed as a result of formation of the canyon due to the strong erosion of the Machitogansay valley, that is, 28.5% of the territory is covered with soot and hard rocks.

16th and 17th terrain types are mainly distributed in the Akhangaran valley and related to moderately, highly and extremely disturbed terrains. The 16th terrain type

in the Almalyksay basin is considered as extremely disturbed due to the fact that 89.5% of the area is occupied by the Kalmokkyr quarry. 26.6% of the area of the 17th terrain type is occupied by the Kalmokkyr and the Dalneye quarries and their dumps.

The 30th terrain type in the Akhangaran valley is considered as highly disturbed due to the fact that 37.3% of the area is occupied by the waste banks from the Almalyk Mining and Metallurgical Complex and the settling basin for wastewater of this complex.

Conclusion. Both natural and anthropogenic factors being the reasons for the transformation of the terrains of the Tashkent region into unfit condition for economic use, are changed as they approach the mountain watersheds from the piedmont plains, obeying the regularity of altitudinal zoning. If the anthropogenic factors play an important role on the terrains of the piedmont flat parts, then in rising up the share of natural factors increases, and the terrains of the mountain watersheds and the adjacent territories are mainly under the influence of the natural factors.

References:

1. Vakhobov Kh. Evaluation and forecast of the formation of mining landscapes and the physical and geographical bases for their reclamation // Doctoral thesis in geology – Tashkent. – 2001. – 48 p.
2. Tomakov P. I., Kovalenko V. S. Rational land use in open mining operations. – Moskow. Nedra. – 1984. – 213 p.
3. Wallwark K. The disturbed lands. – M., “Progress”, – 1979. – 268 p.
4. Eskin B. C. Reclamation of lands disturbed by open development. Publishing house – Moskow. Nedra. – 1975. – 184 p.
5. Sharipov Sh. M., Ospanov T. M. Ecological and economic aspects of reclamation of disturbed lands and creation of cultural landscapes // Modern problems of geography science and education. Materials of the Republican Scientific-Practical Conference. – Tashkent. – 2015.

*Egamberdiev Khamrakul Tursunkulovich,
Petrov Yuriy Vasilovich,
Prof. Dr., National University of Uzbekistan
named after Mirzo Ulugbek,
lecturer, of the Faculty of physics,
Tashkent city, Uzbekistan
E-mail: ext1961@mail.ru*

THE TECHNIQUE FOR CALCULATION OF THE NORMALIZED FACTOR OF THE DIRECT SOLAR RADIATION WEAKENING

Abstract: The technique is developed for the calculation of the new parameter: normalized factor of the attenuation of the direct solar radiation, as well as of its components – attenuation in the ideal atmosphere, attenuation with water vapor and atmospheric aerosols.

Keywords: Normalized factor for the solar radiation attenuation, attenuation of solar radiation with water vapor and atmospheric aerosols.

Introduction. Only part of the solar radiation which enters the upper atmosphere border reaches the Earth surface. After penetration through the atmosphere layer it is attenuated substantially due to the following main physical processes: molecular (Riehl) and aerosol (Mi) dissipation, as well as with the water vapor absorption and by the aerosol of the natural and anthropogenic origin. The part of the solar radiation which reaches the underlying surface, presents the direct and solar radiation [2].

The ability of atmosphere to transmit the directed solar radiation is called as the Earth atmosphere transparency. Spectral and integral atmosphere transparencies are distinguished. Spectral transparency is the ability of atmosphere to transfer the directed radiation in the relatively narrow parts of spectrum. Integral transparency – is the ability of atmosphere to transfer the directed radiation in the wide wave range. The transparency of atmosphere is one of indicators of physical processes taking part in the atmosphere. Different characteristics which are used in the studies on the formation and change of weather and climate of our planet are used for the quantitative expression of the atmosphere transparency. They are also used for the solution of tasks of the surface monitoring of atmospheric transparency by the measured values of the direct solar radiation [2].

Objective of the work: to elaborate the method for calculation of the new normalized factor of the solar

radiation attenuation by the atmosphere as the integral transparency index.

This index characterizes the optical characteristics of the air mass located over the observation point, and depends on the moisture content of air and on the concentration of atmosphere aerosol in it, i.e.

$$P_a = P_{u\delta} + P_{as} + P_{aa}, \quad (1)$$

where: $P_{u\delta}$ – the portion of the weakened solar radiation in the ideal atmosphere, P_{as} – attenuation of solar radiation with the water vapor, P_{aa} – attenuation of solar radiation with the atmosphere aerosol.

Discussion of results. Let us consider the sequence of calculation of all summands in the formula (1).

P_a – normalized factor of attenuation of solar radiation with the Earth atmosphere is calculated with the formula:

$$P_a = \frac{J_0 - J_{m=2}}{J_0}, \quad (2)$$

where: J_0 – solar constant which is 1,367 kWt/m², $J_{m=2}$ – direct solar radiation reduced to the optical mass the value of which is two by the method of Sivkov S. I. [4].

Survey of works on the investigation of the solar radiation attenuation in the ideal atmosphere at the Earth surface level is given in [1, 3]. The data of Sivkov S. I. [4] calculation are the most reliable and comprehensive ones. Calculations of the change of the direct solar radiation with height in the ideal atmosphere with the unit optical mass are made by Kastrov V. G. [1]. The vertical

profile of the direct solar radiation in the ideal atmosphere with $m = 1$ is given in (Fig. 1).

The obtained data are reduced to the optical mass value which equals 2 by the technique of Sivkov S. I.

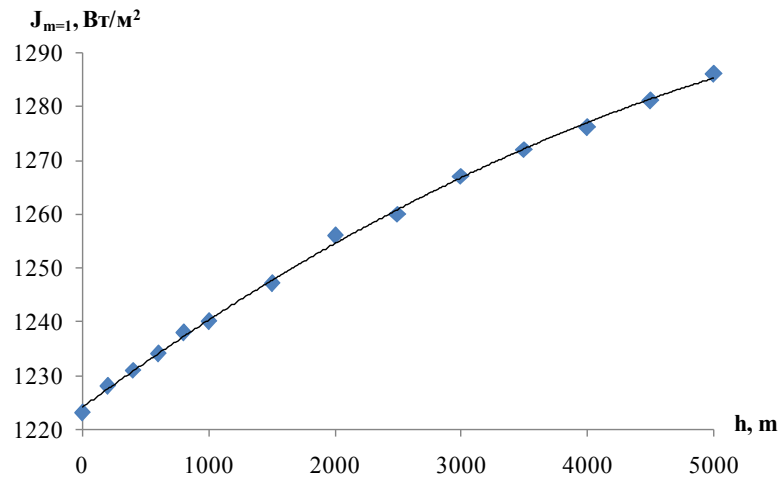

Figure 1. Vertical profile of the direct solar radiation in the ideal atmosphere with $m = 1$

Attenuation of the direct solar radiation in the ideal atmosphere P_{ua} is calculated with the formula:

$$P_{ua} = \frac{J_0 - J'_{m=2}}{J_0}, \quad (3)$$

where: $J'_{m=2}$ – direct solar radiation in the ideal atmosphere reduced to the optical mass value which equals 2.

Figure 2 presents the vertical distribution of the attenuation of the direct solar radiation in the ideal atmosphere up to 5 km elevation from the sea level.

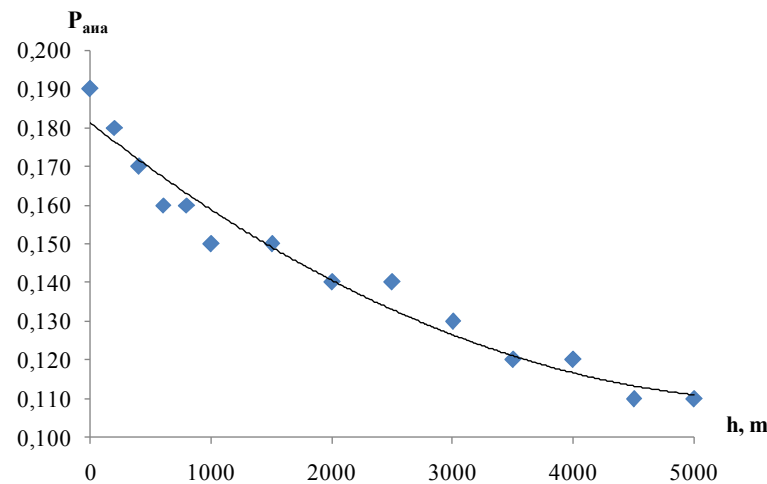

Figure 2. Vertical profile of the normalized factor of the attenuation of the direct solar radiation in the ideal atmosphere

In (Table 1.) P_{ua} values are given for the actinometrical stations of Uzbekistan.

Table 1. – P_{ua} values for the actinometrical stations of Uzbekistan

Station	Elevation, m	P_{ua}
1	2	3
Tashkent	477	0.17
Fergana	578	0.16
Samarkand	726	0.16

1	2	3
Karakalpakiya	124	0.18
Takhiatash	76	0.19
Tamdy	236	0.17
Termez	308	0.17
Kyzylcha	2070	0.14

Attenuation of direct solar radiation by water vapor is calculated with the Meller's formula [2]:

$$\Delta J = 0.172(mW_{\infty})^{0.303}, \quad (4)$$

where: ΔJ – intensity of radiation absorbed with the water vapor in cal/sm² min, $m = 2$ – optical atmosphere mass, W_{∞} – the layer of deposited water in sm.

The layer of deposited water is calculated with empirical formula (5):

$$W_{\infty} = 0.163e + 0.367, \quad (5)$$

where: e – water vapor pressure. This formula was derived by Yu. V. Petrov and Kh. T. Egamberdiev for the conditions of Uzbekistan.

Attenuation of the direct solar radiation with the water vapor is calculated with formula:

$$P_{as} = \frac{\Delta J}{J_0}, \quad (6)$$

where: ΔI – intensity of radiation absorbed with the water vapor in kWt/m²,

J_0 – solar constant which is 1.367 kWt/m².

Attenuation of the direct solar radiation with atmospheric aerosol is calculated as the remainder term in the equation (1).

Table 2. – Attenuation of the direct solar radiation with the water vapor (P_{ab}) and atmospheric aerosol (P_{aa}) on the selected stations of Central Asia

Station	months									
	March		May		July		September		November	
	P_{as}	P_{aa}	P_{as}	P_{aa}	P_{as}	P_{aa}	P_{as}	P_{aa}	P_{as}	P_{aa}
Aral Sea [3]	0.12	0.07	0.13	0.12	0.15	0.13	0.13	0.08	0.11	0.04
Tashkent [3]	0.12	0.09	0.14	0.13	0.14	0.15	0.13	0.15	0.12	0.09
Ashgabad [3]	0.12	0.11	0.14	0.16	0.15	0.20	0.13	0.19	0.12	0.10
Tashkent [a*]	0.12	0.16	0.13	0.20	0.14	0.21	0.13	0.20	0.12	0.16

* the author's data

Table 2 presents the values of attenuation of the direct solar radiation with water vapor and atmospheric aerosol for the actinometrical stations of Central Asia which are characterized with similar physical-and-geographic conditions. The data are taken from the monograph [3], where the data of actinometrical observations for the first half of XXth century are generalized. Separate row presents the author's calculations made by the data of observations for the last decades. Analysis of data presented in the table gives the ground to make the following conclusions. First, there is no difference between the values of attenuation of the direct solar radiation with water vapor, both between the stations and the values measured at the same station (Tashkent) for the different periods of time. In addition, the data of the direct measurements of the water layer deposited in atmosphere which were

obtained in Astronomy Institute of the Academy of Sciences of the Republic of Uzbekistan were used. From these data it follows that this layer in May of 2015 was 14–17 mm which corresponded to the attenuation factor of 0.12–0.13. This result does not differ too much from our calculation data. It proves that we used the formula applied for calculation of attenuation of the direct solar radiation with water vapor correctly. Second, attenuation of the direct solar radiation with aerosol in Tashkent during the last years increased 1.4–1.8 times comparing with the first half of XXth century. Third, the input of atmospheric aerosol to the general attenuation of the direct solar radiation increased during these years.

Conclusions. Thus, the technique for calculation of new index of the atmosphere transparency is proposed: the normalized factor of the solar radiation

attenuation in the Earth atmosphere. The graph for estimation of the attenuation of the direct solar radiation in the ideal atmosphere depending on the height of the point of actinometrical measurements is constructed. The empiric factor in Meller's formula is pro-

posed for attenuation of the direct solar radiation with the account of physical-and-geographic conditions of Uzbekistan. Attenuation of the direct solar radiation with atmosphere aerosol is calculated as the reminder term in equation (1).

References:

1. Kastrov V. G. Selected works on the physics of atmosphere. Gidrometeoizdat. – L.,– 1979.– 328 p.
2. Prokhorov A. (chief editor). Physical encyclopedic dictionary.– Moscow. Pub. “Soviet Encyclopedy”,– 1984.– 945 p.
3. Radiation characteristics of atmosphere and Earth surface. Edited by Kondratjev K. Ya. Gidrometeoizdat. – L.,– 1969.– 564 p.
4. Sivkov S. I. Methods of calculation of the solar radiation characteristics. Gidrometeoizdat, – L.,– 1968.

Section 3. Journalism

*Alimova Gulnoza Bakhshiloevna,
teacher, of the Uzbek State University of World Languages,
Faculty of International Journalism
E-mail: alimova.g@list.ru*

SPECIAL FEATURES OF JOURNALISM IN SOCIAL SITES. PERFORMING LANGUAGE AND STYLE OF TEXT DELIVERY

Abstract: The article is dedicated to the phenomenon of journalism in social networks. The author in his research studies the role of journalism in social networks and citizen journalism in the modern information society, the relationship with traditional journalism. And in the article special importance is attached to the language of journalistic work in so-called network journalism and the style of submitting materials.

Keywords: social networks, civic journalism, convergence, media transformation, media language.

In order to completely investigate questions of journalism in social sites, it is necessary to analyze and understand such concepts as “journalism in social sites”, “civil journalism” and to some others which lay close to them, like “people press”, “national journalism”, “social journalism” and so on. Besides, it is vital to understand which language do the actually “speak”.

“In our ordinary life we use two types of languages – complicated written and simple oral. Internet had created a third type – mixed. It united accuracy of the first type and combined it with brevity of the second one [1]. Moreover, this third type of a language is now enriching its lexicology. Internet slang has already become a dialect. While availability of the new technologies increases influence of the internet to the Russian language more and more.”

It would be correct to clarify the initial position from the very beginning. It concludes in the following. As we suppose, in an absolute literally way there are no such separate, independent concepts as “civil journalism” or “blogging journalism” and it is also wrong to group their styles into special categories. There is an activity, close to journalism, which is performed in the social sites by civilians of different countries, bloggers. Meanwhile, some

parameters of massive social work in social sites are equal to the job of professional journalists, while some are not.

We shall try to find out, what common sides network journalism has with professional journalism and what are differences between them.

It is quite essential for theoreticians and practitioners to approve their positions on question, is journalism in social sites actually journalism, and in which degree it can be accepted as journalism in the internet. But it is impossible to ignore point of view of a great amount of people who call themselves as civil journalists and bloggers and also work in the sphere of mass media. In the process of their work network journalists can be inaccurate, optional in different qualities of them, but the fact that they are successfully working in the global net, and deliver demanded information to the public cannot be doubted.

Generally, auditory never question does network journalism`s works require to demands of classic or qualified journalism. Auditory is more interested in information itself: message on the events, instant delivery of information, absence of censorship (even editorial), unsmoothed character of the news and et cetera. All these working process forms are done only for the sake of

providing the consumers with original and operative information. In accomplishing this target, representatives of the “civil” or “blogging” journalism are considered as leaders in comparison with professional journalists in the way of delivery of the information. On the other hand, their activity cannot be defined as equal, as both of these types of journalists work in different poles of professional, ethnic and juridical activeness.

What are common and different sides of social networks and social journalism? A. I. Danilenko writes: “Social journalism and social sites have common concept – “social”. Concept “social” is identified with position of different social subjects in society, their lifestyle, activities on keeping or developing their social status, regulating their relationships with other subjects, social institutes, with society in common... In this way, social networking and social journalism – inseparably connected with each other. If first identifies social subject in the society, social journalism affects interests and problems of the subject itself and assists in solving them.” [2] Main idea of social journalism is simple – straight and direct protection of civil society’s interests, which necessity is discussed by a lot of people, while only few truly act in order to accomplish this protection. This position of civil journalists is expressed by their immediate analysis and ability of arising actual problems in public. Plausible, it less affects on accepting important powerful decisions. But it is clear that social journalism represents interests of wider public and secondly, with development of democracy, positions of social journalism will be more and more strengthened.

As main aspect one should consider language and material delivery style in each of discussed above types of modern journalism. After all, because of convergence of the journalism, language of modern mass media has also transformed. Although, not only language has changed, but all newest journalism in common. “Transformation of journalism can be noticed even in design of newspapers and television programs, where designer methods are taken from interactive publications” [1, 3]. “Theoreticians of mass media, understanding character of innovations in world and press, more often change the accent of realizing the role of press as a social institute, which functioning is defined by socio-political situation, researches of mediadiscourse [4, 3, 17]. Nowadays mass media not only became various and different, giving the

auditory the right to choose, but abundance of information and will to be more likely chosen by auditory made language of material delivery much more simple. “The new era brought sharp depletion of the journalistic language, – writes famous Russian television journalist, P. Lobkov – Especially synonymic diversity had been damaged. Language of the mass media now gets closer to the language of officialdom. In this situation hard and detailed work with language – is a battle against tendency of stupefying the nation” [5, 4]. Do we wish it or not, the age of information demands from journalistic material complete matching with expectations of readers auditory. And mainly the bet are made for efficiency, actuality and topicality of the material. Good quality of a text, is naturally welcomed, but anyway it has to be with characteristics listed above, but not instead of them. And journalism in social sites cannot be an exception for this rule.

Social sites perform different functions. A. A. Morozova writes about it: “Social media today represent not only instrument of massive communication, but also serve to users in order to complete various tasks. One of the types of social media are social sites. They are such a place, where one can completely fulfill all his necessities, including necessity in getting new information [5, 6]. At the same time, there is no doubt that informational function stays the major one in social media. And this takes us to different consequences, like majority of simple civilians in social sites in comparison with professional journalists.

One of forms of behavior in social sites for people is civil journalism. Is there actually such concept as “civil journalism” or not – is discussed a lot. Some specialists state, that it can’t be separated civil journalism, because all journalism is actually civil, and calling journalism as civil means nonsense (B. Nazarov). The others suppose, that all journalism in social sites, besides e-versions of official and commercial editions, is social. There are authors who say that “civil journalism works on the basis of a principle “human to human – media” [6, 7].

In our definitions, we shall follow wide-spread opinion on civil journalism: “Civil journalism (it also can be called social, united or democratic) – is a type of journalism which got global development with the evolving of the internet and new digital technologies. Usually civil journalists cover events which left unseen for traditional mass media sources. Often, reports of civil journalists

attract same amount of auditory as usually attend to traditional huge mass media sources [7, 8]. We should also add, that the structure of civil journalism consists from different forums, chats and other possible platforms for mutual civil informational exchange work.

Surely, civil journalism and journalism in social sites have their own disadvantages, which can't be unnoticed. Firstly, the level of literary language usage is not high enough, punctuation and stylistic rules are not properly followed. Y.M. Lotman once said: "Transforming an event into text means retelling it in a system of a language which means, making it to obey certain structure organization [9, 8, 99]. How resonance should be, from retelling in such delivery?

Secondly, and it is one of the main disadvantages, there are a lot of obscene language, impolite treatment, tactless deterrence of opponents, unfounded accusations, rude language and so on.

But this definition is more related to civil journalists, although in social sites sphere of Uzbekistan not infrequently one can meet professionals. For instance such famous uzbek bloggers as Nargiz Kasimova (nargis.uz), Muslim Mirzajonov (mnm.uz), Sanjar Said (sanjarsaid.uz) are qualified specialists in the sphere of journalism. Some of them even have PhDs.

What kind of relations between civil and professional journalism in the social sites exist these days? We suppose, that they can easily coexist together next to each other. Such rivalry will be useful as for the first ones, as for the seconds by making them to develop their work quality, in order to attract as more auditory as possible.

We do not share the point of view, which states that professional journalism in web is primary, while civil is

secondary. Advantages listed above and others also display, that workplace in the net and number of auditory is enough for both of types of journalism. Civil journalism cannot completely substitute professional journalism, although there are lot of such talks. Similarly there is no reason in refusing to acknowledge civil journalism just because of often mistakes made by its representatives, because of unpreparedness to "talk correctly". The fact that civil journalists supply auditory with photos and amateur footages of rare events, which are documentary enough materials, gives us a right to say that they are necessary for the society.

So, both types of massive informational activeness have its own right of existence. The most interesting fact is that both civil and professional journalists not only never consider each other as rivals, but even cannot dispense without each other, and their work is mutually fulfilled with these types of journalism.

Language of the journalism in the social sites will always differ from the language of professional journalism, as anyway in social sites journalism there are mainly representatives of civil journalistic world. Fortunately at least "oblonsky" ("write as you hear" language based on wrong orthography) [9, 10] language while delivering journalistic material not so widely used as in simple network communication. It would really negatively affect on quality of the text. Questions of delivery and style is better to be left for authors themselves. Individuality and original delivery is also welcomed, but major thing is that, we should understand, that suppression of "informational hunger" should be done with low quality "products". Because journalism, despite all its metamorphoses, still has to be socially useful.

References:

1. Zubkov I. G. Genre, language and style of web publications. Analysis of the content component of Internet texts / IGZubkov // Modern research of social problems (electronic scientific journal) – 2013. – No. 10 (30) [Electronic resource] URL: <https://cyberleninka.ru/article/n/zhanr-yazyk-i-stil-veb-publikatsiy-analiz-kontentnoy-sostavlyayuschey-internet-tekstov> (reference date: 10.02.18)
2. Danilenko A. I. Social journalism and social networks: interrelation and interaction / A. I. Danilenko // Blog of Rusfet Kadyrov – 2012.05 [Electronic resource] – URL: <http://www.rusfet.com/2012/05/-po-smm.html> (reference date: 8.02.18)
3. Smetanina S. I. Mediatext in the system of culture. – St.- Petersburg, – 2005. – 17 p.
4. Komsomolskaya Pravda, – No. 57. – 2010.
5. Melnichuk I. V. Specificity of the content of news urban public in the social network (on the example of "VKontakte") / IV Melnichuk – 2017. Mass communication. Journalism. Mass media (media) [Electronic resource]

- resource] – URL: <https://cyberleninka.ru/article/n/spetsifika-kontenta-novostnyh-gorodskih-publikov-v-sotsialnoy-seti-na-primere-vkontakte> (reference date: 10.02.18)
6. Melnichuk I. V. Specificity of the content of news urban public in the social network (on the example of “VKontakte”) / IV Melnichuk – 2017. Mass communication. Journalism. Mass media (media) [Electronic resource] – URL: <https://cyberleninka.ru/article/n/spetsifika-kontenta-novostnyh-gorodskih-publikov-v-sotsialnoy-seti-na-primere-vkontakte> (reference date: 10.03.18)
 7. Wikipedia – a consolidated encyclopedia [Electronic resource] // URL: <http://en.wikipedia.org>. (date of circulation: 19.04.18)
 8. Lotman Yu. M. Text and function / I. M. Lotman / Izbr.staty in 3 vols.– T. 1.– Tallinn,– 1992.– 99 p.
 9. Surviki – network educational and methodical encyclopedia [Electronic resource] URL: <http://surwiki.admsurgut.ru/wiki/index.php> (reference date: 8.04.18)

Section 4. Computer science

*Khujaev Otabek Kadambayevich,
Urgench branch of Tashkent University
of Information Technologies Researcher,
Computer engineering department
E-mail: otabek.hujaev@gmail.com*

SELECTION OF ARCHITECTURE AND TRAINING ALGORITHMS OF NEURAL NETWORKS FOR CLASSIFICATION TASK SOLUTIONS

Abstract: The architecture of neural network for classification task solutions and selection of training algorithm are described in the article. The task has been solved with multilayer neural network by the method of back-propagation.

Keywords: multi layer feedforward network, backpropagation, hidden layer, classification.

1. Introduction

Construction of multi-layer neural networks and their implementation in actual (universal) task solutions is considered to be the urgent and complex tasks in branch problem solving. For example, exchange forecast, optical and acoustic signals recognition, automation of medical diagnosis based on medical data and other public sectors can be referred to such tasks.

The theory of neural networks is one of the universal instruments and it is developed with regard to the definite task of a branch. The definition of neural network architecture, as well as the choice of learning algorithm of neural network or the creation of such algorithms can be considered actual, especially, in the solution of the assigned task.

2. Statement of the problem

The training samples are given as following:

$$X_1 = \begin{pmatrix} x_{11}^1 & x_{11}^2 & \dots & x_{11}^N \\ x_{12}^1 & x_{12}^2 & \dots & x_{12}^N \\ \dots & \dots & \dots & \dots \\ x_{1n_1}^1 & x_{1n_1}^2 & \dots & x_{1n_1}^N \end{pmatrix},$$

$$X_m = \begin{pmatrix} x_{m1}^1 & x_{m1}^2 & \dots & x_{m1}^N \\ x_{m2}^1 & x_{m2}^2 & \dots & x_{m2}^N \\ \dots & \dots & \dots & \dots \\ x_{mn_{mk}}^1 & x_{mn_{mk}}^2 & \dots & x_{mn_{mk}}^N \end{pmatrix}.$$

Here the set is defined as $X = \bigcup_{r=1}^m X_r$, $X_i \cap X_j = \emptyset$, ($i \neq j$, $i, j = 1, m$), where x_{pi}^j - is j feature of i object of the class p ; m - the given number of classes; mp - the number of objects of p class.

Imagine we have objects $x = (x^1, x^2, \dots, x^N)$ and $w = (w^1, w^2, \dots, w^N)$ of R^N Euclidean space given as N - dimensional vectors. Then the scalar product of vectors is calculated $(x, w) = \sum_{j=1}^N x^j w^j$.

Let there is given the set of objects $x_i = (x_i^1, x_i^2, \dots, x_i^N)$, $i = \overline{1, n}$; $n = m_1 + \dots + m_m$. The $M \times N$ matrix is given with values that are equal to 1 or -1 which show the membership to the class of respective objects. Matrix element of row and column intersection (i, j) equal to 1 means the membership of i - object to j - class, or if the value is -1, it should be understood that the i - object does not belong to the j class. The elements of the matrix y_{ij} , $i = \overline{1, n}$; $j = \overline{1, m}$; take the values 1 and -1, where n is the number of objects and m is the number of classes.

Introduce the following symbols:

- 1) N - number of features of a given object;
- 2) n - number of objects of learning sample;
- 3) k - number of neurons in hidden layers;
- 4) m - number of classes;
- 5) j - index of j -feature.

- 6) i – index of j - object, for example, x_i^j implies feature- j of object- i
- 7) r – r - neuron of hidden layer
- 8) a_i^r – impact value of r - neuron on i -object. Usually it is defined by formula $a_i^r = (x_i, w_{ir})$
- 9) Threshold function, or logical-sigma function $g(a_i^r) = \frac{1}{1 + e^{-a_i^r}}$, here the effect function of r – neuron on i – object is shown. It can be concluded that the value

of function shows the object’s membership to a particular class.

10) The matrix of expectations

$Y = \{y_i^r : y_{ij} = \{1, -1\}, i = \overline{1, n}; j = \overline{1, m}\}$; which elements can be 1 or -1.

Assume we are given initial data set for classification task from the website <http://archive.ics.uci.edu/ml/datasets.html> shown in the table:

Table 1.

Name of data set	Number of attributes	Number of samples	Type of sample	Number of classes
Iris	4	150	real numbers	3
Blood Transfusion Service Center	5	748	real numbers	2
Spambase	57	4601	real and whole numbers	2
SPECTF Heart	44	267	Whole numbers	2
Wine	13	178	real and whole numbers	3

The elements of column 1 indicate the names of defined popular tasks, the second column shows the number of parameters of investigated objects, the third column gives total number of objects of learning samples, the fourth column gives the types designation of object parameters, the fifth column – is the number of class selection.

Considered tasks are classic examples of experiments in researches. Generally, developed methods and researcher’s algorithms are tested on the above – mentioned tasks.

Task: Selection of efficient algorithms of neural networks training and neural network architecture at classification task solutions based on the above classical experimental data of the table.

Classification task solution made with neural networks application is associated with implementation of two above-mentioned important tasks. Task 1 – selection of neural network architecture. Task 2 – algorithm selection of neural network training.

3. Neural networks architecture and algorithms of neurons learning

Two tasks are continuously interconnected, i.e. selection of neural network architecture and selection of training algorithm of neural network are considered to be a correlated process. Depending on a particular selection of one of the tasks, different results can be derived at classification problem. When selecting the architecture it

is necessary to select an appropriate learning algorithm. Taking into consideration this matching, one can see marked reduction of errors in classification task solutions. The selection of ways of the given tasks is shown below.

3.1. Construction of neural network and its architecture

The construction of a neural network is carried out in two ways: direct and recurrence distribution. When the neural network is created by direct distribution, then the usual neural network consists of input and output layers. The input layer consists of an input vector and a hidden matrix linking with a hidden layer, and the output layer consists of an output vector and output matrix linking with a hidden layer. There is a feedback in recurrently distributed neural networks. It can be described due to the following scheme:

We will use a double-layer direct propagation neural network in construction of a neural network. It is described in the following scheme:

Here $x_i = (x_i^1, x_i^2, \dots, x_i^N) \in X, i = \overline{1, n}$, and $w_{ir} = (w_{ir}^1, w_{ir}^2, \dots, w_{ir}^N) \in W_r^1$ – input vectors, $a = (a_1, a_2, \dots, a_k)$ vector of hidden layer results, $W_{ij}^{(1)}$ – weight matrix of input and hidden layer interaction, $W_{ij}^{(2)}$ – weight matrix of hidden and output layers interaction, $y = (y_1, y_2, \dots, y_m) \dots$ vector of output layer results. n – number of neural network’s input points for the assigned task, it shows the number of data set attributes,

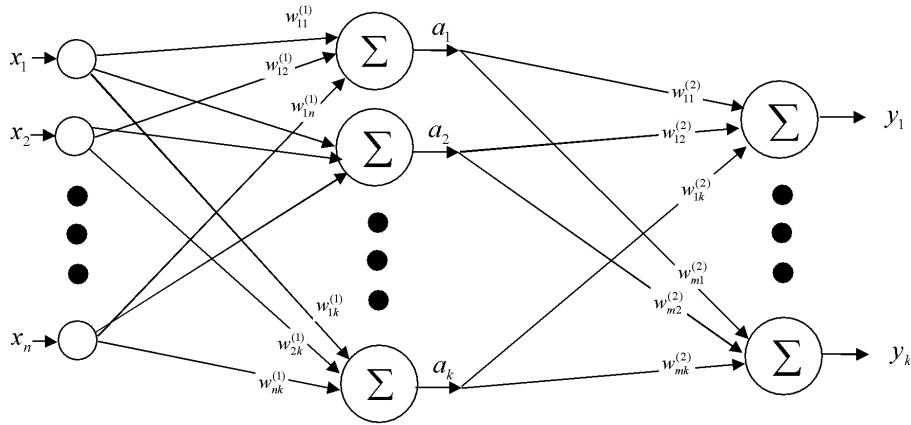

Scheme 1.

m – the number of exit points which equals to the number of allocated classes. Define the number of neurons in the hidden layer with k that in different tasks can be defined in different ways. Usually, for the assigned task multilayer neural network architecture is given as a number triple $(n \times k \times m)$. It is necessary to define the required number of neurons of hidden bonding layer of input and output parameters for the given task solution when selecting the neural network architecture.

3.2. Neural network training

Having built the neural network, the neural network training is considered to be the main stage of training at classification task solutions. The method of back-propagation is used for training multilayer neural networks. Due to this method output value of each neuron is transmitted to transfer function and output values of the transfer function will be an input and resultant vectors for the next layer. Transfer function in some sources is used as an activation function or membership function. The requirement to be differentiable is considered to be the main requirement for these functions. The logic – sigma function and hyperbolic tangent are used for hidden layers of neuron as the activation function of back-propagation and linear functions are used in the neuron’s output layers as these functions are easily differentiated.

$$g(a) = \frac{1}{1 + e^{-a}} \tag{1}$$

$$g(a) = \frac{e^a - e^{-a}}{e^a + e^{-a}} \tag{2}$$

Here, a is the deviation parameter of activation sigma function.

Training of multilayer perceptron is based on the minimization of error function, i.e., the vector of results $A \dots$

and learning sample $y_{ij}, i = \overline{1, n}; j = \overline{1, m}$; has correlation with the weight matrix, and it is expressed as following:

$$E(w_{ir}) = \frac{1}{2} \sum_{r=1}^k (y_{ij}^r - g(a_i^r))^2, i = \overline{1, n}; j = \overline{1, m}; r = \overline{1, k};$$

Algorithms based on back- propagation: 1) Levenberg-Marquardt[5]; 2) BFGS Quasi-Newton[5]; 3) Resilient Backpropagation [5]; 4) Scaled Conjugate Gradient[5]; 5) Conjugate Gradient with Powell / Beale Restart [4]; 6) Fletcher-Powell Conjugate Gradient [4]; 7) Polak-Ribiere Conjugate Gradient [4]; 8) One Step Secant [4]; 9) Gradient descent with momentum and adaptive learning [4].

4. Calculation results and conclusion

Minimal errors in classification reflect different training functions and different number of neurons in the hidden layers. The results have been obtained via MATLAB program. For example, for Wine task solution we will make the calculations for different algorithms and different architectures of neural networks.

1) Select 15% of hash from the initial database N , and mark it L

$$L = \left\lceil \frac{N * 15}{100} \right\rceil$$

Usually the given sample is called a sample test. The given set of sample is marked as $v \in V$.

2) The sample test is allocated from the master training sample and a new organic training sample goes through all the processes of neural network training.. The sample test does not participate in a learning process, but its objects are known to be in membership to any particular class.

3) On this stage there will be carried out the operations based on calculated weight matrix.

$$y' = (w, v_p), y' \in Y, v_p \in V, p = \overline{1, l}$$

4) Let the number q is not distributed to the classes properly.

Thus, for all objects $v_p, p = \overline{1, l}$ will be determined in the membership to any particular class.

Table 2. Then, the number of objects in the class $L-q$ distributed correctly.

$$\text{Classification error is equal to } R = \frac{L-q}{L} * 100\%$$

No.	Algorithm name	Description in MATLAB	Minimum error in classification	Minimum number of neurons in hidden layers
1.	Levenberg-Marquardt	Trainlm	4.09	4
2.	BFGS Quasi-Newton	Trainbfg	3.18	32
3.	Resilient Backpropagation	Trainrp	2.27	8
4.	Scaled Conjugate Gradient	Tarinscg	2.27	4
5.	Conjugate Gradient with Powell/Beale Restarts	Traincgb	2.73	32
6.	Fletcher-Powell Conjugate Gradient	traincgf	1.82	8
7.	Polak-Ribiere Conjugate Gradient	traincgp	2.27	2
8.	One Step Secant	trainoss	1.82	16
9.	Gradient descent with momentum and adaptive learning	traingdx	1.82	32

Table 3. Provide the minimum error for the given tasks using different algorithms and comparative analysis

	Wine		Iris		Blood trans-fusion		Heart		Spambase		Arithmetical mean
Levenberg-Marquardt	4.09	5	2.16	1	21.82	4	19.4	4	6.89	1	3
BFGS Quasi-Newton	3.18	4	3.78	3	24.17	8	22.39	8	10.07	7	6
Resilient Backpropagation	2.27	2	4.86	5	21.82	4	16.12	1	14.1	8	4
Scaled Conjugate Gradient	2.27	2	4.32	4	20.53	3	20.3	5	9.44	5	3.8
Conjugate Gradient with Powell/Beale Restarts	2.73	3	3.24	2	22.03	5	21.79	7	7.5	2	3.8
Fletcher-Powell Conjugate Gradient	1.82	1	5.95	6	21.07	3	22.39	8	8.43	3	4.2
Polak-Ribiere Conjugate Gradient	2.27	2	2.16	1	18.93	1	18.51	3	9.55	6	2.6
One Step Secant	1.82	1	4.86	5	22.78	6	17.61	2	8.82	4	3.6
Gradient descent with momentum and adaptive learning	1.82	1	4.86	5	22.89	7	21.49	6	28.78	9	5.6

Table 4. Minimum errors for the above-set tasks will be the following:

No.	Name of data set	Minimum error in classification	Minimum number of neurons in hidden layers	Algorithm
1.	Wine	1,82	8	Gradient Descent Backpropagation with adaptive learning
			16	One Step Secant
			32	Fletcher-Powell Conjugate Gradient
2.	Iris	2.16	2	Levenberg-Marquart
			8	Polak-Ribiere Conjugate Gradient
3.	Spambase	6.89	32	Levenberg-Marquart
4.	SPECTTF Heart	16.12	8	Resilient Backpropagation
5.	Blood Transfusion	18.93	32	Polak-Ribiere Conjugate Gradient

In this respect we will deduce that training algorithms and selection of neural network architecture have relationships with each other in classification tasks solution made with neural networks application. This, in turn, results in reduction of errors at classification.

Polak-Ribiere Conjugate Gradient algorithm has given the most effective solution for the selected tasks. And Levenberg-Marquardt and the Resilient Backpropagation algorithms have been the most effective for large content learning samples.

References:

1. Jeaf Heaton. "Introduction to Neural Networks with Java". Heaton Research inc. St. Louis – 2005. – P. 77–104.
2. Аксенов С. В., Новоцелцов В. Б. "Организация и использование нейронных сетей (методы и технологии)". – Tomsk – 2006. – P. 16–21 p.
3. Simon Haykin. "Neural Networks and Learning Machines". 3rd edition. – 2009 y. – P. 80–95.
4. Howard Demuth, Mark Beale. "Neural Network Toolbox, User's Guide.
5. Осовский С. "Нейронные сети для обработки информации". – Moscow. – 2002. – P. 50–65.

Section 5. Mathematics

Stepanov Vasily Innokentievich,
East China Normal University,
Ph.D., student, School of Mathematical Sciences
E-mail: vis88@mail.ru

Ni Mingkang,
doctor, of Mathematics Prof.,
School of Mathematical Sciences
East China Normal University,

SECOND ORDER QUASI-LINEAR SINGULAR PERTURBED PROBLEM WITH NEUMANN BOUNDARY CONDITIONS AND DISCONTINUOUS TERM

Abstract: Using boundary functions method in combination with the method of sewing connection proved the existence of a solution and constructed its asymptotic expansion for 2nd order quasi-linear system with Neumann boundary conditions and discontinuous term.

Keywords: singular perturbed problem, boundary functions method, Neumann conditions, asymptotic solution.

1. Introduction

This paper devoted to the illustration of boundary functions method [1, 4] application to the solution of singularly perturbed problems on the example of 2nd order quasi-linear system with Neumann boundary conditions and discontinuous term using sewing connection as it is described in [2]. Using approach proposed by Vasil'eva A.B. in [3, 4] proved the existence of a solution and constructed its asymptotic representation and formulated theorem for solving the singularly perturbed problem given in the paper.

2. Formulation of Problem

Considered following Neumann boundary value problem

$$\begin{cases} \mu y'' = A(y, t)y' + f(y, t), & 0 \leq t \leq 1, \\ y'(0, \mu) = y^0, \quad y'(1, \mu) = y^1, \end{cases} \quad (1)$$

where

$$A(y, t) = \begin{cases} A^{(-)}(y, t), & 0 \leq t \leq t_0, \\ A^{(+)}(y, t), & t_0 < t \leq 1, \end{cases} \quad (2)$$

$$f(y, t) = \begin{cases} f^{(-)}(y, t), & 0 \leq t \leq t_0, \\ f^{(+)}(y, t), & t_0 < t \leq 1. \end{cases} \quad (3)$$

System (1.1) modified into the following form.

$$\begin{cases} \mu z' = A(y, t)z + f(y, t), \quad z = \frac{dy}{dt}, \\ z(0, \mu) = y^0, \quad z(1, \mu) = y^1, \end{cases} \quad (4)$$

where μ is a small parameter, t_0 is known point, y is a scalar function, $f(y, t)$ sufficiently smooth enough function. In this paper, considered the particular case when so called contrast structure occurred [5, 6]. Solution of such problem is a step-like contrast structure with a spike at the point t_0 and due to discontinuity of $A(y, t)$ and $f(y, t)$ functions.

The solution of described above problem constructed in the following form of function, which satisfies the initial system (1).

3. Main Assumptions

In order to solve stated above singularly perturbed problem, it is required to hold following assumptions.

Assumption 1. Functions $A(y,t)$ and $f(y,t)$ are discontinuous at point $t = t_0$. Thus, it is required to satisfy following inequalities at the discontinuity point.

$$\begin{aligned} A^{(-)}(y,t_0) &\neq A^{(+)}(y,t_0), \quad y \in I_y, \\ f^{(-)}(y,t_0) &\neq f^{(+)}(y,t_0), \quad y \in I_y. \end{aligned}$$

Assumption 2. Degenerate equations

$$\begin{cases} A^{(\mp)}(y,t)y' + f^{(\mp)}(y,t), & 0 \leq t \leq t_0, \\ y'(0,\mu) = y^0, \quad y'(1,\mu) = y^1. \end{cases} \quad (5)$$

Have isolated roots $\varphi_1(t)$ on the interval $[0, t_0]$, and $\varphi_2(t)$ on the interval $[t_0, 1]$. In order to be more precise, here we assumed that $\varphi_1(t_0) < \varphi_2(t_0)$.

Assumption 3. The condition of internal transitional layer existence at the transitional point $t = t_0$.

$$\begin{cases} A^{(-)}(y,t) > 0, & 0 \leq t \leq t_0, \\ A^{(+)}(y,t) < 0, & t_0 \leq t \leq 1. \end{cases} \quad (6)$$

Here, constructed a solution of the problem (1), with a discontinuity at point $t = t_0$.

$$t_0(\mu) = \bar{t}_0 + \mu \bar{t}_1 + \dots + \mu^n \bar{t}_n + \dots$$

Introduced following substitution of variable and used it for the initial equation in the following form:

$$\begin{cases} \mu z' = A^{(\mp)}(y,t)z + f^{(\mp)}(y,t), & \frac{dy}{dt} = z, \\ y'(0,\mu) = y^0, \quad y'(1,\mu) = y^1. \end{cases} \quad (7)$$

A new variable introduced:

$$z(t_0, \mu) = \frac{z_{-1}}{\mu} + z_0 + \dots + \mu^n z_n + \dots, \quad y(t_0) = y_0, \quad (8)$$

where y_0, z_i are unknown yet. Its values will be determined and calculated while the process of asymptotic expansion construction.

Asymptotic expansion of the problem (1.7) constructed in the following form.

$$\begin{aligned} y(t, \mu) &= \bar{y}(t, \mu) + Q^{(\mp)}y(\xi, \mu), \\ z(t, \mu) &= \bar{z}(t, \mu) + Q^{(\mp)}z(\xi, \mu), \end{aligned} \quad (9)$$

where $\xi = \frac{t-t_0}{\mu}$ and

$$\bar{y}(t, \mu) = \bar{y}_0(t) + \mu \bar{y}_1(t) + \dots + \mu^n \bar{y}_n + \dots, \quad (10)$$

$$\bar{z}(t, \mu) = \bar{z}_0(t) + \mu \bar{z}_1(t) + \dots + \mu^n \bar{z}_n + \dots,$$

is a regular part of asymptotic expansion.

$$\begin{aligned} Q^{(\mp)}y(\xi, \mu) &= Q_0^{(\mp)}y(\xi) + \mu Q_1^{(\mp)}y(\xi) + \dots + \\ &+ \mu^n Q_n^{(\mp)}y(\xi) + \dots, \end{aligned} \quad (11)$$

$$Q^{(\mp)}z(\xi, \mu) = \mu^{-1}Q_{-1}^{(\mp)}z(\xi) + z_0(\xi) + \dots +$$

$$+ \mu^n Q_n^{(\mp)}z_n(\xi) + \dots,$$

Series describe boundary layer in the neighborhood of t_0 point.

Assumption 4. On the phase plane (\tilde{y}, \tilde{z}) . Vertical line $\tilde{y} = y^{0,1}$, intersect separatrix Ω . This means, that

$$\int_{\varphi_1(0)}^{\tilde{y}} f(s,0,0)ds > 0, \quad \int_{\varphi_2(1)}^{\tilde{y}} f(s,1,0)ds > 0 \quad \text{for any } \tilde{y} \in (\varphi_1(t), \varphi_2(t)).$$

4. Construction of Formal Asymptotic

For simplifying construction asymptotic solution of the initial problem, two auxiliary problems introduced:

Left boundary value problem on the interval $[0, t_0]$

$$\begin{cases} \mu y'' = A^{(-)}(y,t)y' + f^{(-)}(y,t), & 0 \leq t \leq t_0, \\ y'(0,\mu) = y^0, \quad y(t_0, \mu) = p(\mu). \end{cases} \quad (12)$$

Right boundary value problem on the interval $[t_0, 1]$

$$\begin{cases} \mu y'' = A^{(+)}(y,t)y' + f^{(+)}(y,t), & t_0 \leq t \leq 1, \\ y(t_0, \mu) = p(\mu), \quad y'(1, \mu) = y^1. \end{cases} \quad (13)$$

Function $p(\mu)$ defined while the process of asymptotic expansion coefficients calculation. It defined in the form Taylor series with the power of expansion μ .

$$p(\mu) = p_0 + \mu p_1 + \dots + \mu^n p_n + \dots$$

5. Calculation of Regular and Boundary Layer's Asymptotic Coefficients

New variable substitution introduced $z = \frac{dy}{dt}$, as the result equivalent system to the system (12) obtained.

$$\begin{cases} \mu \frac{dz}{dt} = A^{(-)}(y,t)z + f^{(-)}(y,t), \\ y'(0, \mu) = y^0, \quad y(t_0, \mu) = p(\mu), \\ z(t_0, \mu) = \frac{z_{-1}^{(-)}}{\mu} + z_0^{(-)} = \dots \end{cases} \quad (14)$$

Formal solution of the problem (12) on the interval where $t \in [0, t_0]$ constructed in the following form.

$$y^{(-)}(t, \mu) = \bar{y}^{(-)}(t, \mu) + Q^{(-)}y(\xi, \mu), \quad (15)$$

$$z^{(-)}(t, \mu) = \bar{z}^{(-)}(t, \mu) + Q^{(-)}z(\xi, \mu), \quad (16)$$

where

$$\begin{aligned} \bar{y}^{(-)}(t, \mu) &= \bar{y}_0^{(-)}(t) + \mu \bar{y}_1^{(-)}(t) + \mu^2 \bar{y}_2^{(-)}(t) + \dots + \\ &+ \mu^k \bar{y}_k^{(-)}(t) + \dots, \end{aligned}$$

$$\begin{aligned} Q^{(-)}y(t, \mu) &= Q_0^{(-)}y(\xi) + \mu Q_1^{(-)}y(\xi) + \dots + \\ &+ \mu^k Q_k^{(-)}y(\xi) + \dots, \end{aligned}$$

$$\bar{z}^{(-)}(t, \mu) = \bar{z}_0^{(-)}(t) + \mu \bar{z}_1^{(-)}(t) + \dots + \mu^k \bar{z}_k^{(-)}(t) + \dots,$$

$$Q^{(-)}z(t, \mu) = \frac{Q_{-1}^{(-)}z(\xi)}{\mu} + Q_0^{(-)}z(\xi) + \mu Q_1^{(-)}z(\xi) + \dots + \mu^k Q_k^{(-)}z(\xi) + \dots, \\ \xi = \frac{(t-t_0)}{\mu}.$$

Functions $\bar{y}_k^{(-)}(t, \mu)$ and $\bar{z}_k^{(-)}(t, \mu)$ considered as regular parts of the asymptotic expansion of the problem's solution. Functions $Q_k^{(-)}y(t, \mu)$ and $Q_k^{(-)}z(t, \mu)$ series represent a transitional layer in the neighborhood of transitional point $t = t_0$. It is necessary to mention that series represented transitional layer must satisfy the following condition $Q_k^{(-)}(-\infty) = 0$.

In a similar way constructed a formal solution of the right-side boundary value problem (13).

$$y^{(+)}(t, \mu) = \bar{y}^{(+)}(t, \mu) + Q^{(+)}y(\xi, \mu). \quad (17)$$

$$z^{(+)}(t, \mu) = \bar{z}^{(+)}(t, \mu) + Q^{(+)}z(\xi, \mu). \quad (18)$$

Using a standard approach introduced in the boundary functions method lets insert equations (15–18) into the problems (12–13). Variables with the same power of t , ξ are separated and coefficients with the same power of μ will be equal to each other.

$$\frac{dQ^{(\mp)}z}{d\xi} = A^{(\mp)} \left[\bar{y}^{(\mp)}(t_0 + \xi\mu, \mu) + \bar{z}^{(\mp)}(t_0 + \xi\mu, \mu) + \right. \\ \left. Q^{(\mp)}y, t_0 + \xi\mu \right] + Q^{(\mp)}z \\ + f^{(\mp)}(\bar{y}(t_0 + \xi\mu, \mu) + Q^{(\mp)}z) - \\ - A^{(\mp)}(\bar{y}^{(\mp)}(t_0 + \xi\mu, \mu), t_0 + \xi\mu) \bar{z}^{(\mp)}(t_0 + \xi\mu, \mu) - \\ - f^{(\mp)}(\bar{y}^{(\mp)}(t_0 + \xi\mu, \mu), t_0 + \xi\mu), \quad (19)$$

$$\frac{dQ^{(\mp)}y}{d\xi} = \mu Q^{(\mp)}z, \quad Q^{(\mp)}z(\mp\infty) = 0, \quad Q^{(\mp)}y(\mp\infty) = 0,$$

where $t = t_0 + \xi\mu$.

Let us equate coefficients with the highest power (order μ^{-1} in (19) and order μ^0), following results, obtained.

In particular, for the main term of the regular part $\bar{y}_0^{(\mp)}(t)$ a solution of the degenerate equation,

$$\begin{cases} A^{(\mp)}(\bar{y}_0^{(\mp)}(t), t) \bar{z}_0^{(\mp)}(t) + f^{(\mp)}(\bar{y}_0^{(\mp)}(t), t) = 0, \\ \frac{d\bar{y}_k^{(\mp)}}{dt} = \bar{z}_k^{(\mp)}(t), \\ \bar{y}'_0(0) = y^0, \quad \bar{y}'_0(1) = y^1. \end{cases} \quad (20)$$

Then in case of $\bar{y}_k^{(\mp)}(t)$, where $k \geq 1$ following system of linear equations obtained.

$$\begin{cases} \frac{d\bar{z}_{k-1}^{(\mp)}}{dt} = A^{(\mp)}(\bar{y}_0^{(\mp)}, t) \bar{z}_k^{(\mp)}(\mu) + F^{(\mp)}(t), \\ \frac{d\bar{y}_k^{(\mp)}}{dt} = \bar{z}_k^{(\mp)}(t), \\ \bar{y}'_k(0) = 0, \end{cases} \quad (21)$$

where $F^{(\mp)}(t)$ is a function from $(\bar{y}_0^{(\mp)}, \bar{y}_1^{(\mp)}, \dots, \bar{y}_{k-1}^{(\mp)})$, $k \geq 1$.

From the theory of differential equations, it is known that linear differential equations are uniquely solvable. Thus, all of the coefficients of the regular part defined.

Internal transitional layer constructed using same standard approach. As the result, following system obtained.

$$\begin{cases} \frac{dQ_{-1}^{(\mp)}z}{d\xi} = A^{(\mp)}(\varphi_i(t_0) + Q_0^{(\mp)}y, t_0) Q_{-1}^{(\mp)}z, \\ \frac{dQ_0^{(\mp)}y}{d\xi} = Q_{-1}^{(\mp)}z, \\ Q_{-1}^{(\mp)}z(\mp\infty) = 0, \quad Q_0^{(\mp)}y(\pm\infty) = 0, \\ Q_{-1}^{(\mp)}z(0) = z_{-1}^{(\mp)} - \bar{z}^{(\mp)}(t_0), \quad Q_0^{(\mp)}y(0) = p_0 - \varphi_i(t_0). \end{cases} \quad (22)$$

A new variable introduced and substitution operation result would be $\tilde{y}_0^{(\mp)} = \varphi_i(t_0) + Q_0^{(\mp)}y(\xi)$ and $\tilde{z}_{-1}^{(\mp)} = \tilde{y}_0^{(\mp)}$, then as the result obtained modified system.

$$\begin{cases} \frac{d\tilde{z}_{-1}^{(\mp)}}{d\tilde{y}_0^{(\mp)}} = A^{(\mp)}(\tilde{y}_0^{(\mp)}, t_0), \\ \tilde{z}_1^{(\mp)}(\mp\infty) = 0, \quad \tilde{y}_0^{(\mp)}(\mp\infty) = \varphi_i(t_0), \\ \tilde{z}_{-1}^{(\mp)}z(0) = \tilde{z}_{-1}^{(\mp)}, \quad \tilde{y}_0^{(\mp)} = p_0. \end{cases} \quad (23)$$

Equation (23) contains differential equations with a separable variable. Using assumptions 2–4 obtained.

$$\frac{d\tilde{y}_0^{(\mp)}}{d\xi} = \tilde{z}_{-1}^{(\mp)} = \int_{\varphi_i(t_0)}^{\bar{y}} A^{(\mp)}(s, t_0) ds,$$

$$z_{-1}^{(\mp)} = \int_{\varphi_i(t_0)}^{p_0} A^{(\mp)}(s, t_0) ds.$$

From there it is not difficult to see, that $Q_0^{(\mp)}y(\xi) = \tilde{y}_0^{(\mp)}(\xi) - \varphi_i(t_0)$.

Let us define other coefficients of asymptotic expansion $(Q_k^{(\mp)}y(\xi), Q_{k-1}^{(\mp)}z(\xi))$, where $k \geq 1$. As the result, following system of equations obtained.

$$\left\{ \begin{aligned} \frac{dQ_{k-1}^{(\mp)}z}{d\xi} &= A^{(\mp)}(\xi)Q_{k-1}^{(\mp)}z + A_y^{(\mp)}(\xi)Q_{-1}^{(\mp)}zQ_k^{(\mp)}y + G_{k-1}^{(\mp)}(\xi), \\ \frac{dQ_k^{(\mp)}y}{d\xi} &= Q_{k-1}^{(\mp)}z, \\ Q_{k-1}^{(\mp)}z(\mp\infty) &= 0, \quad Q_k^{(\mp)}y(\pm\infty) = 0, \\ Q_{k-1}^{(\mp)}z(0) &= z_{k-1}^{(\mp)}, \quad Q_k^{(\mp)}y(0) = p_k - \bar{y}(t_0). \end{aligned} \right. \quad (24)$$

where $G_{k-1}^{(\mp)}(\xi)$ is a known function, $A^{(\mp)}(\xi)$, $A_y^{(\mp)}$ calculated at the point $(\varphi_i(t_0) + Q_0^{(\mp)}y, 0)$.

Notice that function contains unknown p_k . In order to define and calculate unknown coefficients, the condition of asymptotic expansion derivative equality for the problem (12) at the point $t = t_0$ used.

$$y'^{(-)}(t_0, \mu) = y'^{(+)}(t_0, \mu)$$

Takin into account that,

$$z'^{(-)}(t_0, \mu) = z'^{(+)}(t_0, \mu) \quad (25)$$

At first, defined and calculated p_0 . In approximation of μ^{-1} , condition (25) rewritten into the next form.

$$Q_{-1}^{(-)}z(0) = Q_{-1}^{(+)}z(0). \quad (26)$$

In order to solve introduced above problem, assume that

$$H(p) = \int_{\varphi_1(t_0)}^p A^{(-)}(s, t_0) ds - \int_{\varphi_2(t_0)}^p A^{(+)}(s, t_0) ds. \quad (27)$$

Next step is to verify the uniqueness of the described above equation's solution $p_0 \in (\varphi_1(t_0), \varphi_2(t_0))$.

Thus,

$$\begin{aligned} H(\varphi_1(t_0))H(\varphi_2(t_0)) &= \\ &= \int_{\varphi_1(t_0)}^{\varphi_2(t_0)} A^{(-)}(s, t_0) ds \times \int_{\varphi_1(t_0)}^{\varphi_2(t_0)} A^{(+)}(s, t_0) ds. \end{aligned} \quad (28)$$

$$p_k = \frac{\left[\bar{z}_k^{(+)}(t_0) - \bar{z}_k^{(-)}(t_0) + A^{(-)}(p_0, t_0)\bar{y}_k^{(-)}(t_0) - A^{(+)}(p_0, t_0)\bar{y}_k^{(+)}(t_0) \right]}{\left(A^{(-)}(p_0, t_0) - A^{(+)}(p_0, t_0) \right)} + \frac{\int_{\varphi_1(t_0)}^{\varphi_2(t_0)} G^{(+)}(s, t_0) ds - \int_{\varphi_1(t_0)}^{\varphi_2(t_0)} G^{(-)}(s, t_0) ds}{\left(A^{(-)}(p_0, t_0) - A^{(+)}(p_0, t_0) \right)} \quad (33)$$

Thus, in case of sufficient smoothness, it is possible to define and calculate all of the asymptotic expansion's coefficients for the function $Q_k^{(\mp)}y(\xi)$, $Q_k^{(\mp)}z(\xi)$ for any.

6. The Existence of Asymptotic Solution

$$y(t, \mu) = \begin{cases} \sum_{k=0}^{n+1} \mu^k \left[\bar{y}_k^{(-)} + Q_k^{(-)}y(\xi) \right] + O(\mu^{n+2}), & 0 \leq t \leq t_0, \\ \sum_{k=0}^{n+1} \mu^k \left[\bar{y}_k^{(+)} + Q_k^{(+)}y(\xi) \right] + O(\mu^{n+2}), & t_0 < t \leq 1. \end{cases} \quad (34)$$

From assumption 2, following inequality obtained.

$$H(\varphi_1(t_0))H(\varphi_2(t_0)) \leq 0. \quad (29)$$

Which means existence of $p_0 \in (\varphi_1(t_0), \varphi_2(t_0))$ such that $H(p_0) = 0$.

Thus, sequentially all of the p_k are defined and calculated, where $k \geq 1$. Following condition obtained as the result.

$$\bar{z}_k^{(-)}(t_0) + Q_{k-1}^{(-)}z(0) = \bar{z}_k^{(+)}(t_0) + Q_{k-1}^{(+)}z(0). \quad (30)$$

Taking into account, that

$$\begin{aligned} \frac{d(A^{(\mp)}Q_k^{(\mp)}y)}{d\xi} &= A^{(\mp)}(\xi) \frac{dQ_k^{(\mp)}y}{d\xi} + \\ &+ A_y^{(\mp)}(\xi) \frac{d(\varphi_i(t_0) + Q_0^{(\mp)})}{d\xi} Q_k^{(\mp)}y = \\ &= A^{(\mp)}(\xi)Q_{k-1}^{(\mp)}z + A_y^{(\mp)}(\xi)Q_{-1}^{(\mp)}zQ_k^{(\mp)}y \end{aligned} \quad (31)$$

Obtained,

$$\frac{dQ_{k-1}^{(\mp)}z}{d\xi} = \frac{d(A^{(\mp)}Q_k^{(\mp)}y)}{d\xi} + G_{k-1}^{(\mp)}(\xi). \quad (32)$$

By applying integration to the last equation and taking into consideration boundary conditions, obtained next equation.

$$Q_{k-1}^{(\mp)}z(\xi) = A^{(\mp)}Q_k^{(\mp)}y(\xi) + \int_{\mp\infty}^{\xi} G_{k-1}^{(\mp)}(s) ds.$$

By assuming $\xi = 0$, obtained following expression.

$$Q_{k-1}^{(\mp)}z(0) = A^{(\mp)}(p_0, t_0) \left(p_k - \bar{y}_k^{(\mp)}(t_0) \right) + \int_{\mp\infty}^0 G_{k-1}^{(\mp)}(s) ds.$$

A new substitution of the variable introduced $Q_{k-1}^{(\mp)}z(0)$ in (30). As the result, obtained equation for calculation p_k .

Theorem. If the assumptions 1–4 are holds and values of small parameter $\mu \geq 0$ sufficiently small enough, there exist smooth solution $y(t, \mu)$ for the boundary value problem (1), which has following asymptotic representation

Proof. It is known that partial sum of a k -order approximate solution of the initial problem (1) to the order up to $O(\mu^{k+1})$, and its derivatives up to $O(\mu^k)$ order. Substitute derivative solutions at the point t_0 for proving existence solution of the initial problem and its asymptotic expansion following auxiliary problems considered.

Let us consider first auxiliary problem on the interval $0 \leq t \leq t_0$.

$$\begin{cases} \mu y^{(-)} = A^{(-)}(y, t)y^{(-)} + f^{(-)}(y^{(-)}, t), & 0 \leq t \leq t_0, \\ y^{(-)}(0, \mu) = y^0, \quad y^{(-)}(t_0, \mu) = \bar{p}(\mu), \end{cases} \quad (35)$$

where $\bar{p}(\mu) = p_0 + \mu p_1 + \dots + \mu^{n+1}(p_{n+1} + \delta)$, δ is a parameter.

Next step is to consider the similar problem on the interval $0 \leq t \leq t_0$.

$$\begin{cases} \mu y^{(+)} = A^{(+)}(y, t)y^{(+)} + f^{(+)}(y^{(+)}, t), & t_0 \leq t \leq 1, \\ y^{(+)}(t_0, \mu) = \bar{p}(\mu), \quad y^{(+)}(1, \mu) = y^1. \end{cases} \quad (36)$$

As mentioned previously every auxiliary problem given above has a solution $y^{(-)}(t, \mu)$ and $y^{(+)}(t, \mu)$ that represented in the following forms.

$$y^{(-)}(t, \mu) = \sum_{k=0}^{n+1} \mu^k \left[\bar{y}_k^{(-)}(t) + Q_k^{(-)} y(\xi) \right] + O(\mu^{n+2}), \quad (37)$$

where $\xi = \frac{t-t_0}{\mu}$.

$$y^{(+)}(t, \mu) = \sum_{k=0}^{n+1} \mu^k \left[\bar{y}_k^{(+)}(t) + Q_k^{(+)} y(\xi) \right] + O(\mu^{n+2}). \quad (38)$$

If the derivatives of these functions have the same value at the point $t = t_0$, then these functions are solutions for the initial problem (1).

Here given a demonstration that \bar{p} can be chose and satisfy following conditions.

$$\frac{du^{(-)}}{dt}(t_0, \mu) = \frac{du^{(+)}}{dt}(t_0, \mu). \quad (39)$$

Let us assume that,

$$I(\bar{p}, \mu) = \frac{dy^{(-)}}{dt}(t_0, \mu) - \frac{dy^{(+)}}{dt}(t_0, \mu). \quad (40)$$

From already described previously asymptotic expansion and derivatives equality condition concluded result.

$$\begin{aligned} I(\bar{p}, \mu) = & \mu^{n+1} \left(\bar{z}_n^{(-)}(t_0) + Q_n^{(-)} - \bar{z}_n^{(+)}(t_0) - Q_n^{(+)} z(0) \right) + \\ & + Q(\mu^{n+1}) = \mu^{n+1} \left[\delta \left(A^{(-)}(p_0, t_0) - A^{(+)}(p_0, t_0) \right) \right] \end{aligned} \quad (41)$$

From the equation above it is known, that there exists $\delta = \delta_*$ such that $I(\delta_*, \mu) = 0$. Thus, obtained smooth solution $y(t, \mu)$ of initial problem (1).

References:

1. Butuzov V.F. Asymptotic methods in singularly perturbed problems. Yaroslavl – 2014. – 108 p.
2. Ni Mingkang, Gurman V.I. Sewing connection of step-step solution for singularly perturbed problems. J. Math. Research with Appl. – 2012. – Vol. 32. – No 1. – P. 26 – 32.
3. Vasil'eva A. B. On a system of two singularly perturbed second order quasilinear equations. J. Vychisl. Mat. Mat. Fiz., – Vol. 44. – No 4. – 2004. – P. 650–661.
4. Vasil'eva A. B., Butuzov V.F. Asymptotic expansions of solutions of singularly perturbed equations. Nauka, Moscow – 1973. – 272 p.
5. Vasil'eva A. B., Butuzov V.F., Nefedov N.N. Contrast structures in singularly perturbed problems. J. Fundamentalnaya i Prikladnaya Matematika, – Vol. 4. – No. 3. – 1998. – P. 779–851.
6. Vasil'eva A. B., Butuzov V.F., Nefedov N.N. Singularly perturbed problems with boundary and internal layers. J. Proceedings of the Steklov Institute of Mathematics, 268 (1). – 2010. – P. 258–273.

Section 6. Materials Science

*Ziyamukhamedova Umida Alijanovna,
professor, of a Tashkent State technical University*

*Bakirov Lutfillo Yuldoshaliyevich,
Scientific researcher, of a Tashkent State technical University*

*Miradullaeva Gavkhar Bakpulatovna,
Scientific researcher, of a Tashkent State technical University*

*Bektemirov Begali Shukhrat ugli,
Master of a Tashkent State technical University
E-mail: begalibektemirov94@gmail.com*

SOME SCIENTIFIC AND TECHNOLOGICAL PRINCIPLES OF DEVELOPMENT OF COMPOSITE POLYMER MATERIALS AND COATINGS OF THEM FORCOTTON MACHINE

Abstract: The article presents the results of experimental researches of influence of technological factors on the mechanical and performance properties heterogeneity polymeric materials using standard methods and devices. Examined and shows the changes of deformation properties and intergovernmental heterogeneity plasticization of polymeric materials from the content and type of filler, as well as the technological compatibility of their use. This borders the amount of use of fillers based on the explanation of the obtained experimental data.

Keyword: heterocomposite polymer materials (GKPM), roughness, glass transition temperature, plasticizer, filler, epoxy composition.

One of the most important mechanical properties of heterocomposite polymer materials heterogeneity (HCPM) are modules of elasticity and hardness, which depends on the adhesive and mechanical components' force of friction interaction. It is also important to provide a high uniformity of the micro hardness and sufficient electrical and thermal conductivity of the material. Typically, these properties HCPM are achieved with a very high content of fillers [1–3].

We carried out experiments to identify the influence of technological factors on the mechanical and operational properties HCPM using the standard method and devices [4, 5]. The results of the study showed that initial roughness HCPM practically does not depend on the content and filler dispersion, and the value of RZ is in

the range of 3–5 microns. And the roughness of the run-in surfaces significantly depends on the above factors. It depends on the friction of regime and physio-mechanical properties of HCPM when R_z increases from 10 to 25 microns; the highest growth of R_z is observed at a low content of the filler, due to the high uniformed micro-hardness of the HCPM at the expense of the uneven distribution of the filler particles in the composite. Thus, it is noted that the increase of R_z contributes to the increase of the friction coefficient (f) cotton with the surface of polymeric materials [2]. (Fig. 1) shows that the increase of the filler's content up to 20–43 of the masses.h. leads to more uniform distribution of the particles and to increase the mechanical (hardness) properties HCPM and, consequently, decrease of R_z and f . The increase of

f , and R_z at high filler content (30 mass.h and above for graphite; 35 mass.h. and above cement and kaolin) is associated with a decrease of the mechanical properties of epoxy composite at the expense of the deterioration of the technological characteristics HCPM forming.

The results of the study revealed, on the one hand, the inadvisability of creating HCPM with less solid content of the fillers than 20–30 mass.h., on the other

hand – there was a limit to the technological compatibility of the filler with a binder which deteriorates not only the adaptability of obtaining HCPM, but significantly reduced their mechanical properties. It should be noted that technological compatibility and contrast the “critical amount of content” depends not only on the amount of filler, but also on its nature and properties.

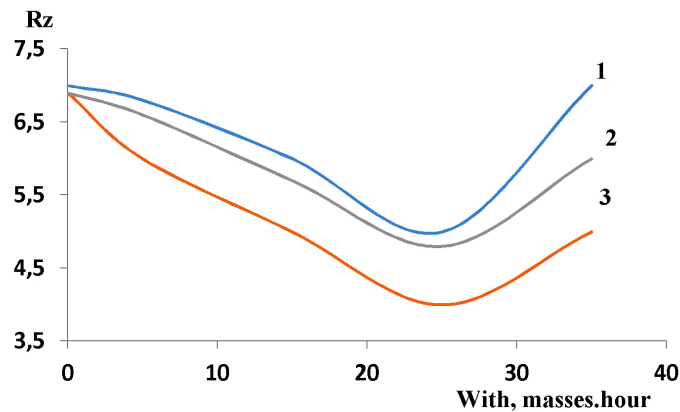

Figure 1. The effect of filler content on the roughness of surface HCPM. 1 – graphite; 2 – concrete; 3 – kaolin

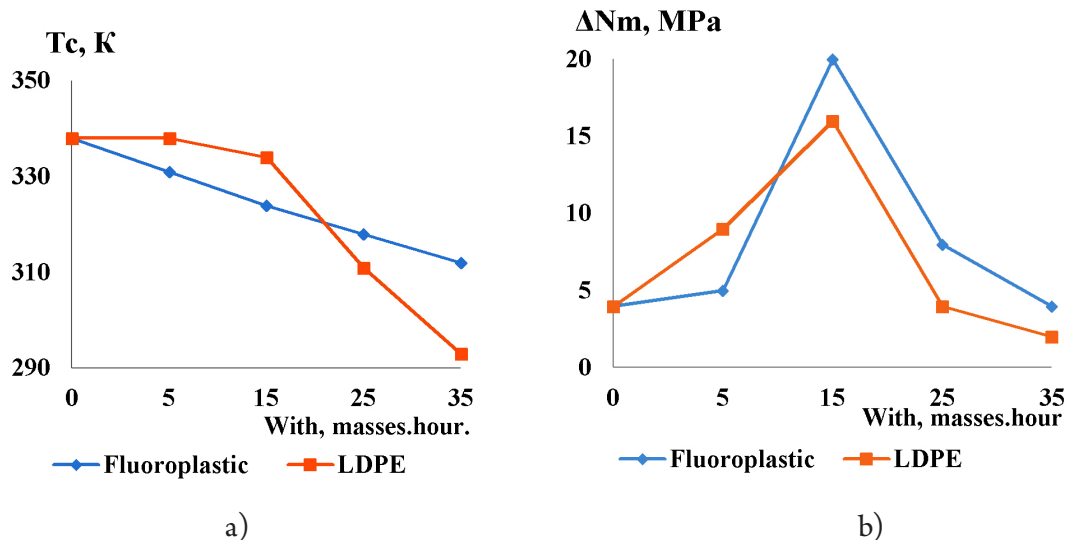

Figure 2. The influence of the fluoroplastic content and polyethylene on temperature glass transition (T_g) and strength (ΔN) HCPM on the basis of ED-16

One of the most versatile and effective methods of evaluating the technological compatibility of the fillers and binders, in our opinion, is the glass transition temperature, determined by thermomechanical scales [6]. Since, *ceteris paribus* HCPM mechanical properties, especially hardness and elastic modulus, proportional to the temperature of their glass transition. However, it should be noted that the term “glass transition tempera-

ture” for HCPM in the literature is not met. Since the glass transition temperature determines the deformation properties of the material and connected with the mobility segments of macromolecules, then its value can be judged on confirmation changes in the interfacial layer of polymer-filler compatibility.

From the results of research the various contents influence of fillers on the glass transition temperature

HCPM on the basis of ED-16 (Fig. 2) it can be seen that with increasing content of organic fillers (fluoroplastic and polyethylene) in the polymer composition decreases the glass transition temperature. For example, the introduction of these fillers in an amount of 30 mass.h. reduces the temperature-glass transition till 15–18 ° C. This is apparently due to the fact that the inactive filler Teflon and polyethylene in epoxy compositions do not act chemically and form a mesh structure.

Increasing the amount of these fillers till 20–40 masses.h. reduces the TC of the polymer composition is straightforward, which is due to the spatial attenuation of the epoxy cross-linking and the difficulty of structure formation full process.

When developing HPCM, mechanical engineering is traditionally used, for example, asbestos, cement and kaolin are the active mineral fillers, and are widely used to improve the mechanical properties of various polymer compositions.

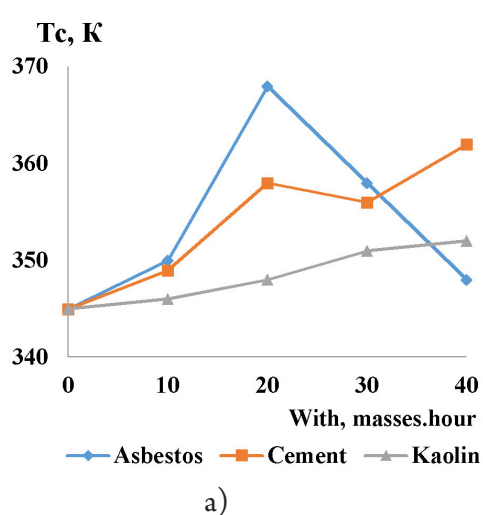

From (Fig. 3) it can be seen that at low content of asbestos (up to 10 masses.h.) significantly increasing the glass transition temperature, and subsequent grades there has been some reduction in it. Similar, but less effective increase is observed with the introduction of the cement. With the introduction of kaolin (up to 20 masses.h.) there is a slight increase in the glass transition temperature and subsequent values (up to 30–40 mass.h.) observed natural decline. Despite the almost identical chemical composition of asbestos, cement and kaolin, there are significantly different effects during the filling. In one case, the effect of interstructural filling and the other with the effect of interstructural plasticization [6]. The physical structure of fillers becomes clear. Asbestos, because of its fibrous nature, increases the strength HCPM, and kaolin, due to the layered structure plays the role of plasticizer. An intermediate position is cement with explicit interphase structural effect causing a high glass transition temperature and thus the strength properties HCPM.

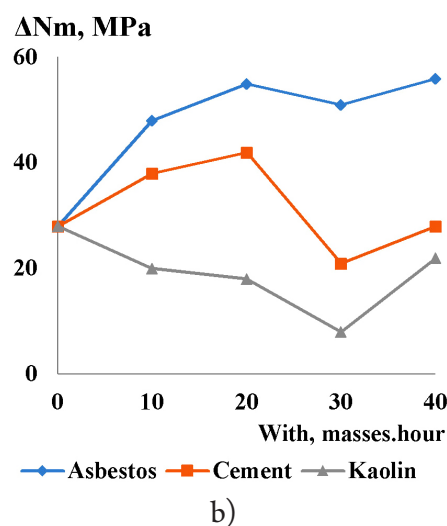

Figure 3. The influence of asbestos, cement and kaolin content in the temperature glass transition (T_g) and strength (ΔN) HCPM on the basis of ED-16

There is a concept of realization of the effect of interstructural plasticizing fillers, of lamellar structure [2, 6], which is clearly seen when comparing the glass transition temperature HCPM filled with granular graphite and lamellar (scaly) structure.

The glass transition temperature HCPM, graphite-filled leaf shaped, somewhat less even than that of the unfilled epoxy composite. With the introduction of the aluminum powder, powders of copper and iron TC increases (Fig.4 and Fig.5). This is because the introduction in the polymeric composition of the active metallic

fillers leads to a reorientation of unrelated and have sufficient mobility of polymer chains, with formation of more structured (compared to empty) polymer structure. At sufficiently high concentrations of the metal fraction in direct contact increases, consequently, decreases the mobility and speed of polymer order. The highest TC is observed when filling the iron powder.

Active surface of iron dispersed at low concentrations contributes to the orientation and ordering of the polymer along with grafting to macromolecules, and the high content prevailing chemical interaction

with a decrease in the mobility of full-length chains at the interface of the binder active filler, which leads to a gradual increase in the glass transition temperature of the composition. In the polymerization of epoxy resin

in the presence of fillers such as iron, copper and aluminum there is a transfer of electrons to the surface metal atoms the polymer molecule with the formation of active particles of the ion-radical [1–3].

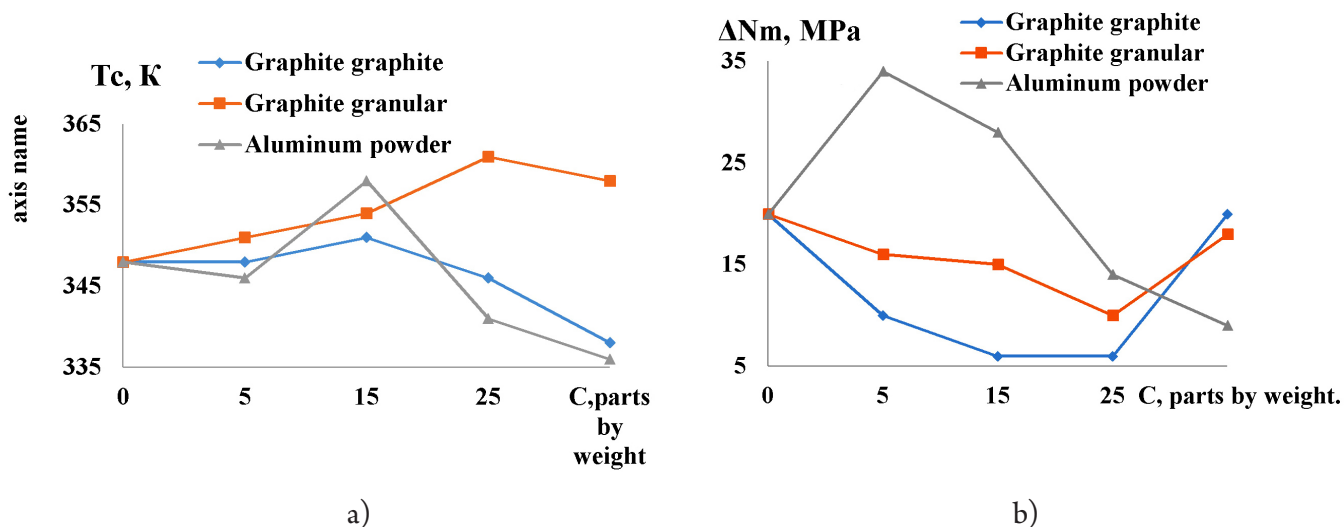

Figure 4. The influence of graphite content (lamellar and granular), aluminum dust on the Vehicle (glass transition temperature) and ΔN (strength) HCPM on the basis of ED-16

Such a compound formed of the polymer with solid surfaces is possible only in case of stable chemical formation bonding of the disperse inorganic substances with the carbon atoms of the polymer chain. As can be seen from the above, the formation of strong linkages of the polymer with the filler can occur simultaneously with a substantial improvement of physio-mechanical properties, characterized by a change in the glass transition temperature HCPM [2, 3].

It should be noted that when creating HCPM with high strength characteristics are the most effective fillers of fibrous type having a reinforcing effect. Significantly increases the wear resistance of the PCM when filled with glass fiber, available high glass transition temperature, according to our research, also points to the effectiveness of fillers reinforcing nature.

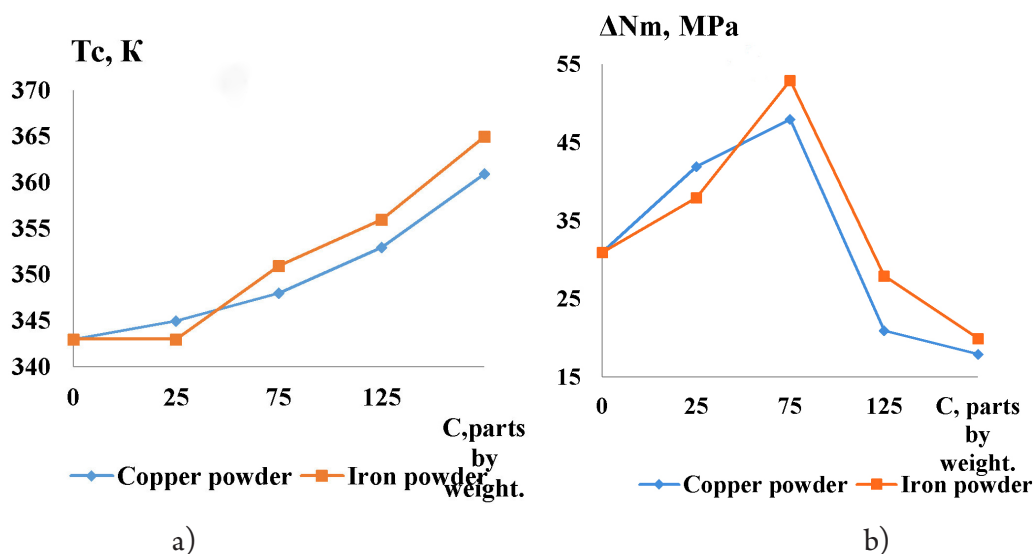
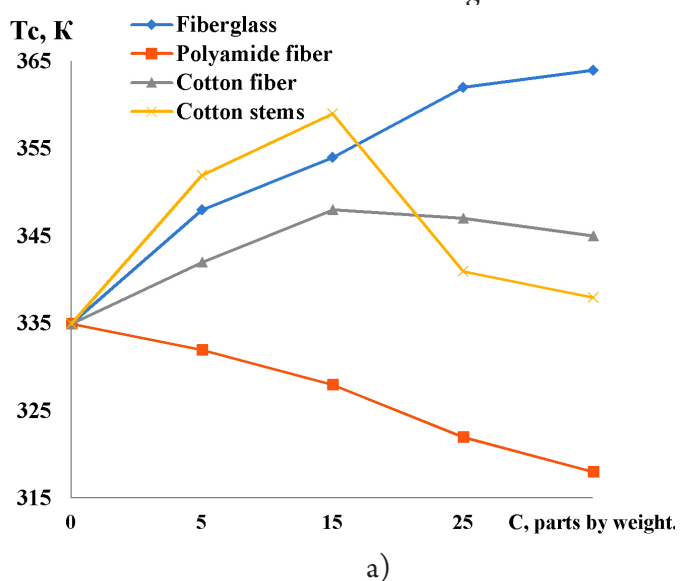

Figure 5. The influence of copper and iron powder content on the Vehicle (glass transition temperature) and ΔN (strength) HCPM on the basis of ED-16

However, as noted above, rigid fibrous fillers (asbestos and fiberglass) lead to a substantial increase of the mechanical damage of cotton.

From Fig.6 shows that the highest glass transition temperature is observed with the introduction of short cotton fibers are purified from the wax layer. Intermediate position has chopped cotton stalks and cotton fibers with the wax (pectin) layer, and the lowest glass transition temperature – HCPM filled polyamide fiber.

On the basis of these results, as well as the structural characteristics and surface state of the fillers can be assumed that between the reinforcing cellulose fiber



and epoxy resin possible chemical interaction with the formation of ether bonds. Hydroxyl groups of cellulose are capable of forming a chemical bond with the epoxy group in the emergence of three-dimensional reticulated structure. This chemical structure also limits the flexibility of the polymer chains and the sliding of the macromolecules. It is easy to see when comparing the glass transition temperature HCPM on the basis of epoxy, filled with cotton fiber with different surface. Pectin layer on the surface of the cotton fiber plays the role of the interfacial plasticization of the macromolecules of the polymer, resulting in a somewhat reduced TC HCPM.

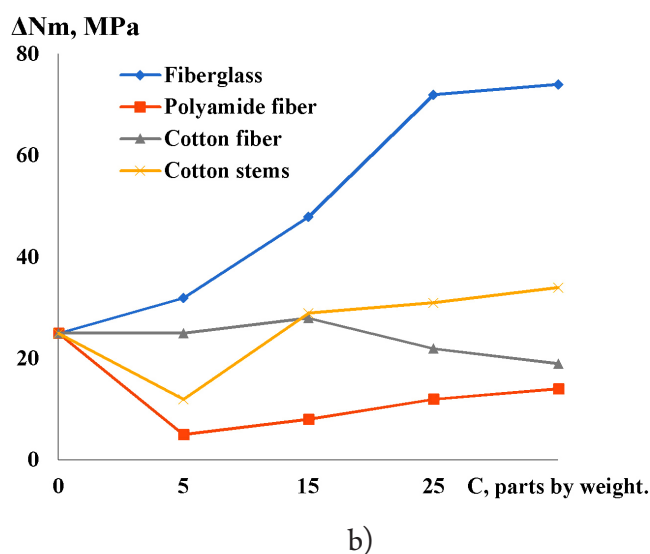

Figure 6. The influence of glass fiber content, polyamide fiber, cotton fibers and stalks of the cotton plant on the glass transition temperature (TC) and strength (ΔN) HCPM on the basis of ED-16

A slight decrease in TC with the introduction of polyamide fibers connect with the structure of polymeric filler, high mobility of macromolecules of polyamide due to the side hydroxyl and amide groups [3]. In addition, a high glass transition temperature epoxy CPM filled with chopped stalks of cotton, and activated the surface of cotton fibers can be explained by diffusion processes in the interfacial layer when the reinforcing filler is in the oriented state and has the micro pores of the filler. As the filling of voids of the reinforcing filler epoxy resin is effective hardening in the interface layer, the filler – binder. Observed phenomenon is analogous to the interfacial structure, reduces mobility of macromolecules and increases the rigidity of HCPM.

Thus, it can be noted that the glass transition temperature HCPM is the most universal characteristics to assess the strength and thermomechanical properties of polymers; it can be used to assess technological compatibility of the binder and filler, simultaneously estimating the uniformity of the microhardness of the surface HCPM depending on the type and content of filler.

It should be emphasized that the influence of fillers portage-necessary nature on the mechanical properties HCPM stronger than that of dispersed fillers due to the high uneven distribution of fillers in the amount of HCPM. In addition, the introduction of fibrous fillers significantly worsens the adaptability of obtaining HCPM due to increasing the viscosity of the compositions.

References:

1. White V.A., Yurkevich O.R., Dovialov V.A. Thin-layer polymer coatings.– Minsk, Science and Technology,– 1976.– 416 p.
2. Lipatov Yu. S. Physical Chemistry of Filled Polymers.– M: Chemistry,– 1977.– 304 p.
3. Nilsen L. Mechanical properties of polymers and polymer composites.– M: Chemistry,– 1978.– 310 p. 4. FAP 00782 Disk Tribometer /Dzhumabaev, A. B. etc. // RA AIS No. 122012.– P. 79–80.
4. O'zDSt 2822–2014 / – 29 p.
5. Dzhumabaev A. B. Friction and damage of the cotton // NII. The Agency “Uzstandard”.– Tashkent,– 2011.– 275 p.

Section 7. Medicine

*Astanakulova Munisa Mirzoyevna,
assistant, of department of faculty therapeutic dentistry
Tashkent State Dental Institute teacher,
E-mail: munisa.suyunova@mail.ru*

*Bekjanova Olga Esenovna,
department faculty therapeutic dentistry, professor, d.m.s.(DSc)
Tashkent State Dental Institute head of
E-mail: bekjanovaolga@mail.ru*

THE ROLE OF CYTOKINES IN THE PATHOGENESIS OF EXFOLIATIVE HEALITY

Abstract: Scientific review dedicated to the study of the cytokine status is of fundamental importance for determining not only the severity, but also the nature of the inflammation. The solution of this question will allow to solve the most important pathogenetic mechanisms of pathology development.

Keywords: Exfoliative cheilitis – ECH, interleukin 1 – IL-1, interleukin 6 – IL-6, interleukin 4 – IL-4, interleukin 10 – IL-10, interferon gamma – IFN γ , necrosis factor t – FNO-*a*.

Exfoliative cheilitis (ECH) – (K13.02 according to МКБ-10) belongs to the group of the most frequent pathologies of the red border of the lips, characterized by polyethiologic, “blurred” clinical picture, persistent flow, short-term remissions. Persistent peeling of the outer surface of the lips is one of the main signs of this disorder. Additional symptoms of the disease may include ulceration of the lips, dry lips, discoloration of the lips, itching sensation on the affected lip, tingling sensation, discoloration. The form of clinical manifestations can vary from “dry”, characterized by the appearance of dry scales to “exudative”, in which formation of scaly crusts is observed on the red border of the lips [4, 60–61; 6, 485–489].

Despite the limited nature of the defeat, the complex multicomponent mechanism of development, flow and outcome of the ECH of the present time remains not fully understood.

Modern achievements in the field of studying immunoregulatory mechanisms suggest that cytokines

play the main role in activation and regulation of the immune response processes determining the severity and duration of the disease [1; 2, 655–660; 3, 60–61]. The study of the cytokine status is of fundamental importance for determining not only the severity, but also the nature of the inflammation. The solution of this question will allow to solve the most important pathogenetic mechanisms of pathology development.

The role of cytokines in the immunopathogenesis of exfoliative cheilitis has not been adequately studied at present, which has determined the purpose of our study: the study of the pathogenetic significance of some cytokines in patients with different clinical course of ECH.

Materials and methods. In accordance with the objectives of the study, 27 patients with different clinical forms of ECH were selected for the study, including 17 with “dry” and 10 with “exudative”; the average age of the examinees was 34.4 ± 1.25 years, 10 patients without pathology of the red border of the lips made up a comparison group. The comparison groups were randomized

according to the sex-age structure, as well as the frequency and severity of background somatic pathology.

To study the content of cytokines, we used oral fluid collected on an empty stomach, in the morning, without stimulation, and also venous blood taken from 8 to 10 am in plastic tubes BD Vacutainer ("BD Bioscience"). In the oral fluid, blood plasma by the method of enzyme immunoassay by means of appropriate test systems (Vector-Best, Russia), the content of pro- and anti-inflammatory cytokines was determined.

Statistical processing of data was carried out using a personal computer and a package of statistical programs "STATNISK-6". At all stages of the study, the arithmetic mean (M), the arithmetic mean error (m), the mean square error of the arithmetic mean (Sx), the reliability criterion (t) were determined. Differences between groups were considered statistically significant at $p < 0.05$.

Results and discussion. Analysis of the cytokine profile in patients revealed a significant increase in the levels of pro – and anti – inflammatory cytokines in both studied media. The degree of manifestation of the revealed changes was determined by the clinical form of the disease.

Thus, in patients with a "dry" form of the disease, the concentration of FNO- α in serum was increased by 48.59% ($P \leq 0.05$); IFN γ – by 42.52% ($P \leq 0.05$); IL-1 by 48.99% ($P \leq 0.05$) and IL-6 by 22.27% ($P \leq 0.05$); the corresponding dynamics in patients with "exudative" form was 114.60% ($P \leq 0.05$); 121.91% ($P \leq 0.05$); 78.18% ($P \leq 0.05$) and 85.43% ($P \leq 0.05$). It should be noted that in the oral fluid, an increase in the concentration of cytokines had a different directionality. At the same time, if in patients with a "dry" form the concentration of FNO- α in the blood serum was increased relative

to the control group by 26.71% ($P \leq 0.05$); IFN γ – by 27.45% ($P \leq 0.05$); IL-1 by 48.99% ($P \leq 0.05$) and IL-6 by 22.27% ($P \leq 0.05$); then in patients with "exudative" form these excesses were more significant and amounted to 113.23% ($P \leq 0.05$); 189.13% ($P \leq 0.05$); 221.98% ($P \leq 0.05$) and 122.85% ($P \leq 0.05$) (Table 1).

Effective protection of the body is mainly through the formation of cellular immunity, a Th1-dependent immune response. Activation of Th1-lymphocytes secreting IFN- γ , FNT- α , IL-1 and IL-6 and other pro-inflammatory cytokines is accompanied by an increase in macrophage activity, phagocytosis stimulation, intracellular killing, antigen-presenting function of monocytes, and synthesis of adhesion molecules. As mediators of acute and chronic inflammation, pro-inflammatory cytokines activate fibroblasts, keratinocytes, osteoclasts, granulocytes; increase inflammation, stimulating the synthesis of proinflammatory agents of γ -interferon, tumor necrosis factor, interleukin-6 and –8, causing tissue damage due to an autoimmune reaction [5, 93–98; 7, 25–37; 8, 1–200].

Simultaneously, in all patients, activation of Th 2-type markers of the immune response was observed. Thus, the level of IL-10, a natural antagonist of IFN γ , significantly increased in patients with a "dry" form compared to the values recorded in the control group in the serum by 43.55% ($P \leq 0.05$); and IL-4 by 34.37% ($P \leq 0.05$); in patients with "exudative" form at 30.05% ($P \leq 0.05$) and 48.26% ($P \leq 0.05$), respectively. The corresponding dynamics in the oral one was an increase in the level of IL-10 by 27.76% ($P \leq 0.05$) and 16.05 ($P \leq 0.05$), and IL-4 by 19.00% ($P \leq 0.05$) and 22, 24, and IL-4 at 34.37% ($P \leq 0.05$) (Table 1).

Table 1. – The concentration of cytokines in patients with different clinical course of ECH

The index in the test material (mole)		The level of cytokines (pg/ml)		
		Control n = 10	«Dry» form n = 17	Exudative form. n = 10
1	2	3	4	5
FNT- α	Blood serum	24.52 ± 1.02	36.42 ± 1.51*	52.62 ± 2.03*
	Oral fluid	42.31 ± 0.65	53.61 ± 2.60*	90.22 ± 3.11*
IL-1	Blood serum	6.92 ± 0.34	10.31 ± 0.91*	12.33 ± 0.10*
	Oral fluid	11.22 ± 0.56	15.62 ± 0.74*	32.44 ± 1.58*
IL-6	Blood serum	8.44 ± 0.42	10.32 ± 0.42*	15.65 ± 0.62*
	Oral fluid	12.92 ± 0.64	17.83 ± 0.81*	41.60 ± 1.36*
IFN- γ	Blood serum	18.62 ± 0.71	26.52 ± 1.81*	41.32 ± 2.03*
	Oral fluid	34.83 ± 0.88	44.39 ± 1.72*	77.62 ± 2.65*

1	2	3	4	5
IL-4	Blood serum	13.85 ± 0.69	18.61 ± 0.82*	20.52 ± 0.99*
	Oral fluid	27.52 ± 1.37	32.75 ± 1.50*	33.64 ± 1.38*
IL-10	Blood serum	14.81 ± 0.65	21.26 ± 0.71*	19.26 ± 0.62*
	Oral fluid	26.55 ± 1.06	33.92 ± 1.488	30.81 ± 1.32*
IFN- γ / IL-10	Blood serum	1.26 ± 0.06	1.25 ± 0.06	1.00 ± 0.05
	Oral fluid	1.31 ± 0.06	1.308 ± 0.06	2.50 ± 0.15

Note: * – $P < 0.05$ in relation to the control;

– $P < 0.05$ in relation to the “dry” form.

It can be assumed that the detected anti-inflammatory effect is compensatory and is aimed at preventing the damaging effect of the excess cellular response.

The balance between these two opposing groups of cytokines largely determines the nature of the course of the disease. The relationship between the increase in IL-10 and IL-4 levels and the clinical form of the disease was noted: in patients with a dry form of the disease, the ratio of IFN γ / IL-10 in the serum and oral fluid of patients remained balanced and did not differ significantly from the control group. With the “exudative” form, this indicator increased, which indicated an increase in the priority of Th1 immune response.

Thus, the conducted studies made it possible to reveal a different direction of changes in the cytokine profile in patients with EC, depending on the clinical form of the disease:

– the “dry” form is characterized by synchronous build-up of Th1 and Th2 responses, which leads to the limitation of excessive production of pro-inflammatory cytokines and promotes a relatively successful course of the disease in this category of patients.

– in patients with “exudative” form, the prevalence of the Th1-type of differentiation of the helper response is recorded, which determines the more severe clinical course of the disease

Clarification of pathogenetic mechanisms reveals the role of cytokine regulation in the character of the flow of ECH. This is necessary for the development of preventive diagnostic methods, complex therapy, taking into account the clinical features of the disease and justifying new approaches to treatment and prevention.

References:

1. Isamulaeva A. Z., Spitsyna A. V., Magomedov Sh. Sh., Shatueva S. Z., Isamulaeva A. I. The Importance of Cytokine Regulation in the Pathogenesis of Diseases of the Oral Mouth // Modern Problems of Science and Education.– 2014.– No. 6; URL: <https://www.science education.ru/en/article/view/id=15411>
2. Prokhodnaya V. A., Gayvoronskaya T. V. Cytokine profile of oral fluid in pregnant women with inflammatory periodontal diseases // International Journal of Applied and Fundamental Research.– 2015.– No. 3–4.– P. 655–660.
3. Sabirova A. I. Cytokine status in patients with generalized periodontitis and metabolic syndrome // Vestnik KRSU.– 2016.– Volume 16.– No. 7.– P. 102–105.
4. Ai M. A. case study in treating pediatric chronic cheilitis // Chang Chun Da Xue Xue Bao,– 2011.– 21 (10).– P. 60–61.
5. Aleksandrov A. P., Mirkov I., Zolotarevski L., Ninkov M., Mileusnic D., Kataranovski D., Kataranovski M. Oral warfarin intake affects skin inflammatory cytokine responses in rats // Environ Toxicol Pharmacol.– 2017.– 54.– P. 93–98. doi: 10.1016 / j.etap.2017.06.027. Epub – 2017. Jun 28.
6. Almazrooa S. A., Woo S. B., Mawardi H., Treister N. Characterization and management of exfoliative cheilitis: a single-center experience // Oral Surg. Oral Med. Oral Pathol. Oral Radiol.– 2013.– 116 (6).– e 485–489. 10.1016 / j.oooo.2013.08.016 [PubMed] [Cross Ref]
7. Eichinger K. M., Resetar E., Orend J., Anderson K., Empey K. M. Age predicts cytokine kinetics and innate immune cell activation following intranasal delivery of IFN γ and GM-CSF in a mouse model of RSV infection // Cytokine.– 2017.– 97.– P. 25–37. doi: 10.1016 / j.cyto.2017.05.019. Epub – 2017. May 27.

8. Richard T., Robinson A., Huppler R. The Goldilocks model of immune symbiosis with Mycobacteria and Candida colonizers // Cytokine.– 2017.– Vol. 97.– P. 1–200.

Babamuradova Z. B.,

Shodikulova G. Z.,

Mirzaev O. V.

E-mail: shodikulovagulandom@mail.ru

TREATMENT OF PATIENTS WITH UNDIFFERENTIATED CONNECTIVE TISSUE DYSPLASIA IN MITRAL VALVE PROLAPSE WITH VARYING DEGREES OF MITRAL REGURGITATION

Abstract: The aim of the study is to correct the revealed disorders in patients with undifferentiated connective tissue dysplasia (UCTD) with primary mitral valve prolapse (MVP). 86 patients aged from 15 to 25 (19.5 ± 1.42) years were examined. The study showed that the magnesium preparation, especially in combination with L – arginine, improves the parameters of hemodynamics and heart function in patients with PMK.

Keywords: undifferentiated connective tissue dysplasia, mitral valve primary prolapse, treatment, L – arginine.

The problem of treating various clinical forms of UCTD is extremely complex and requires consideration of clinical manifestations of the pathology. Cases of generalized forms of UCTD that involve various organs and systems into the pathological process require an integrated therapeutic approach with the use of both non-medicamentous and medicamentous methods of treatment. Pathogenetic drug therapy is of a substitutionary nature and it is carried out in several directions. First of all, it is stimulation of collagen formation, correction of glucosaminoglycans synthesis disorders, and a decrease in decomposition of these compounds. Stabilization of mineral metabolism, maintaining a sufficient level of free amino acids in the blood serum, and improving bioenergetic condition of the body should not be forgotten. [1].

It's been proven by many authors that the introduction of magnesium preparations in the course of treatment for patients with cardiovascular pathology contributes to restoration of the disturbed heart rhythm, as well as contributes to a significant decrease in the depth of cusp prolapse in the affected heart valve [2]. With Mg + 2 deficiency, transport-noncoding DNAs are restabilized (the number of dysfunctional RNA molecules increases), which is accompanied by a slowing down of synthesis rate of protein structures of cells with a relative predominance of the apoptosis process [3]. In connection with this, we used a magnesium preparation in the treatment of patients with congenital MVP, which

[5] provided a distinct positive dynamics of clinical and instrumental symptoms of UCTD manifestations. Another preparation used was L-arginine, providing for antihypoxic, membrane stabilizing, cytoprotective, antioxidant action.

The above listed facts stipulated the process of this study, which goal is correction of the revealed disorders in patients with undifferentiated connective tissue dysplasia in primary mitral valve prolapse with various degrees of mitral regurgitation.

Materials and methods. 86 patients aged between 15 and 25 (19.5 ± 1.42) with signs of primary MVP were examined and diagnosed based on the classification by T. I. Kadurina [4]. The diagnosis was later confirmed by EchoCG and ECG studies. Patients with UCTD and with mitral valve prolapse demonstrated significant reduction in serum magnesium and dysfunction of the endothelium, the severity of which depended on the degree of regurgitation. The patients were divided into 2 groups: group 'A', 45 patients with MVP, treated with a magnesium preparation in a daily dose of 3.0 (2 tablets 3 times a day for 10 days, then 1 tablet 3 times a day for 6 months) and group 'B', 41 patients with MVP, who were prescribed a 6-month course of preventive and therapeutic treatment with preparation of magnesium + L-arginine in a daily dose of 4.2 g, administered with 100 ml physiological solution for 7–10 days daily intravenously, with a subsequent 2 months interval. The course

was repeated three times. The efficacy was assessed based on clinical laboratory and instrumental studies.

The conducted studies showed high efficiency of the proposed treatment methods of UCTD with MVP. Thus, with use of magnesium preparation (group A), the frequency of patients' complaints of dyspnea decreased statistically significantly by 2.86 ($P < 0.001$) and 2.44 ($P < 0.001$) times, complaints of air shortage decreased significantly by 10 ($P < 0.001$) and 7.35 ($P < 0.001$) times, respectively to the degree of regurgitation. Despite this, 35 and 40.9% of patients retained complaints of mild dyspnea. Dyspnea of average severity, observed in these patients prior to treatment, turned into a light degree in some patients. Severe and moderate dyspnea, observed in these patients before treatment, remained as a mild degree of air deficiency in 10 and 13.6% of patients. The patients did not complain of headaches. The frequency of ECG disorders detection in patients of this group decreased by 4.5 ($P < 0.001$). As it can be clearly seen from the data presented, prescription of magnesium preparation had a positive effect, contributing to a significant decrease in the clinical manifestations of mitral valve prolapse.

Inclusion of L-arginine into the treatment scheme in addition to magnesium (group B) contributed to even more increase in the effectiveness of treatment. Thus, the frequency of dyspnea complaints decreased by 3 ($P < 0.001$) and 2.87 ($P < 0.001$) times, relative to pre-treatment values; by 1.05 and 1.18 ($P < 0.05$) times in comparison with the group of patients receiving only the magnesium preparation, respectively to the degree of regurgitation. At the same time, the average degree of dyspnea was not detected, but 33.3 and 34.8% of patients complained of mild dyspnoea. In this group, after long-term treatment, patients did not complain about air deficiency, whereas in Group A these complaints remained in 10 and 15.6% of patients. Just like in Group A, patients in Group B did not complain of headaches after treatment. The changes in ECG, previously observed in patients with UCTD, were not detected after treatment with both preparations, whereas in the group of patients, which received only magnesium preparation, these changes remained in 10 and 18.2% of those treated.

The data obtained indicate high efficiency of the combined use of magnesium and L-arginine for treatment of UCTD with MVP of varying severity. In our

opinion, this is due to a significant improvement in the synthesis of collagen and elastin in fibroblasts under the influence of magnesium ions.

It should be noted that certain changes in the parameters of Doppler echography were noted in patients with UCTD and the presence of MVP, the severity of which increased depending on the degree of regurgitation. Pharmacotherapy of MVP in patients using magnesium preparation showed positive dynamics within 3 months. Thus, patients of group A showed an improvement in the basic indicators characterizing the rhythm and contractile heart activity. This was manifested by a decrease in the parameters of EDD, ESD, systolic and diastolic blood pressure, the number of cardiac contractions on the background of an increase in the parameters of the ejection fraction, cardiac systolic output, MBV. However, these changes were statistically insignificant, especially in patients with second degree of regurgitation.

More pronounced changes in echogeometry of the heart were detected with a longer application. After a 6-month course of treatment with the above medication, EchoCG studies showed that EDD and ESD decreased by 10% ($P > 0.05$) and 16.8% ($P < 0.01$) with 1-st degree of regurgitation, by 10.3% ($P < 0.05$), and 16.5% ($P < 0.01$) with the 2nd degree of regurgitation. The values of cardiac systolic output also significantly decreased by 11.9 ($P < 0.05$) and 9.8% with respect to the initial parameters. The thickness of the posterior wall of the left ventricle tended to decrease, while the values of the intermembrane septum changed significantly: a decrease of 14 ($P < 0.05$) and 15% ($P < 0.05$), respectively to MVP regurgitation.

Low values of ejection fraction increased by 11.6 and 16.9% ($P < 0.05$) relative to the initial parameters, respectively. In addition, there was observed a veracious decrease in heart rate, while the values of SBP and DBP only had a tendency to increase.

A more pronounced clinical efficacy of the 'magnesium' preparation in UCTD patients with MVP was noted after 6 months of treatment. It can be assumed that the lack of sufficiently complete clinical efficacy in patients with UCTD and MVP was associated with the different action of the magnesium preparation in patients with varying degrees of valve regurgitation. Magnesium preparation had a more pronounced pharmacological effect in patients with more pronounced disorders.

Consequently, our observations show that only with prolonged use. Clinical efficacy is increased depending on individually selected doses of the preparation; the dose of 'Magnesium Preparation' 1 tablet 3 times a day, i.e. 3g / day is enough to improve the myocardial contractility in 6 months, while the basic mechanism of MVP compensation does not suffer.

The patients of B group received L-arginine together with a preparation of magnesium. In this group of patients, we observed changes that are more pronounced in cardiac hemodynamics. Pharmacotherapy of MVP in patients with the use of the magnesium preparation + L-arginine for 3 months showed a positive trend. Thus, in patients of group A, there was a decrease in the studied parameters of cardiac hemodynamics, systolic and diastolic blood pressure, and the number of heartbeats against the background of an increase in the parameters of cardiac systolic output. However, these changes were statistically insignificant, especially in patients with a second degree of regurgitation.

More pronounced changes in the echogeometry of the heart were detected with longer application. After a 6-month course of treatment with this preparation, EchoCG studies showed that EDD and ESD decreased by 20% ($P > 0.05$) and 29.1% ($P < 0.01$) with the first degree of regurgitation, by 21.4% ($P < 0.05$), and 32.5% ($P < 0.01$) with the second degree of regurgitation. The values of cardiac systolic output also significantly decreased by 19 and 17.6% with respect to the initial parameters. The thickness of posterior wall of the left ventricle decreased by 9.2 and 19.6% ($P < 0.05$), while the values of the intermembrane septum changed significantly by 21.9 ($P < 0.05$) and 18.5% ($P < 0.05$), respectively to MVP regurgitation. Low values of ejection fraction increased by 10.3 and 20.6% ($P < 0.05$) relative to the initial parameters, respectively. Along with this, there was observed a veracious decrease in heart rate, while the values of SBP and DBP only had a tendency to increase. A more pronounced clinical efficacy of the proposed therapy in UCTD patients with MVP was noted after 6 months of treatment. At the same time, a more complete clinical efficacy, observed in patients with UCTD and MVP, was associated with different effects of both preparations in patients with varying degrees of regurgitation.

The performance analysis of flow-dependent vasodilatation in the compared groups of individuals with MVP and varying degrees of blood flow regurgitation during the 6-month prophylactic treatment showed that

the magnesium preparation had no significant effect on the diameter of brachial artery before and after the test in patients with 1st degree MVP. The test revealed only a tendency to an increase in brachial artery diameter. In this regard, the increase in the diameter after the test in treated patients with 1-st degree MVP was statistically significant: by 1.53 ($P < 0.01$) with respect to the values before treatment, and got close to that of practically healthy individuals. However, the values of MSPPA, which had only a tendency to increase before the treatment, statistically significantly increased after the test by 1.53 ($P < 0.01$) times relative to the initial values, which led to an increase in the resistance index by 1.5 ($P < 0.01$) times, with respect to values before treatment.

At the same time, in patients with II degree MVP, who received the magnesium preparation for 6 months, the values of DBA before and after the test did not change significantly, and the gain statistically significantly increased by 1.27 ($P < 0.05$) times. In this case, both the values of MSPPA before and after the test and the resistance index did not change with respect to the initial values. All the studied indicators of this subgroup of patients were statistically insignificantly different from the values of practically healthy individuals.

In patients of group B, treated with magnesium preparation + L-arginine, positive dynamics was observed in patients with MVP 1st degree of regurgitation. The values of DBA before and after the test tended to increase, the growth statistically significantly increased by 1.62 ($P < 0.001$) times relative to values before treatment. However, this figure remained significantly below the normative values. The **MSPPA** index before the treatment had only a tendency to increase, while its values after the test significantly increased by 1.4 ($P < 0.05$) times, which led to an increase in the resistance index by 1.39 ($P < 0.05$) times compared to before treatment. All the studied parameters were statistically significantly different from the values of practically healthy individuals.

In patients with the 2nd degree of mitral valve regurgitation, who received magnesium + L-arginine, the values of flow-dependent dilatation did not differ significantly from the initial parameters and were significantly different from those of practically healthy individuals. As can be seen from the data presented, the use of the magnesium preparation alone and in combination with L-arginine had a positive effect on vascular wall parameters in

patients with the first degree of regurgitation, whereas in patients with the 2nd degree of regurgitation the effectiveness of treatment was weak.

Our observations show that magnesium preparation in combination with L-arginine has a more pronounced pharmacological effect with prolonged use. Apparently, this is due to potentiation of magnesium preparation under the influence of L-arginine. However, it should be noted that L-arginine itself corrects the observed endothelial dysfunction.

Thus, the results of the studies showed that magnesium preparation, especially in combination with L-arginine, improves the parameters of hemodynamics and heart function in patients with MVP, which pathogenetically substantiates its prescription as adequate treatment for prophylactics and preventive therapy for patients with UCTD and MVP. However, their effectiveness in terms of correcting endothelium-dependent dilatation was noted only in patients with the first degree of regurgitation.

References:

1. Seelig M. S. Metabolic Sindrom – X. A complex of common diseases – diabetes, hypertension, heart disease, dyslipidemia and obesity – marked by insulin resistance and low magnesium/high calcium // *Mineral Res. Intern. Tech. Prod. Infor.* – 2003. – P. 1–11.
2. Белозеров Ю. М., Османов И. М., Магамедова Ш. М. Новый взгляд на проблему пролапса митрального клапана у детей и подростков // *Кардиология.* – 2010. – № 1. – С. 15–23.
3. Басаргина Е. Н. Синдром дисплазии соединительной ткани сердца у детей // *Вопр. соврем. педиатрии.* – 2007. – Т. 6 (6). – С. 50–53.
4. Белозеров Ю. М., Османов И. М., Магамедова Ш. М. Проблема пролапса митрального клапана у детей и подростков // *Российский вестник перинатологии и педиатрии.* – 2009. – № 4. – С. 15–23.
5. Андреева Е. О., Корякитина Л. Б., Курильская Т. Е. и др. Дисфункция эндотелия у больных стенокардией напряжения II и III функционального класса // *Клин.лаб.диagn.* – 2008. – № 10. – С. 15–17.

*Bakhritdinova Fazilat Arifovna,
doctor, of medicine, professor,
Tashkent medical academy, department of ophthalmology
E-mail: bakhritdinova@mail.ru*

*Bilalov Bakhodir Erkinovich,
manager, of the department of ophthalmology
Tashkent medical academy, department of ophthalmology
E-mail: tma-glaz@mail.ru*

PREVENTION OF EXCESSIVE SCARRING IN TERMINAL GLAUCOMA

Abstract: The results of present study of surgical treatment of terminal glaucoma by prevention of excessive scarring using the method of auto drainage of filtration zone are presented. Remote results of clinical studies have shown that the patients of the main group, the operation resulted in a significant decrease of intraocular pressure (IOP), after the subsequent observation period IOP gradually increased within normal variation (20–23 mm Hg), and it stabilized by 6 months after treatment and averaged 21.1 ± 1.3 mm Hg.

The decrease of the height of filtration cushion (FC) was not observed in 6 months period in the patients of the main group. The proposed operation of deep sclerectomy with auto drainage of the filtration zone, which contributed to a significant improvement in tonometric parameters that made it possible to increase the effectiveness of terminal glaucoma treatment.

Keywords: terminal glaucoma, intraocular pressure, ultrasonic biomicroscopy, filtration cushion, scleral flap, intrascleral cavity.

The topicality of the study. Glaucoma is one of the most common and severe eye diseases and occupies one of the main places in the structure of blindness and blurry vision. Despite the certain success achieved in the diagnosis and treatment of early stages of the disease, part of the patients who have been complaining are already consulting in the terminal stage of the disease [9, 10, 13].

The problem of treating terminal glaucoma in the world ophthalmology is still in the leading position. Despite the success in studying the normal physiology of intraocular pressure, in the medical treatment of glaucoma due to the appearance of new types of medicine, as well as the constantly improving types of surgical and laser interventions [1, 2, 3, 4, 5, 6, 7, 8, 12], the terminal glaucoma is still one of the main causes of irreversible blindness.

Drug therapy in the terminal glaucoma is often ineffective due to the expressed dystrophic changes in the drainage system of the eye and ciliary body, iris rubeosis. Usually, such patients are treated conservatively before the onset of pain syndrome, and since drug treat-

ment is ineffective in its development, and only treated surgically [2, 3, 4, 5].

At present the preservation of the organ is the main direction in the field of ophthalmology. In our country and abroad the most common are two areas in the organ-preserving surgical treatment of terminal glaucoma. First, these are various modifications of fistulizing operations [3, 7, 11]. Secondly, the thermal and laser operations [2, 4, 6, 8] effect on the ciliary body in order to lower the secretion of watery moisture.

The unpredictability of the hypotensive effect and a number of serious complications, both in the early and late postoperative period after cyclodestructive interventions, they limit their broad application in the treatment of terminal glaucoma [6, 12].

Another approach that has attracted ophthalmologists for a long time was an attempt to create drainage that provides a directed outflow of watery moisture under the conjunctivitis in order to reduce the ophthalmotonus [1, 5, 7, 13, 14]. According to the literature, the

percentage of IOP normalization after drainage surgical interventions varies from 20 to 75%. Complication of drainage surgery includes hypotension leading to a ciliochoroidal detachment, suprachoroidal hemorrhage, hypotonic maculopathy, corneal decompensation, as well as limiting the mobility of the eyeball and diplopia, endothelial-epithelial dystrophy [1, 3, 7].

Thus, in order to create an outflow from the anterior chamber, it is important not to have moves in the drainage, but to form slit-like spaces around it that are as close as possible to the physiological pathways of the outflow of the anterior chamber moisture.

The aim of study. To evaluate the effectiveness of surgical treatment of terminal glaucoma by preventing excessive scarring by autodraination method of the filtration zone.

Materials and methods of study. 60 patients were observed (60 eyes) with terminal glaucoma with high IOP, the distribution was as follows: 37 (61.7%) men, 23 (38.3%) women. The age of patients ranged from 40 to 70 years. The mean age of the patients was 55.7 ± 3.4 years.

Based on the anamnesis of patients, the following diseases were the causes of terminal glaucoma: primary glaucoma in 35 (58.3%) patients, of which closed-angle glaucoma in 21 (60%) and open-angle glaucoma in 14 (40%) patients, and secondary glaucoma of different

etiology in 25 (41.7%) patients. The causes of the secondary glaucoma were: thrombosis of the central vein of the retina (CVR) and its branches in 12 (48%), diabetes mellitus in 9 (36%) patients, who had uveitis in 2 (8%), and eye injury in 2 (8%). The first control group consisted of patients who underwent deep sclerectomy with preliminary posterior trepanation of the sclera – 30 patients (30 eyes). The second main group consisted of 30 (30 eyes) patients who underwent antiglaucomatous operation with autodraination of the filtration zone by V. P. Yerichev [7] in our modification (RUz., rationalization proposal No. 651 of 11.09.2013, «Modified surgical method for the treatment of refractory glaucoma». Bakhritdinova F. A., Bilalov E. N., Bilalov, B.E.).

The effectiveness of the treatment was determined by the data of biomicroscopy, the assessment of the condition of filtration cushion, pain relief, tonometry, tonography, ultrasound biometry and ultrasound biomicroscopy. The observation period made up 6 months.

Results and discussion. In all patients before the surgery, ophthalmotonus compensation for anti-hypertensive drugs was absent and averaged 47.1 ± 5.2 mm Hg. The visual functions in patients with terminal glaucoma of both groups were practically lost, in 45 (75%) cases the visual acuity was equal to zero; in 15 (25%) there was a light sense with an incorrect projection of the light.

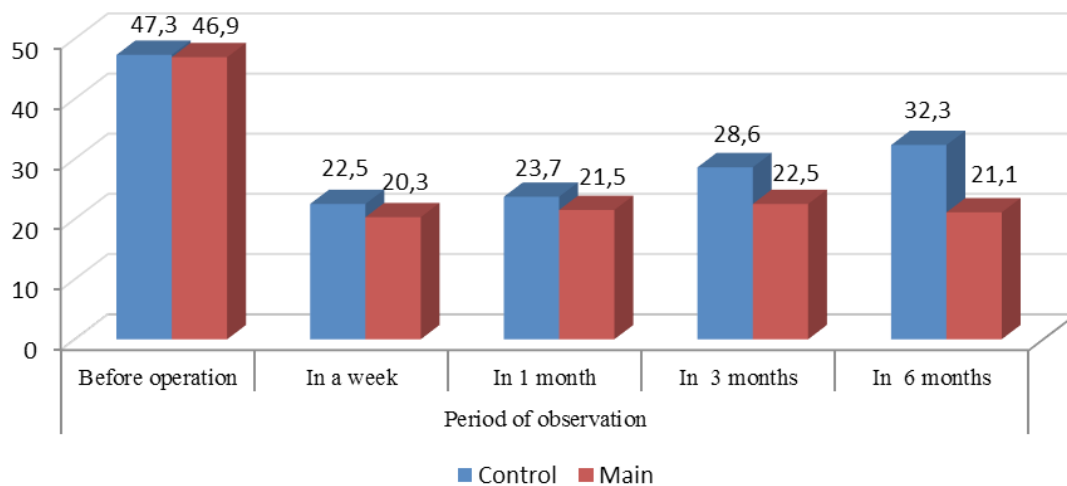

Figure 1. Dynamics of intraocular pressure in different terms after the treatment ($M \pm m$)

Note: * – differences in comparison with initial values are statistically significant; ($P < 0.05$);

– differences in comparison with the values of control group after the treatment are statistically significant ($P < 0.05$);

Significant positive dynamics was noted in the state of iris and the angle of the anterior chamber of an eye. After the surgery in most patients, the newly formed vessels

of the iris and the angle of the anterior chamber under the gonioscopic picture became noticeably disappeared. 3–6 months after the operation the frequency of occurrence

of iris rubeosis was noted only in 1 (5%) patient in the main group. In the control group the frequency of occurrence of iris rubeosis was noted in 8 (40%) patients.

The hypotensive effect of surgical interventions in the early postoperative period (5–7 days after the surgery) and the long-term period (from 1 month to 6 months) is presented in pic. 1.

In early postoperative period in the main group the IOP level corresponded to a moderately expressed hypotension – 16–18 mm Hg, and in the control group – 20–22 mm Hg.

A week after the operation, IOP decreased in 2, 3 times in patients in the main group relatively to the operating indices and averaged 20.3 ± 1.8 mm Hg, in patients in the control group this index decreased 1,8 times.

Long-term results of clinical studies showed that in patients in the main group the operation resulted in significant decrease of IOP, which in subsequent observation period gradually increased within the normal variation (20–23 mm Hg), it stabilized to 6 months after the treatment and averaged 21.1 ± 1.3 mm Hg, where as the mean IOP was 32.3 ± 1.5 in the control group.

In the first day after the operation, a filter cushion (FC) was visualized in patients of all clinical groups with biomicroscopy without signs of inflammation. The filter cushion was significantly marked in the patients in the main group and it was less marked and flatter in the control group.

According to the UBM data, in the early term after the operation (1 month later), in patients in the main group had a well- marked FC, the height of which varied in the range of 1.32 ± 0.04 mm. Its volume on average made up 55.3 ± 2.44 mm³ and the acoustic density of this structure was in the range of $40 \pm 5\%$. The sclerotic flap (SF) with an average thickness of 0.38 ± 0.002 mm was clearly visualized. The acoustic density of SF on average made up $65 \pm 10\%$. The height and volume of the intrasclerotic cavity (ISC) ranged within 0.65 ± 0.03 mm and 4.81 ± 0.35 mm³, respectively. The acoustic density was within $30 \pm 5\%$. Already in the early stages hypoechogenic tunnels were marked in all eyes, resulting in from under the SL and connecting the ISP with OP.

1 month after the operation the changes were detected in all levels of the drainage system in the patients of the control group. FC was less marked, and its height on average made up 0.41 ± 0.03 mm and volume – 6.26 ± 1 mm³.

The acoustic density of SF was in the range $63 \pm 3\%$ and was higher than in patients in the main group.

After 3 months FC was more marked in the main group (1.23 ± 0.03 mm) than in the control group (0.38 ± 0.02 mm) and differed in the decrease of the volume up to 36.45 ± 0.02 mm in the main group and up to 8.8 ± 0.4 mm in the control group.

Within 6 months a decrease in the height of the FC was not observed in the patients of the main group, it seems that it is apparently due to autodraination of the filtration zone.

Typical for a 6-month follow-up period after treatment of patients in the control group, a progressive decrease in the parameters of the drainage system examined for UBM was noted against the background of a progressive increase in the acoustic density of the structures.

During postoperative period the absence of FC was detected much more often in 51% of cases in the control group and the height averaged 0.35 ± 0.01 mm, volume – 8.4 ± 0.3 mm³.

Although the SF thickness decreased slightly in the patients in the main group, compared with the previous terms and it made up 0.28 ± 0.002 mm, but the acoustic density of the structure remained in the range of $65 \pm 5\%$. In patients of the control group the thickness and acoustic density of SF continued to increase and made up 0.38 ± 0.01 mm ($90 \pm 5\%$). Occurring visualized changes undoubtedly testify to the gradual development of sclero-conjunctival fusion, as well as the fibrosis of adjacent integumentary tissues.

The investigated average values of height and volume of intrasclerotic cavity (ISC) in patients in the main group were 0.40 ± 0.01 mm respectively, 1.65 ± 0.24 mm³. The acoustic density of the structure remained low, to $35 \pm 5\%$. A hypoechoic slit connecting the ISP with FC and reflecting the intensity of outflow of intraocular moisture from under the conjunctiva was present in 80% of cases. In the control group, the dimensions of the ISC (height 0.28 ± 0.02 mm, volume 1.23 ± 0.08 mm³) were significantly reduced, in comparison with the previous studies.

Conclusion. 1. The proposed operation of deep sclerectomy with autodraination of the filtration zone, contributing to a significant improvement in tonometric parameters, enabled to improve the effectiveness of terminal glaucoma treatment. Compensation of the ophthalmotonus was noted in 83.3% of cases.

2. In terms of UBM indices in the long-term period, after operation with autodraination of the filtration zone, the parameters of FC and ISC with a reduced acoustic density (56.6%) were retained, satisfactory visualization of tunnels (75%) was noted, which confirms the func-

tioning of drainage system structures. In the traditional antiglaucomatous operation of deep sclerectomy with iridectomy, these parameters were respectively, 67.5% and 50.5%, which indicates more marked violations of the drainage system of the eye.

References:

1. Анисимова С. Ю., Анисимов С. И., Рогачева И. В. Хирургическое лечение рефрактерной глаукомы с использованием нового, стойкого к биодеструкции коллагенового дренажа // Глаукома. – 2006. – № 2. – С. 51–56.
2. Бачалдин И. Л., Егоров В. В., Марченко А. Н., Сорокин Е. Л. Трансклеральная диодлазерная циклокоагуляция в лечении терминальной болящей глаукомы // РМЖ – 2007. – Т. 8. – № 4.
3. Бикбов М. М., Суркова В. К., Хуснитдинов И. И., Чайка О. В., Оренбуркина О. И., Джамантаева Ш. Д. Результаты применения дренажа Ahmed при рефрактерной глаукоме // РМЖ. «Клиническая офтальмология». – Москва, – 2013. – № 3. – С. 98–101.
4. Бойко Э. В., Куликов А. Н., Скворцов В. Ю. «Лазерная циклодеструкция: термотерапия или коагуляция» // Сборник трудов 12-й всероссийской школы офтальмолога. – 2013. – Москва. – С. 45–55.
5. Вашкевич Г. В., Имшенецкая Т. А., Ситник Г. В. Отдаленные результаты синусотрабекулоэктомии с интраклеральной и эписклеральной амниопластикой при глаукоме с различной степенью риска послеоперационного рубцевания // РМЖ. «Клиническая офтальмология». – Москва, – 2011. – № 4. – С. 142–144.
6. Гаврилова Т. В., Мухамадаева С. Н. Эффективность применения трансклеральной диодной циклофотокоагуляции в лечении больных с терминальной болящей глаукомой. // Сборник статей 12-й всероссийской школы офтальмолога. – Москва. – 2012. – С. 59–61.
7. Еричев В. П., Бессмертный А. М., Робустова О. В. Хирургическая профилактика склеро-склеральных сращений у больных рефрактерной глаукомой // Актуальные проблемы офтальмологии: Сб. науч. тр. – М., – 2003. – С. 214–215.
8. Либман Е. С., Калеева Э. В., Рязанов Д. П. Комплексная характеристика инвалидности вследствие офтальмопатологии в Российской Федерации. // Федоровские чтения – 2011: 9-я Всероссийская научно-практическая конференция с международным участием. Сб. тезисов. – М., – 2011. – С. 57–82.
9. Мазунин И. Ю., Краева А. А., Кравецкая Е. И. Динамическая микроимпульсная диодлазерная трансклеральная циклокоагуляция (ДМИДТЦК) в лечении далекозашедших стадий глаукомы // Глаукома: теории, тенденции, технологии. НРТ Клуб Россия – 2009: VII международная конференция: Материалы. – М., – 2008. – С. 357–360.
10. Нероев В. В. Основные пути развития офтальмологической службы Российской Федерации // Тез. докл. IX съезда офтальмологов России. – М., – 2010. – С. 52–55.
11. Connor M., Knape R., Oltmanns M. Et al. Trainee glaucoma surgery: experience with trabeculectomy and glaucoma drainage devices // Ophthalmic Surg Lasers Imaging. – 2010. – 41(5). – P. 523–31.
12. Neuburger M., Bringer D., Jordan J. F. Endocyclophotocoagulation for the treatment of glaucoma // Ophthalmologie. – 2010. – Jan; 107(1). – P. 68–74.
13. Patel S., Pasquale L. R. Glaucoma drainage devices: a review of the past, present, and future // Semin Ophthalmol. – 2010. – 25(5–6). – P. 265–70.
14. Tzamalidis A., Pham D. T., Wirbelauer C. Diode laser cyclophotocoagulation versus cyclocryotherapy in the treatment of refractory glaucoma // Eur J Ophthalmol. – 2011. Sep–Oct. – 21(5). – P. 589–596.

*Bekjanova Olga Esenovna,
Ph D., ScD, Tashkent State Dental Institute, Uzbekistan
the Faculty of Therapeutic stomatology
E-mail: bekjanovaolga@mail.ru*

*Rizaev Elyor Alimjonovich,
Department of stomatology, pediatric stomatology and orthodontics
Tashkent Institute of Postgraduate Medical Education, Uzbekistan
E-mail: elyorboyrizaev@gmail.com*

PREVALENCE AND INTENSITY OF TEETH CARIES AT THE CHILDREN SICK WITH THE HERPETIC STOMATITIS

Abstract: Studying from a condition of hygiene of an oral cavity showed that children with HS in an age group have 6 months – 3 years the size of Fedorov-Volodkina index makes $1,67 \pm 0,07$ that corresponds to “satisfactory” hygiene of an oral cavity, at the same time at children without HS the condition of hygiene of an oral cavity was estimated as “good” – 1.25 ± 0.05 ($P \leq 0.05$). Children of an age group of 3 years 1 months – 6 years with HS hygiene of an oral cavity was “unsatisfactory” – the size of OHI-S index made 2.53 ± 0.09 , at children without HS hygiene of an oral cavity was estimated as “satisfactory” 1.62 ± 0.07 ($P \leq 0.05$).

Keywords: herpetic stomatitis, teeth caries, CSR(z) index, children with a herpetic stomatitis, Fedorov-Volodkina’s index, RMA index in Parma, OHI-S – an index.

Updating of the preventive direction in medicine aggravated a problem of relationships of cause and effect between existence of the herpetic stomatitis (HS) and intensity of the basic stomatologic diseases [1, 9–12; 2, 56–58; 5, 19–20; 6, 200–210; 8, 90–91; 9, 179–180].

Therefore, the studying of a stomatologic case rate of children with a herpetic stomatitis which is based on the comprehensive analysis of a condition of stomatologic health is an urgent medical-social task which solution will allow to optimize impact on a chain of development of pathological process taking into account a condition of the stomatologic status and to gain the maximum therapeutic and preventive effect [2, 758–760; 3, 256–260; 7, 33–34; 10, 56–58].

However, so far comprehensive examination of children of patients with a herpetic stomatitis, according to demands of WHO, wasn’t carried out at the period of living in the territory of Tashkent.

So far it isn’t developed a universal algorithm of holding preventive actions taking into account an individual clinical situation in an oral cavity.

All above testifies to relevance of a problem of this subject and carrying out the real research.

Aim of the research: the comparative analysis of prevalence and intensity of teeth caries at children sick with a herpetic stomatitis.

Materials and methods. For the purpose of standardization of diagnostics of a case rate of teeth caries carious lesions during the research were revealed with use of a visual method.

Prevalence and intensity of stomatologic diseases studied at 156 children with a HS, as control indicators of a stomatologic case rate at 153 children of comparable gender and age never being ill a HS (Table 1) are studied. The compared groups were randomized also according to the social status, conditions of accommodation and a delivery for an exception of their influence on risk of developing of herpesvirus infections.

Prevalence of teeth caries was counted as the attitude of number of the persons having at least one of signs of implication of teeth caries (the carious, sealed-up or extracted teeth), towards total number surveyed, expressed as a percentage.

For assessment intensity of caries of temporary teeth was used by indexes:

CSR (z) index – the sum of the teeth affected with not treated caries (“c” component), which are sealed up (“s” component) and removed (“r” component) at one

examined child. When determining number of the extracted teeth, only those which are removed prematurely, before their physiological change are considered.

Table 1. – Gender – age of children of compared groups

HS, Basic group	Age groups								Total		Total number of children
	6 mon. – 3 years		3 years 1 mon. – 6 years		6 years 1 mon. – 10 years		10 years 1 mon. – 15 years				
	B	G	B	G	B	G	B	G	B	G	
Mild degree	13	9	3	5	3	4	3	3	22	21	43
Medium severity	30	37	6	7	3	3	2	2	41	49	90
Severe degree	10	11	–	1	–	1	–	–	12	11	23
Total	53	57	9	13	6	8	5	5	75	81	156
Comparison group, control	52	56	10	11	5	9	5	5	72	81	154

For second teeth counted an index of the CSR (z) – the sum carious (component “C”), the teeth which are sealed up (component “S”) and extracted (component “R”) at one surveyed.

The hygienic condition of an oral cavity at children up to 3 years was estimated by means of Fedorov-Volodkina’s index. For assessment of a hygienic condition of an oral cavity at children after 3 years used the simplified index of hygiene of an oral cavity – OHI-S – an index. For detection of severity of an ulitis the RMA index in Parma modification was used.

For definition of an indicator of prevalence of caries the number of persons at whom taped symptoms of caries was divided into total number surveyed in this group and expressed as a percentage.

Data recorded in specially developed card of stomatologic inspection where fixed date of inspection, passport data, a floor surveyed, date of birth and age, the place of study, the place of residence, a condition of firm tissues of teeth, tissues of a parodont, a hygienic condition of an oral cavity, existence of dentoalveolar anomalies.

Prevalence of stomatologic diseases was estimated at% of total number of patients in groups. Intensity of caries was counted by standard methods of variation statistics with determination of average arithmetic size (M), an error of average arithmetic (m) for each group. Assessment of reliability of differences (r) between groups was defined by Student’s criterion (t).

Results and discussions As a result of the conducted researches high prevalence and intensity of diseases of

firm tissues of teeth at the children sick with HS (Tables 2 and 3) is established.

Surveys of an oral cavity showed that carious teeth occurred at children with HS and without HS. The tendency to augmentation of prevalence of caries of teeth in more senior age groups is noted. However children with HS had a prevalence of caries of teeth above groups of control.

So, prevalence of caries of teeth among children with a herpetic stomatitis in age – was peer 3 years to $64.55 \pm 4.55\%$ against prevalence of caries at children without HS an age group of 6 months – $35.19 \pm 4.60\%$ ($P < 0.05$); the corresponding ratios in an age group 3 years 1 months – 6 years made $91.30 \pm 5.88\%$ against $47.62 \pm 10.90\%$ ($P \leq 0.05$); children in age groups have 6 years 1 months – 10 years and 10 years 1 months – 15 years in the presence of HS 100,0% prevalence of caries of teeth was registered; the corresponding prevalence of caries in groups of control made – $71.43 \pm 12.07\%$ and $80.00 \pm 12.65\%$ (Table 2).

Average intensity of caries – the CS(z) index at children with HS in an age group of 6 months – was peer 3 years 1.82 ± 0.07 against 1.23 ± 0.05 ($P < 0.05$) group of control. With augmentation of age of surveyed increase of intensity of a lesion by caries both temporary – the CS (z) index, and second teeth – the CS(z) index \pm CSR (z) is established, at the same time in all examined groups children with HS had higher intensity of a carious lesion. So in an age group 3 years 1 months – 6 years $K\pi$ (3) \pm the KPU (z) made intensity of an index at children

with HS – 4.11 ± 0.17 against 3.23 ± 0.15 ($P \leq 0.05$); 10 years 1 months – 15 years – 6.51 ± 0.24 against in an age group of 6 years 1 months – 7.16 ± 0.30 against 3.98 ± 0.11 ($P \leq 0.05$) (Table 2). 5.68 ± 0.21 ($P \leq 0.05$) and in the senior age group of

Table 2. – Comparative data of prevalence and intensity of caries in the compared groups

Indicators	Age groups							
	6 mon. – 3.0 years		3 years 1 mon. – 6 years		6 years 1 mon. – 10 years		10 years 1 mon. – 15 years	
	basic with HS. n = 10	control without HP. n = 8	basic with HS. n = 23	control without HP. n = 21	basic with HS. n = 14	control without HP. n = 14	basic with HS. n = 10	control without HP. n = 10
<<c>>	1.62 ± 0.07	$0.92 \pm 0.03^*$	2.71 ± 0.11	$1.82 \pm 0.07^*$	3.62 ± 0.14	2.12 ± 0.08	–	–
<<s>>	0.22 ± 0.01	$0.31 \pm 0.01^*$	0.62 ± 0.02	$1.23 \pm 0.05^*$	1.14 ± 0.09	$1.62 \pm 0.05^*$	–	–
<<r>>	–	–	–	–	–	–	–	–
csr(z)	1.84 ± 0.07	$1.23 \pm 0.05^*$	–	–	–	–	–	–
<<C>>	–	–	0.63 ± 0.02	$0.11 \pm 0.005^*$	1.63 ± 0.04	$0.62 \pm 0.03^*$	3.92 ± 0.11	$1.32 \pm 0.06^*$
<<S>>	–	–	0.15 ± 0.006	$0.07 \pm 0.003^*$	0.52 ± 0.02	$1.2 \pm 0.05^*$	1.14 ± 0.05	$1.71 \pm 0.07^*$
<<R>>	–	–	–	–	0.25 ± 0.01	$10.11 \pm 0.05^*$	1.45 ± 0.04	$0.95 \pm 0.02^*$
cs(z) – CSR(z)	–	–	4.11 ± 0.17	$3.23 \pm 0.15^*$	7.16 ± 0.30	$5.68 \pm 0.21^*$	6.51 ± 0.24	$3.98 \pm 0.14^*$
Prevalence of TC (%)	73 64.55 ± 4.55	38* 35.19 ± 4.60	21 91.30 ± 5.88	10* 47.62 ± 10.90	10 100	10 71.43 ± 12.07	10 100	8 80.0 ± 12.65

Note: in numerator – number of children; in denominator – in% from number of children in group;

* – $P < 0.05$ in relation to basic group.

Studying of structure of caries showed that children of the youngest age with HS there was also authentically above an intensity of caries (to component) the size of which equaled 1.62 ± 0.07 affected teeth against 0.92 ± 0.03 ($P \leq 0.05$) carious tooth in control; in an age group 3 years 1 months – 6 years a ratio of quantity carious milk teeth (“c” component) and permanent carious teeth (“K”

component) made relatively 2.71 ± 0.11 against 1.82 ± 0.07 ($P \leq 0,05$) and 0.63 ± 0.02 against 0.11 ± 0.005 ($P \leq 0,05$); in older groups 6 years 1 month – 10 years relatively 3.62 ± 0.14 against 2.12 ± 0.08 ($P \leq 0,05$) and in senior age group of 10 years 1 month – 15 years intensity of C element at children with HS made 3.92 ± 0.11 against 1.32 ± 0.06 ($P \leq 0,05$) (Table 2).

Table 3. – Hygiene of children oral cavity at junior age groups

Hygiene indexes	Age group			
	6 mon. – 3 years		3 years 1 mon. – 6 years	
	basic with HS, n = 110	control without HS, n = 110	basic with HS, n = 23	control without HS, n = 21
Fedorova-Volodkina index	1.67 ± 0.07	$1.25 \pm 0.05^*$	–	–
OHI-S – index	–	–	2.53 ± 0.09	$1.62 \pm 0.07^*$

Note: * – $P < 0.05$ in relation to basic group.

It is necessary to notice that children with HS had less sealed-up teeth, the corresponding ratios made on the p component in an age group of 6 years – 3 years – 0.22 ± 0.01 sealed-up teeth against 0.31 ± 0.01 ($P \leq 0.05$) teeth

with seals in control; in an age group 3 years 6 months on the p component – 0.62 ± 0.02 against 1.23 ± 0.05 ($P \leq 0.05$) and on a component “P” – 0.15 ± 0.006 against 0.07 ± 0.003 ($P \leq 0.05$) teeth with seals in con-

trol; the corresponding ratios in an age group of 6 years 1 months – made 10 years 1.14 ± 0.09 against 1.62 ± 0.05 ($P \leq 0,05$) and 0.52 ± 0.02 against 1.21 ± 0.05 ($P \leq 0.05$); the ratio of quantity of seals – made 15 years (component “S”) in the senior age group of 10 years 1 months 1.14 ± 0.05 against 1.71 ± 0.05 ($P \leq 0.05$). It is necessary to notice that in the senior age group intensity of a component “R” – the extracted teeth was also higher at children with HS – 1.45 ± 0.05 against 0.95 ± 0.04 ($P \leq 0.05$) (Table 2).

Studying from a condition of hygiene of an oral cavity showed that children with HS in an age group have 6 months – 3 years the size of Fedorov-Volodkina index makes 1.67 ± 0.07 that corresponds to “satisfactory” hygiene of an oral cavity, at the same time at children without HS the condition of hygiene of an oral cavity was estimated as “good” – 1.25 ± 0.05 ($P \leq 0.05$).

Children of an age group have 3 years 1 months – 6 years with HS hygiene of an oral cavity was “unsatisfactory” – the size OHI-S of an index made 2.53 ± 0.09 . at

children without HS hygiene of an oral cavity was estimated on “well” 1.62 ± 0.07 ($P \leq 0.05$) (Table 3).

Conclusions. Comprehensive comparative stomatologic examination revealed that at children with herpetic lesions of a mucosa of an oral cavity and prevalence and intensity of teeth caries and low level of hygiene of an oral cavity is observed higher ($P \leq 0.05$), in comparison with children without HS. Thus, stomatologic pathology is the pathogenetic mechanism initiating herpetic lesions of a mucosa of an oral cavity.

For an exception of a local stomatologic component complex treatment of herpetic lesions of a mucosa of an oral cavity has to include carrying out professional and rational hygiene of an oral cavity, training of parents and children in hygiene of an oral cavity, selection of personal hygiene means, treatment of caries and its complications.

To the patient who had HS advice and long-term recommendations on care of an oral cavity and well-timed treatment of caries of teeth for the purpose of prophylaxis of a recurrence of HS must be given.

References:

1. Balan U., Gonsalves N., Jose M., Girish K. Symptomatic changes of oral mucosa during normal hormonal turnover in healthy young menstruating women / *Contemp. Dent. Pract.*– 2012.– No. 13 (2).– P. 178–181.
2. Dolgih O. V. Antiherpetic immunity at children and an exposition of xenogenic bonds / Dolgih O. V., Alekseyev V. B., Kiryanov D. A. and others // *Medical immunology.*– 2009.– T. 11.– No. 4–5.– 383 c.
3. Fatahzadeh M. Primary oral herpes: diagnosis & management // *J. N.J. Dent.*
4. Leontyev V. K., Kiselnikova L. P. Child therapeutic dentistry. National manual / M.: GEOTAR–Media,– 2010.– 896 p. (“National manuals” series).
5. Nelovko T. V., Mekhtiyeva R. R., Ivashenko Yu. Yu. Prophylaxis of a herpetic stomatitis at children of preschool age // *Saratov scientific–medical magazine.*– 2011.– T. 7.– No. 1 (app.).– P. 252.–255.
6. Pochtar V. N., Makedon A. B., Skiba V. Ya. Clinical implications of a herpes infection in odontology // *Clinical stomatology.*– 2008.– No. 4.– P. 18–21.
7. Shatokhin A. I., Volchkova Ye. V. Role of herpesvirus in a pathogenesis of inflammatory diseases of a parodont // *Stomatology.*– 2016.– No. 2.– P. 89–91.
8. Tidgen K. V., Urazova R. Z., Safina R. M. Acute herpetic stomatitis at children // *Practical medicine.*– 2013.– No. 4 (72).– P. 29–34.
9. Vilova K. G., Boyeva O. K., Vilova T. V. The analysis of the local acquired factors when forecasting a chronic recurrent herp // *International Journal of Applied and Fundamental Research.*– 2012.– No. 1.– 22 p.
10. Vinogradova T. F., Ginali N. V., Topolnitskiy O. V. Reference book on a children’s odontology / 2nd ed., changed and processed – M.: MEDpress–inform,– 2010.– 392 p.

*Ivanov Andrey Nikolayevich,
Dr. habil. in Medicine, senior researcher,
Department of Traumatology and Reconstructive Eye Surgery,
FSBO 'Helmholtz Moscow Research Institute of Eye Diseases',
E-mail: Road18@Yandex.ru*

*Alekseeva Irina Borisovna,
Dr. habil. in Medicine, senior researcher,
Department of Traumatology and Reconstructive Eye Surgery,
FSBO 'Helmholtz Moscow Research Institute of Eye Diseases',*

*Tankovsky Vladimir Eduardovich,
Dr. habil. in Medicine, senior researcher,
Department of retinal pathology,
FSBO 'Helmholtz Moscow Research Institute of Eye Diseases',*

TACTICS OF YAG-LASER VITREOLYSIS FOR 20 YEARS

Abstract: The work is devoted to non YAG-Laser surgery, which is used for traumatic genesis hemophthalmia treatment, during 20 years practice.

YAG-Laser vitreolysis is a select operation or an independent unit. YAG-laser destruction on vitreous reduces the time of treatment of traumatic hemophthalmia.

Keywords: YAG-laser vitreolysis, traumatic hemophthalmia.

Introduction. The vitreous body is a highly differentiated connective tissue, the main macromolecular components of which are water, collagen, hyaluronic acid, which ensure the metabolism of the vitreous body itself and the intraocular structures in contact with it [1, 7]. Changes in the vitreous body with violation of its transparency occur with mechanical eye injuries, uveal processes and hemorrhages in the vitreous body, when fibrinous exudation is observed with the organization of inflammatory exudate and blood. This contributes to the development of proliferative vitreoretinopathy followed by detachment of retina and ciliary body, and by development of phthisis bulbi [2, 3].

Eliminating hemophthalmia is one of the stages of organ resuscitation. Blood exuded into the vitreous body has a toxic effect on the eye structures, causing dystrophic changes in the reticular membrane, secondary glaucoma and cataract. Organization with the formation of synechias leads to functional disorders in 47% of cases, while infection and hemoendophthalmitis in 5–7% result in anatomical death of the eye [4, 7].

Options for medical and surgical treatment, including YAG-laser destruction of inflammatory and post-

traumatic changes in the vitreous body, are diverse and determined by pathogenetic signs [6].

The medicamentous therapy of vitreous pathology, hemophthalmia in particular, takes a long time, while its final effect remains problematic; it is aimed at reducing the vascular response, resorption of exudate, prevention of synechia development and traction of internal membranes [7, 8].

One of the leading methods for treating vitreous and retinal pathologies is closed vitrectomy, which was first offered by R. Machemer in 1971 and attracted attention with its effectiveness. At present, total or partial vitrectomy is used [3, 4], providing a rapid effect in 32–67% of cases [4].

However, in a number of cases formation of synechias, especially in the anterior parts of the vitreous body, obstructs and complicates vitrectomy [4, 5, 6, 7].

Laser ophthalmic surgeons conducted a search for methods of affecting the vitreous body without opening the eyeball. Nd: YAG laser intervention is atraumatic [7, 8, 11], short-term and allows to dissect or prevent the formation of synechias, prevent neovascularization of the membranes and toxic damage to the inner membranes of the eyeball [7, 8, 9, 10, 11].

To justify the validity of applying Nd: YAG laser exposure on the vitreous body as preparation for vitrectomy, we hereby present some data.

Fankhauser F. (1983) used Nd: YAG laser to form an optical channel with weakening vitreous body traction in cases of retinal detachment [10, 11]. That was the time, when the term YAG laser vitreolysis was introduced.

A number of authors believed that Nd: YAG laser surgery of the vitreous body cannot be an independent unit, but only a fragment of surgical vitrectomy [2, 11]. But, at the same time they pointed out that in order to reduce the traction of the vitreous body it is better to use Nd: YAG laser in the middle or posterior part of the vitreous body, the so-called 'rear vitreolysis' [10], with an efficiency of 30–65%.

In 1991, the works of Stepanov A. V., Ivanova A. N., Khoroshilova-Maslova I. P. proved that Nd: YAG laser exposure of the vitreous body is accompanied by dilution of the vitreous body structure, appearance of enzymes in the vitreous body and by increase of hydro circulation in the vitreous body [8].

Thus, the available data suggested prospectivity of carrying out Nd: YAG laser vitreolysis or Nd: YAG laser destruction of pathological vitreous body formations with increased fibrinolysis for the treatment of vitreous body pathology caused by hemophthalmia.

We have for the first time recommended and obtained RF patents for the invention in the sphere of YAG-laser treatment methods for vitreous body pathologies with endophthalmitis and hemophthalmia (RF patents for invention No. 2136251 as of 05.11.1996, No. 2180204 as of 22.02.2000).

The materials presented are reflected in the works for Candidates of medical sciences Ivanova A. N. (1987), Bolkvadze E. R. (2004), Degtyareva E. M. (2012) and holders of Habilitation degree in Medicine Stepanova A. V. (1990), Ivanova A. N. (2003).

The purpose of research was to present the results of non-invasive YAG laser treatment of hemophthalmia (Nd: YAG laser vitreolysis), which can prevent development as well as destroy vitreous body synechias and cause lysis of hemophthalmia.

Materials and methods. A 'Visulas-YAG II' laser device by 'Karl Zeiss' (Germany) company was used for the Nd: YAG laser action. The pulse energy was 0.8–9.2 mJ, the number of pulses was from 2 to 150, depending

on the density of the destructive process and the distance from the lens and the retina; number of sessions was 3–12. The criterion for the end of a session was the condition of the vitreous body – the saturation of the destroyed elements of blood, exudate and their ratio to the eye membranes as well as the maximum total energy of the Nd: YAG laser exposure up to 700 mJ, which was calculated in experimental studies [9].

We observed 251 patients (251 eyes) with hemophthalmia (212 men (84.5%) and 39 women (15.5%)).

The time of the first Nd: YAG laser intervention was between the first and 126th day (mean time of 17.4 days) after appearance of hemophthalmia. The energy of the Nd: YAG laser exposure was 0.8–9.2 mJ, with an average of 6.2 mJ, the number of pulses was up to 150, the number of sessions was up to 12.

After the clinical examination and localization of hemophthalmia using ultrasonic methods of research (volume, acoustic density of opacities in the vitreous body), the patients, on the background of maximal mydriasis and under local anesthesia, had a Nd: YAG laser exposure of the vitreous body performed in a mode that causes motion (circulation) inside the vitreous body and destruction of blood conglomerates, thereby enhancing the lysis of blood. If necessary, the session is repeated until the density of the hemophthalmia decreases, while the energy of the Nd: YAG laser exposure is increased from sparing (without causing any damage to vitreous body fibrils) up to obliterating for the destructive formations. In between sessions, instillations or injections of corticosteroids are prescribed, and IOP control is also performed.

Results and discussion. Nd: YAG laser irradiation on hemophthalmia led to destruction of the vitreous body synechias of various density, destruction and lysis of blood conglomerates. Density reduction observed, according to data obtained with ultrasound, was more than 80% in 184 cases (73.3%). However, the recurrence of hemorrhage was noted in 8 cases (16%). The presence of residual finely dispersed suspension is considered normal in patients who underwent late Nd: YAG laser destruction of organized synechias and conglomerates of the vitreous body.

Such a considerable difference in terms of treatment after formation of hemophthalmia is explained by terms of seeking medical aid by patients as well as by the fact

that the outcomes of the organization are also adequately fragmented and then subjected to active lysis after Nd: YAG laser action.

Among patients who underwent Nd: YAG laser treatment without conservative hemolysis reinforcing treatment, lysis of hemophthalmia was completed on days 12–45 (average term made up 26.6 days), and in the group where this treatment was applied on days 9–33 (17.2 days). It also should be noted, that the therapeutic effect of blood hemolysis in the vitreous body is shown at half of the drug dose recommended for standard applications.

In 23 cases (9.2%) there was observed a rise in IOP up to 28–34 mm Hg, of which 17 cases required Intensive antihypertensive therapy. Nd: YAG laser treatment of hemophthalmia was continued after IOP compensation, but with a decrease in energy parameters.

Laser power was also reduced in cases of recurrent hemorrhage, while the number of laser sessions was increased.

Gentle mode was also used in cases, when there were marked concomitant complications in the eye structures.

The hemolytic effect of Nd: YAG laser exposure was also observed in the absence of visible destructive action, in fact, at irradiation without any pulsed discharges.

Upon completion of laser action, 70% of patients had vitrectomy performed. We applied the 25G three-port

technique and the aspiration mode against the background of the liquefaction of the vitreous body in 83% of cases.

The control electrophysiological screening after Nd: YAG laser exposure of the vitreous body showed a 35% less reduction in retinal parameters, than after vitrectomy with preliminary laser exposure.

In the control group, vitrectomy was performed on 50 patients (50 eyes) without any laser exposure of vitreous body.

The 20–25G three-port technique was used. A 5700 silicone oil was administered at the end of the surgery. The recurrence of hemorrhage was observed in 8 cases (16%).

Conclusions. 1. Nd: YAG laser exposure of the vitreous body is effective in case of hemophthalmia and causes its destruction, followed by lysis and liquefaction of the vitreous body.

2. Nd: YAG laser exposure of the vitreous can be either an independent surgical treatment or an additional one for the surgical or conservative treatment of hemophthalmia.

3. Vitrectomy is considerably easier performed after Nd: YAG laser destruction of hemophthalmia.

4. Nd: YAG laser exposure reduces the amount of medications for the treatment of hemophthalmia, as well as the period required for its treatment.

References:

1. Махачева З. А. Анатомия стекловидного тела. Офтальмохирургия. – 1994. – № 2. – С. 38–42.
2. Бойко Э. В. Автореф. дисс. ... канд. мед. наук Санкт-Петербург, – 1994. – 21 с.
3. Чичуа Г. А. Дисс. ... канд. мед. наук – Москва, – 1997. – 156 с.
4. Лебединская О. Н. Автореф. дисс. ... канд. мед. наук – Москва, – 1997. – 19 с.
5. Тульцева С. Н. Автореф. дисс. ... канд. мед. наук – Санкт-Петербург, – 1996. – 21 с.
6. Иванов А. Н., Танковский В. Э., Мизерова О. В. ИАГ-лазерная деструкция экссудата в передней камере с артифакцией и ИАГ-лазерный витреолизис у больных с увеитами. Вестник Оренбургского государственного университета, – № 4 (153). – апрель, – 2013, материалы XXIV Всероссийской научно-практической конференции с международным участием 'Новые технологии микрохирургии глаза', – С. 102–104.
7. Степанов А. В., Иванов А. Н. Лазерная хирургия стекловидного тела. Вопросы лазерной офтальмологии / под ред. А. В. Большунова. – М: Апрель, – 2013. – 316 с., Глава 20, – С. 256–269.
8. Хорошилова-Маслова И. П., Андреева Л. Д., Степанов А. В., Иванов А. Н. Морфологические изменения тканей глаза при воздействии ИАГ-лазера. Офтальмологический журнал. – 1991. – № 6. – С. 347–351.
9. Aron-Rosa D., Griesemann D. A. Neodymium: YAG laser microsurgery: fundamental principles and clinic applications. Int. Ophthalmol. Clin. – 1985. – Vol. 25. – No. 3. – P. 125–134.
10. Fankhauser F., Kwasniewska M. S., Van der Zypen. Irradiation of the posterior ocular segment with the Neodymium: YAG laser in its free-running mode. Arch. Ophthalmol. – 1985. – Vol. 103. – No. 8. – P. 1406–1412.
11. Fankhauser F., Kwasniewska S., Laser Vitreolysis. A review. Ophthalmologica. – 2002. – Vol. 216. – No 2. – P. 73–84.

*Iskandarova Shokhista Fekhruzovna,
doctor, of sciences in pharmaceutical,
associate professor, of the Tashkent pharmaceutical institute*

E-mail: iskandarova.shakhista@mail.ru

*Dzhabbarov Nurilla Abdumakhsudovich,
assistant, of the Tashkent pharmaceutical institute*

E-mail: Nuri_jna@mail.ru

*Umarova Shakhnoz Ziiyatovna, PhD,
associate professor, of the Tashkent pharmaceutical institute*

E-mail: umarova.shakhnoz@mail.ru

THE TECHNOLOGY OF OBTAINING THE DRY EXTRACT FROM THE FRUITS OF SOPHORA JAPANESE (SOPHORA JAPONICA L.) BY MODERN ACCELERATED METHOD

Abstract: This article presents the results of the development of the technology for obtaining the dry extract from Sophora Japanese fruit (*Sophora japonica* L.). A stepwise process for obtaining the dry extract using the technological scheme is described.

Keywords: *Sophora* Japanese (*Sophora japonica* L.), technology, dry extract, technological scheme.

The production of extracts from raw materials of plant origin is a priority area of the domestic pharmaceutical industry. The most important task of processing medicinal plant raw materials is to preserve the whole complex of biologically active plant substances. Natural plant biologically active substances are the best alternative to synthetic substances, since they are evolutionarily closer to the human body, practically do not cause side effects and are easily involved in metabolic processes. In this case, the value of medicinal properties of medicinal plants is exclusively in synergetic effect from the effect of the whole complex of active substances of plants. The positive effect of such an impact is several times higher than that of each element individually.

Japanese Sophora (*Sophora japonica* L.) is a large deciduous tree with a sprawling spherical crown. It has powerful bactericidal and anti-inflammatory properties, as well as a pronounced antioxidant effect. It is known as a beautiful ornamental and honey plant. Japanese Sophora contains a large number of flavonoids, especially rutin. Fruits and flowers (buds) are much richer with rutin, but in the latter it is almost twice as large. In the buds of Sophora, there are also other flavonoids – sophorin A and B, essential oil, carbohydrates: in fruits-sfo-

roside, resinous substances. The alkaloid composition of Sophora has been studied most well, pachycarpine, matrin, and cofocarpine are found in leaves – 3%, fruits and seeds – 4%, roots 2–3%. In addition, the roots contain phenolic coloring substances, in seeds – up to 6% fatty oil. In addition, bioactive substances are isolated from different parts of Sophora: kaempferol, quercetin, flavonoids, organic acids and vitamin C [2].

In scientific medicine, rutin is widely used for the prevention and treatment of anemia, hypo- and avitaminosis P, in diseases accompanied by impaired vascular permeability. Rutin is also used in the medical practice of many countries, in particular, Bulgarian physicians use it in the treatment and prevention of hemorrhages, especially the brain, heart and retina of the eyes, diabetes mellitus, sclerotic vascular wall damage, hypertension, hemorrhagic diathesis, kidney disease, rheumatism, ulcerative colitis [1, 3, 4].

Proceeding from the foregoing, the purpose of our research was the development of technology of dry extract from Japanese Sophora fruit.

The research was carried out at LC “Balzam”. In this production there is a modern extractor “Ruian Xuanli machinery Ltd”, which for a short time filters the extractant

through plant material in order to extract substances soluble in the extractant. This extractor consists of:

- The main reservoir – an extraction tank that checks the main scheme: it is mainly used for extracting the effect element on phytotherapy;

- Condenser: mainly used for the return flow of condensed liquid to the extraction tank;

- Vacuum condenser: used to concentrate and collect the extracted paste. And also a tank for collecting the solvent: it is used as a collector.

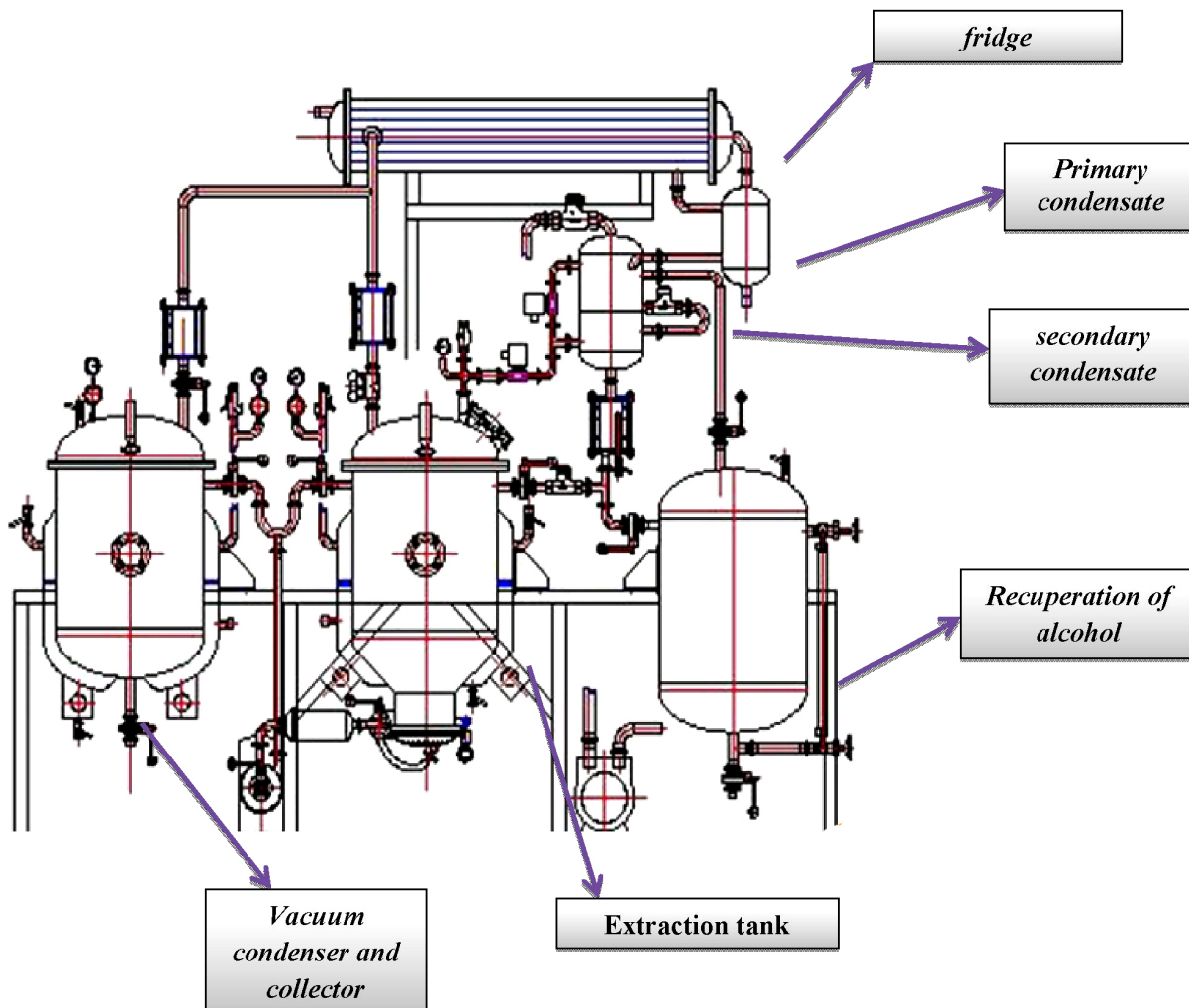

Figure 1. Extractor “Ruian Xuanli machinery Tank”

With these data, the extractor can simultaneously perform several functions, such as temperature control, ultrasound, vacuum, condenser, recuperation, alcohol, etc.

At the beginning of the work with the extractor “Ruian Xuanli machinery Tank”, we obtained the dry extract by the following sequence.

To obtain the dry extractor of 7 kg of fruit, the Sophora was ground, sieved and loaded into a pre-prepared percolator. Then 70% ethyl alcohol was poured into the percolator and heated to 50 °C, left for 4 hours. Then, the ultrasound was turned on for 10 minutes. The resulting extracted liquid was transferred to a vacuum

condenser and a collector. It turned out 70 liters of liquid extract. An additional process of our technological process in obtaining the dry extract in production is the drying stage, which we carried out in the spray dryer “LPG-15 Spray dryer”.

Most clearly, the volume and sequence of work, as well as the specificity of a particular production, show technological schemes that are an indispensable element of industrial regulations for the production of:

The resulting dry extract is a yellow friable powder with a characteristic odor. The yield of the dry extract from the Sophora Japanese fruit was 20.4%.

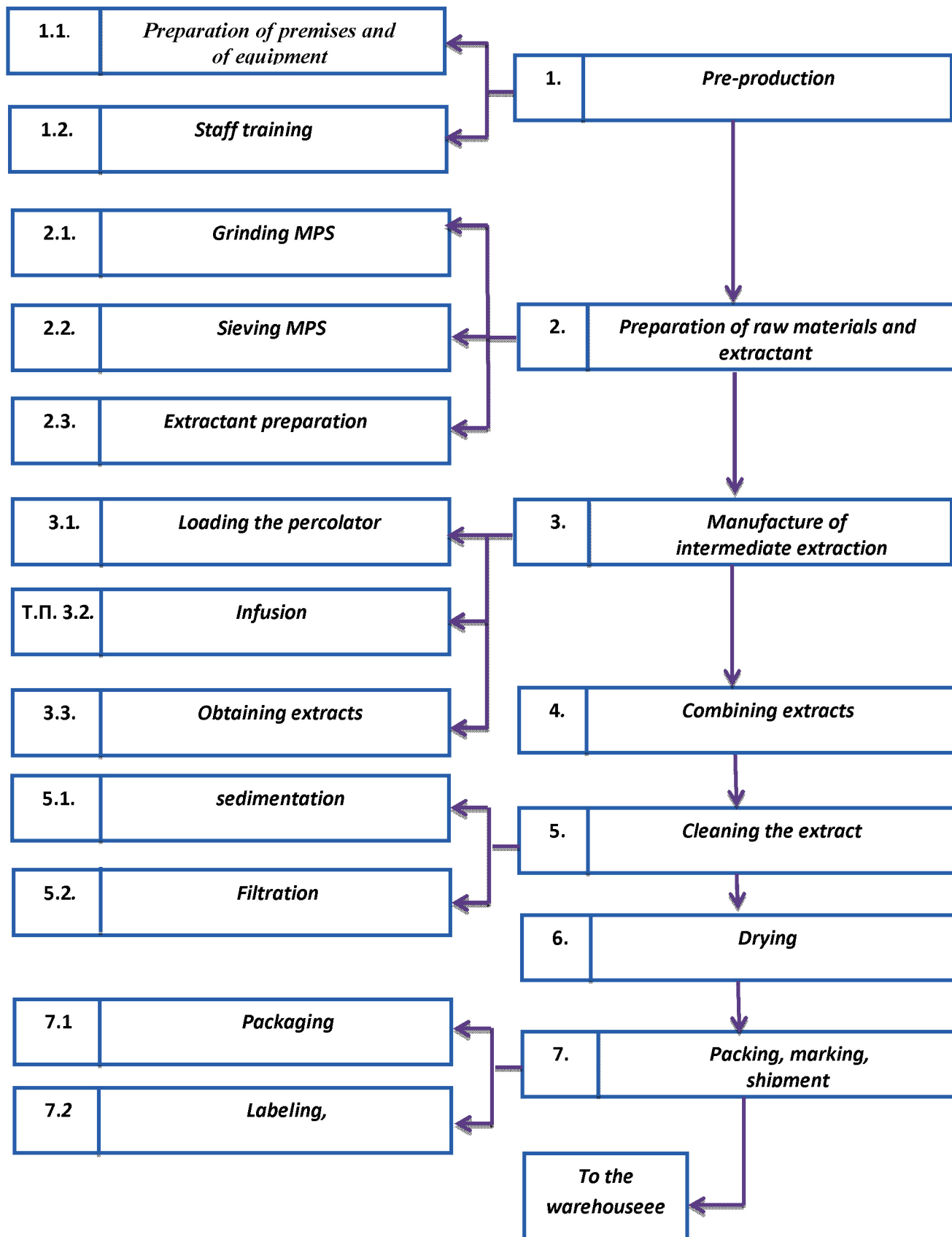

Figure 2. Technological scheme of dry extracts production

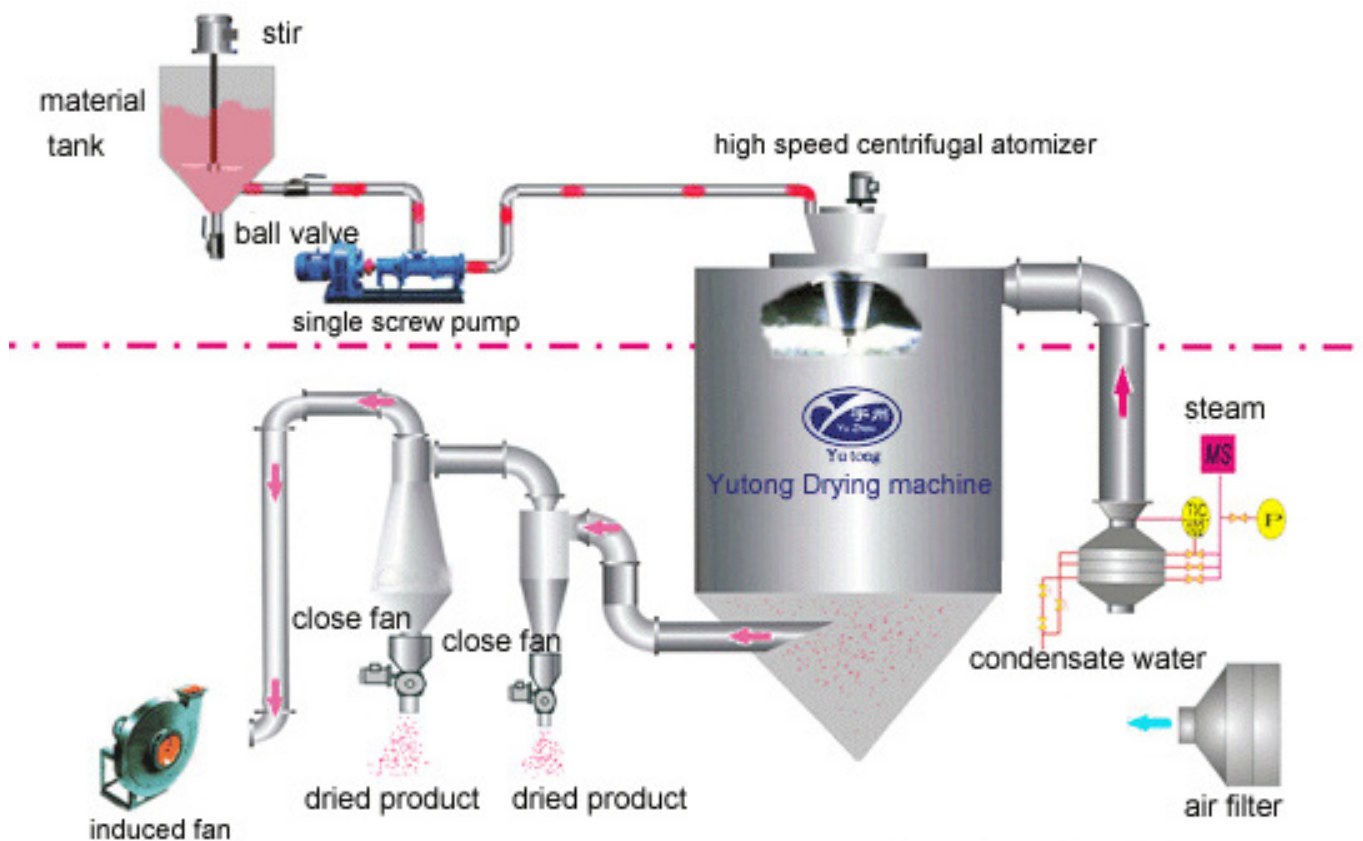

Figure 3. Spray dryer “LPG-15 High Speed Spray dryer”

References:

1. Дрозд Г. А. Фармакогностическо-иммунологическое изучение плодов софоры японской (*Sophora japonica* L.) / Д. А. Дрозд, Л. А. Горбачева // Фармация. – 1994. – № 1. – С. 34–37.
2. Ковалева Л. Г., Сампиев А. М. Исследование фенольных соединений плодов софоры японской // Современные проблемы науки и образования. – 2013. – № 6.
3. Studies on antihemorrhagic substances in herbs classified as hemostatics in Chinese medicine. On the antihemorrhagic principle in *Sophora Japonica* / Ishida H. et al. // Chem. Pharm. Bull. – 1987. – Vol. 35. – No. 2. – P. 857–860.
4. The antiulcer action of sophora and the active constituent in Sophora. The antiulcer action of vexibinol / Yamahara J. et al. // Chem. Pharm. Bull.: – 1990. – Vol. 38. – No. 4. – P. 1039–1044.

*Iskandarova Shokhista Fekhruzovna,
doctor, of sciences in pharmaceutical,
associate professor, of the Tashkent pharmaceutical institute*

E-mail: iskandarova.shakhista@mail.ru

*Mamatkulov Zukhrudin Urmonovich,
assistant, of the Tashkent pharmaceutical institute*

E-mail: mzu_77@mail.ru

DETERMINATION OF POLYPHENOLIC COMPOUNDS IN THE DRY EXTRACT OBTAINED FROM THE LEAVES OF CAPERS SPINY (CAPPARIS SPINOSA)

Abstract:

Keywords:

Currently, in the pharmaceutical industry, the development and standardization of medicines and biologically active additives based on plant raw materials are one of the priority areas. Based on this, the purpose of our studies was to determine the quantitative content of polyphenolic compounds in the dry extract obtained from the leaves of capers spiny (*Capparis spinosa*).

For the research, the raw materials collected in the Fergana Valley were used. According to the literature, it is known that the fruits contain about 18% of proteinaceous substances and about 36% of fats, in seeds – p to 30% of oils. In the fruits are found thioglycosides, steroid saponins, rutin (up to 0.3%), ascorbic acid (up to 136 mg/100 g), coloring substances; in the roots – glycoside capparidin and alkaloid stachidrin. In fruits, there is a fairly large amount of iodine (up to 27 mg/100 g in terms of dry weight).

Flower buds contain ascorbic acid (100–150 mg/100 g), rutin (0.32%), nitrogenous substances (21–29%), fatty substances (3.8–4.6%), essential oil, pectin.

Seeds contain up to 18% of protein, (semi-drying fatty oil of red color (25–35%), consisting of saturated (12%) and unsaturated (oleic – 22–24%, linoleic – 34–51%) fatty acids [1, 2, 3].

To obtain the dry extract, three different extractants were used: 40 and 70% ethyl alcohol, chloroform. The dry extract was obtained by the repercolation method in the following sequence:

– 100 g of crushed capers leaves were extracted five times with 40% ethyl alcohol. The resulting fluids were then combined and concentrated. To purify the thick extract from resinous and chlorophilic substances, it was extracted three times with chloroform. The resulting thick solution was dried in a spray dryer of the nozzle type “Anhydro No. 2” (Denmark).

– 100 g of crushed capers leaves were extracted five times with 70% ethyl alcohol. The resulting fluids were then combined and concentrated. To purify the thick extract from resinous and chlorophilic substances, it was extracted three times with chloroform. The resulting thick solution was dried in a vacuum – drying cabinet “CDV – 45K” (Russia).

– 100 g of crushed capers leaves were extracted three times with chloroform. The resulting fluids were then combined and concentrated. The resulting thick solution was purified from resinous substances and left for a day to dry.

It is known that polyphenolic compounds are of great importance in medicine. On this basis, further experiments were aimed at studying the quantitative content of polyphenolic compounds in the resulting dry extract.

Water – alcohol extraction of plants and collection. Samples were extracted in a ratio of 1 g:10 ml of 70% ethanol in an ultrasonic bath at a temperature of 40 °C, for 1 hour, once. The liquid portion of the extract was prepared for chromatographic analysis.

HPLC analysis of phenolic components. HPLC was carried out with an Agilent 1200 chromatograph equipped with a programmable UV detector, reversed phase column C18 measuring 15 × 0.46 cm, 3.5 mmK, mobile phase: “A” – 1% acetic acid; “B” – a mixture of acetonitrile and methanol in a ratio of 6:4; The chromatographic profile was recorded at 370 nm (optimally for FLS) and 330 nm (for FCC). The program

for the pump: from 0 to 1 min – 2% “B”; from 1 to 10 min gradient “B” to 60%; from 10 to 13 minutes 60% of “B”; from 13 to 20 min gradient “B” to 98%; from 20 to 23 minutes 60% “B”; from 23 to 24 minutes the inverse gradient “B” to 2%; flow rate 1 ml/min, assay time 25 min. Chromatographic analysis and subsequent processing of data was carried out using the program “Chemstation” (Agilent, USA).

C_spinosa dry leaves extract

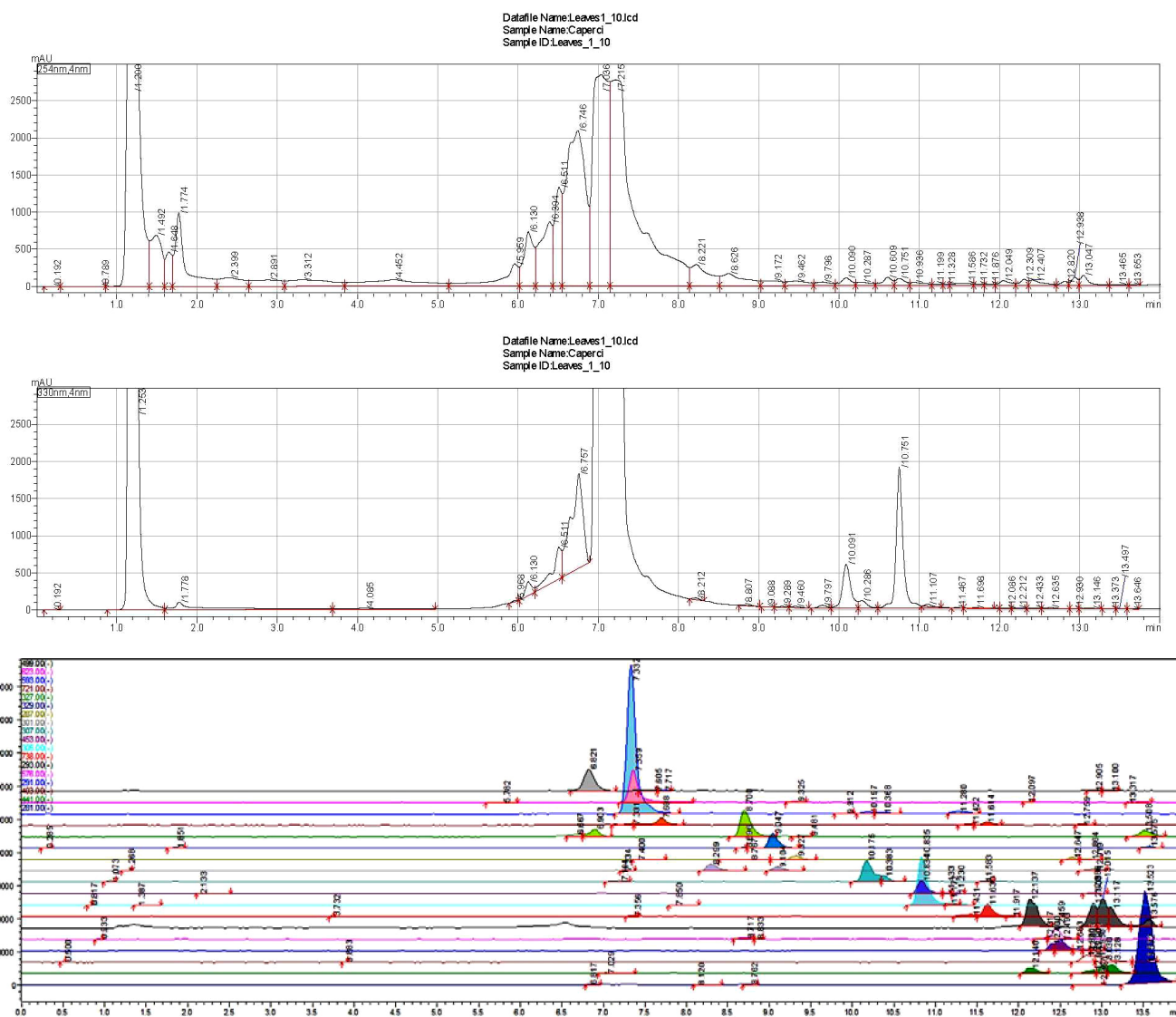

Figure 1. 70% Ethanol extract of dry leaves (1:10; 95 C; 15 min)

Total phenolics (Gall ac. std; in per 100 g of dry leaves) = 16.42%

Total flavonoids (Quercetin std; in g per 100 g of dry leaves) = 4.7%

Main constituents:

Rutin (2.8%); Quinic acid derivatives; free quercetin; free kaempferol;
Unknowns m/z 623/593;721;441;453 (phenolics); 293; 281

HPLC – MS analysis of phenolic components. HPLC – MS was performed with an Agilent 1260 infinity chromatograph combined with an Agilent 6400 triple quadrupole mass spectrometer. Chromatographic separation was performed on a column C18 measuring 10 × 0.2 cm, 1.8 mm. Mobile phase: “A” – 0.1% formic acid; “B” – a mixture of acetonitrile and methanol in a ratio of 6:4; program for the pump: from 0 to 1 min – 2% “B”; from 1 to 10 min gradient “B” to 60%; from 10 to 13 min 60% “B”; from 13 to 20 min gradient “B” to 98%; from 20 to 23 minutes 60% “B”; from 23 to 24 minutes the inverse gradient “B” to 2%; flow rate 0.25 ml/min, time of analysis 25 min. The chromatography profile was monitored by recording the total ion current (TIC). Gas dehumidi-

fier – nitrogen 4 ml/min, 300 ° C, ionization by electro – sputtering (ESI) in two modes – ESI and + ESI, voltage of fragmentator 100 V. Scanning of ions – within m/z values of 100–2000.

Identification of the components was carried out by coincidence of the retention time of peaks of standard substances and the corresponding peak in the chromatogram of the extracts under study in the presence of standards and on the values of m/z corresponding to the quasimolecular ion.

Positive results were obtained in the dry extract, where 70% ethyl alcohol was used as the solvent. The amount of polyphenolic compounds was 16.42%.

References:

1. Chalak L., Elbitar A. Micropropagation of *C. spinosa* L. subsp *rupestris* Sibth and Sm by nodal cuttings. *Indian J Biotechnol.* – 2006. – 5(4). – P. 555–8.
2. Inocencio C. D., Rivera F., Alcaraz A., Tomas B. Flavonoid content of Commercial capper (*C. spinosa* L., *C. sicula* and *orientalis*) produced in Mediterranean countries. *Euro Food Res Technol.* – 2000. – 212 p. – P. 70–4.
3. Sozzi G. O., Vicente A. R. *Capers and caperberries*. Handbook of herbs and spices. USA: Woodhead Pub; – 2006.

*Kurbanazarov Muratbai Kunnazarovich,
Head of the Surgical Diseases Department
of the Nukus Branch of the Tashkent Pediatric Medical Institute*

*Abdullaeva Nuria Zhalgasovna,
assistant, of the Department of Surgical Diseases of the Nukus Branch
of the Tashkent Pediatric Medical Institute*

*Palekeeva Gulzhakhan Parahatovna,
assistant, of the Department of Surgical Diseases of the Nukus Branch
of the Tashkent Pediatric Medical Institute*

E-mail: evovision@bk.ru

EVALUATION OF THE STATE OF EXTRA-SCOPE PATHOLOGY AT CHILDHOOD IN CHILDREN IN THE SOUTHERN REGION OF ARAL

Abstract: In parallel with the deterioration of the ecological situation, there were high rates of registration of morbidity in the South Priaralye region. Risk factors that determine the changes in the functional state of the human body are singled out, which reduces its stability, depletes the protective forces, strengthens the pre-pathological conditions, and exacerbates infectious processes. In the region with increased influence of environmental and climatic factors, high rates of extracardiac pathology in children with myopia are noted.

Keywords: Priaralye, ecology, myopia in children and adolescents, concomitant diseases.

Despite numerous studies, myopia remains one of the most common pathologies in ophthalmology. The data of the scientific literature shows that the frequency of occurrence of myopia in children and adolescents in different countries ranges from 20–30 to 60–80% of the total incidence. Myopia suffers from 28.4 to 35% of the world's population, of which high-grade myopia is noted in 4–9% [1, 5, 8]. On the other hand, the territory of the southern Aral Sea is recognized as an ecologically unfavorable region, in connection with the deterioration of the quality of drinking water, pollution of atmospheric air and soil, high incidence rates in the South Priaralye region have been registered in parallel [2, 4, 6, 7, 8]. Risk factors that determine the changes in the functional state of the human body are singled out, which reduces its stability, depletes the protective forces, strengthens the pre-pathological states, and exacerbates infectious processes [2, 6, 7]. The data of the literature testify that with prolonged observation of children with myopic refraction, it was possible to trace a clear connection between the presence of common diseases and the deterioration of the state of the accommodative apparatus [1, 7, 8].

In this regard, the opinion was expressed that the influence of many unfavorable factors is mediated through the accommodation apparatus. Factors contributing to the development of myopia and its progression in more than 70% of cases is the weakness of accommodation [6, 7].

Objective: to study the presence and frequency of concomitant pathology in children with myopia in certain regions of the Southern Aral region.

Material and methods of the study: ophthalmic status 52 (congenital form 11, acquired-41) of sick children aged 1–18 years old (Nukus, Khodjeyli, Kanlykul, Shumanay, Kegeili) and 50 patients (congenital-12, acquired-38) of the same age of the northern (Chimbay, Karauzyak, Takhtakupir) regions of the southern Aral Sea region. The territory of the Republic of Karakalpakstan due to the impact of environmental factors and socio-economic conditions is divided into the coastal, northern, central and southern zones, in connection with which the studies were carried out on the zones of the region [3]. According to the data of the SGS, in the last 5 years, the pollution of drinking water in 33.7%, pollution

of air in 41.4% of samples in the northern zone, which are 7.8% and 24.6% in the central zone. Ophthalmic examinations, such as vidiometry, refractometry, ophthalmoscopy and outpatient card data for the development of the child f-112-y have been carried out. Statistical processing was carried out under the EXCEL program.

Results of the study: Central zone. Concomitant diseases are an unfavorable background, affecting the development and clinical course of myopia. The percentage of healthy children with acquired nearsightedness was 23.8 (10 patients), the main part of which suffer from concomitant diseases: iron deficiency anemia 11 (26.1%), upper respiratory tract pathology 7 (16.6%), infectious hepatitis 5 (11.9%), hypothyroidism 5 (11.9%), pathology of the genitourinary system 4 (9.5%). While 3 (27.2%) healthy children were observed with congenital myopia, and among the concomitant diseases, iron deficiency anemia 3 (27.2%), congenital anomalies 3 (27.2%), with pathology of the upper of the respiratory tract 1 (9.0) of the patient and also one patient (9.0%) suffered an infectious hepatitis in the anamnesis. Anisometropia up to 3.0 AD was detected with acquired myopia in 7 eyes (8.4%) and with congenital myopia in 2 eyes (9.0%), anisometropia more than 3.0 Dpt. with near-term myopia diagnosed on 2 eyes (2.4%) and congenital also in 2 eyes (9.0%).

Thus, with acquired myopia, astigmatism was observed in 25.3% of cases (21 eyes), while in congenital myopia 36.3% (8 eyes), anisometropia with acquired near-sight was detected in 10.8% of cases (9 eyes) and with congenital myopia in 22.7% of cases (5 eyes). Astigmatism with congenital myopia was observed more often than with acquired myopia: up to 2.0 doses 1.2 times more often (18.1%), up to 3.0 d in 1.6 times (13.6%) and more than 5.0 D. 1.8 times (4.5%). The magnitude of anisometropia to 3.0 D. in congenital myopia is 1.0 times greater (9.0%), more than 3.0 times 3.7 times more often (9.0%) than with acquired nearsightedness.

Northern zone. It is important to note that only one child is identified that does not suffer from concomitant pathology, and in most children with acquired form of myopia an extraocular pathology is observed: iron deficiency anemia in 12 (31.5%) patients, bronchitis in 8 (21.0%) children, hepatitis in 7 (18.4%), 5 (13.1%) patients had nephritis and 5 (13.1%) hypothyroidism. While with congenital myopia, all children had concomitant diseases, among them 5 (35.7%) patients had iron deficiency anemia, congenital anomalies in 4 (28.5%) patients. In 2 children (14.2%), bronchitis and infectious hepatitis were detected, in 1 patient (7.1%) the patient had endemic goiter.

Thus, in the region with high rates of air and drinking water pollution extraocular pathology is noted more often than with lower indicators of environmental pollution. With the acquired myopia, astigmatism was observed in 43.2% of cases, while in congenital myopia 60.7% was 1.4 times greater, anisometropia with acquired near-sight was detected in 14.8% of cases (11 eyes) and in 1.7 times more often with congenital myopia in 25.0% of cases (7 eyes). Astigmatism was more often observed with congenital myopia, up to 2.0 doses 1.3 times more often (32.1%), up to 3.0 D in 1.7 times (21.4%) and more than 5.0 doses in 1, 7 times (7.1%). The magnitude of anisometropia to 3.0 D. in congenital myopia is 1.3 times greater (14.2%), more than 3.0 times 1.9 times more often (10.7%) than with acquired nearsightedness.

Conclusions: 1) a correlation between the presence of myopia and extraocular pathology in children was revealed; 2) there are high rates of myopia with a predominance of astigmatism and anisometropia in the zone where there is a deterioration in the ecological situation; 3) a higher incidence of extraocular pathology in children with myopia in an ecologically unfavorable region was detected; 4) it is necessary to develop preventive measures depending on the state of the environment.

Referenes:

1. Avetisov E. S. Myopia. – Moscow: Medicine, – 2002. – 285 p.
2. Atanizova O. A., Konstantinova L. G., Yeshanov T. B. The Aral crisis and medical and social problems of Karakalpakstan. – Nukus, – 2001. – 116 p.
3. Kurbaniyazov A. B. Formation and development of labor resources in Karakalpakstan. Nukus. “Karakalpakstan”. – 1991. – 192 p.
4. Baranov A. A., Ignatyeva R. K., Kagramanov V. I. Ecological and medico-demographic problems of the Aral Sea region and the state of health of the child population in this region // Pediatrics – No. 5. – 1993. – P. 76–79.

5. Mamatkhujueva G. N. The prevalence of refractive error among schoolchildren // *Bulletin of Ophthalmology.*– 2002.– No. 1.– P. 47–49.
6. Mambetullaeva S. M. Multifactor analysis of environmental parameters affecting the state of health of children in environmental crisis // *Environmental factors and maternal / child health in the Aral Sea crisis region: Proceedings of the international seminar.*– T.,– 2001.– P. 116–118.
7. Niyazova G. T., Shelepova O. G., Atakhanova D. Priority pollutants of the components of the environment of children in Nukus // *Journal of Theoretical and Clinical Medicine.*– 2006.– No. 4.– P. 42–43.
8. Sidikov Z. U., Ashirmatova Kh. S., Fazylova Z. A. Identification and analysis of the incidence of ocular pathology in the population of Navoi, Samarkand and Karakalpakstan regions // *Actual problems of eye microsurgery: Abstracts of the scientific and practical conference.*– Tashkent,– 2011.– P. 29–30.

*Madazimov Madamin Muminovich,
M.D., associate professor, of hospital surgery,
anesthesiology and reanimation faculty of the Andijan
State medical Institute
E-mail: plastic62@bk.ru*

*Kayumhodjaev Abdurashit Abdusalamovich,
M.D., head of the Department of Plastic and
Reconstructive Microsurgery of the Republican
Specialized Center of surgery named after Academician V. Vahidov,
E-mail: kaumhodjaev.flap@mail.ru*

*Madazimov Komil Madaminovich,
assistant, of faculty, hospital surgery, anesthesiology
and reanimation of the Andijan State medical Institute
E-mail: komil-madazimov@inbox.ru*

*Teshaboev Muhammadyahyo Gulomkadyrovich,
Ph D., assistant of faculty, hospital surgery, anesthesiology
and reanimation of the Andijan State medical Institute
E-mail: teshaboev2013@mail.ru*

SURGICAL APPROACH TO TREATMENT OF PATIENTS WITH CONSEQUENCES OF THE CRANIAL VAULT BURNS

Abstract: The author of the article highlights the methods of surgical approach in patients with consequences of burns in the area of the cranial vault. This article presents the results of surgical treatment of 76 patients with different approaches. Patients were divided into two groups, control and main. Good and satisfactory results of surgical treatment in the main group of patients were observed in 90.2%, which was higher than the parameters of the control group (85.6%).

Keywords: surgical approach, consequences, cranial vault, burns.

Background information. Approximately 6,000,000 people per year around the world are appointed for medical care due to burns [2, 4].

In our Republic, about 18,000 (out of 32 million) of the population receive burns every year.

Deep burns of the scalp are found in 15% of patients who received thermal trauma. The resulting burn soft tissue defects are one of the most tragic consequences of underwent burn injury [3, 5].

Some patients who seek help have soft tissue defects with the exposure of the bones of the cranial vault or the defect of soft and bony tissues with the exposure of brain tissue, which requires the application of immediate patchwork with the help of microsurgery, combined plastics or "the Filatovs stalk". In this case, only the skin-

fat layer is restored, but alopecia remains, as well as the problem associated with it [1, 4]

Materials and methods of research. The work is based on the results of surgical treatment of 76 patients with post-burn cicatricial defects and deformities of the cranial cervical area in the department of the consequences of injuries of the multifield medical center of Andijan region. Their age of the patients ranged from 4 to 61 years. Of these, 24 (31.8%) are male and 52 (68.2%) are female. 54 patients of the main group and 22 patients of the control group. The main damaging factors were hot fluid – 23 (30.2%) and contact burns – 19 cases (25%). Patients admitted the department at various times after the injury – from 5 months to 27 years after the healing of burn wounds.

Results and discussion. In order to effectively model the plasty of scarring alopecia and soft tissue defects of the cranial vault, they were subdivided into groups according to size: small (up to 120 cm², which was less than 25% of the scalp area), which occurred in 30 (40%) patients; average (121–250 cm²–25–40% of the scalp area), observed in 35 (46.6%) patients and large (more than 250 cm², ie more than 40%), used in 11 (13.4%) patients.

In the control group of patients, acute dermatosis was used in 7 patients, traditional expander plastics occurred in 15 patients.

In the main group of patients intraoperative rapid balloon stretching was used in 35 patients. Improved expander plastics in 19 patients.

In scarring alopecia with a width of up to 2.5 cm, 7 (9.2%) patients used the method of acute dermatension.

Long-term observations have shown that the method of acute dermatosis has the following disadvantages:

1. Teething of seams due to tension;
2. Possibilities of superimposing delayed seams in the case of defects in tissues for plastics;
3. Expansion of postoperative cicatrix in the long-term period in 71% of patients.

Due to this, we have studied the possibility of using intraoperative (rapid) balloon stretching of tissues in this group of patients.

15 patients had surgery with the method of traditional expander plasty. With defects of small and medium size, patients implanted one expander with a base size of 6 × 12 cm.

If the defect was more than 30% of the hair, two balloons were used.

In all patients, tissue stretching was performed on an outpatient basis.

Enhanced expander plastic $n = 19$ (25%).

The advantages of this method

1. Expander implantation through a wide incision allows visually monitoring the state of the expander dome and prevents the formation of folds resulting in reduced probability of pressure sores.

2. Fixing the valve dome of the expander when it is implanted with a needle prevents the dome from slipping back towards the main reservoir.

Enhanced Expander Implantation Technique at the border with a healthy skin with a scar, a 5–6 cm long incision was made. With the help of the corncang, a

channel and a bed for the valve tube are separately formed. Through a wide incision, the hemostasis of the area of the bed is visually performed. The expander is implanted. To prevent the valve tube from sliding backward, the latter is fixed subcutaneously with needles from the syringe. With the help of a spatula, the folds of the expander are leveled, at the base and the dome. The void space is drained by vacuum drainage. The wound is layer-by-layer closed with two-row sutures. Depending on the prevalence of the lesion, its localization and available stocks of stretched tissues, the methods of their usage were different.

Intraoperative rapid stretching of tissues $n = 35$ (46.1%). The width of cicatricial alopecia varied from 1.0 to 2.5 cm.

Technique of operation: A cut is made at the border of the cicatricial massif with healthy skin. Through this incision, a subcutaneous pocket is formed, corresponding to the size of the balloon.

The balloon is implanted in the formed bed.

The wound is temporarily sutured with nodal sutures. The balloon is intraoperatively filled with a maximum solution of furacillin, creating a compression on the tissue from the inside. After five minutes, the liquid is drawn back and relaxation of the stretched tissues occurs. After a three-minute interval, the balloon is again filled with liquid for 5 minutes.

This procedure is repeated three times. After this, taking into account the available amount of tissues, scars are excised and the wound formed is closed by intraoperatively stretched tissues

Results: In the near postoperative period, all 7 patients had no complications. In the long-term period (after 1.5–2 years), 6 (85.7%) of the 7 patients reported an expansion of the postoperative scar to 2–3 cm, which significantly reduced the functional and aesthetic results of operations.

In 1 (6.6%) patients after the final stage of plastic surgery, the necrosis of the distal end of the flap was observed in a traditional way. Subcutaneous hematoma occurred in 1 (6.6%) of the patient. In the long-term period, good results were recorded in 12 patients (80.2%) and satisfactory in 3 patients.

35 patients were operated in the main group of patients by the method of intraoperative rapid balloon dilatation. All 35 patients had no complications in the immediate postoperative period. In a remote period (1–1.5 years), 30 (85.7%) of 35 patients were examined. In 26 (88.7%)

patients, the results of operations were considered good, that is, their postoperative scars did not expand. Their width reached up to 2–3 mm, which greatly improved the functional and aesthetic results of the operation.

In one patient in the long-term period, because of divergence of the sutures, there was an increase in the postoperative scar.

As a result of improved expander plasty, there were no complications in the immediate postoperative period. In the long-term period, 1 (5.2%) patients had hair loss along the seam line. At the same time, good results were recorded in 18 (94.8%) patients and satisfactory results in 1 (5.2%) patients.

References:

1. Azolov V.V., Dmitriev G. I. Nizhny Novgorod School of Combustiology // Combustiology at the turn of the century: Intern. Kongress.– Moscow,– 2007.– P. 17–18.
2. Bogosian R. A., Vorobiev A. V. et al. The method of expander dermotension in the treatment of patients with thermal lesions of the soft tissues of the head and bones of the cranial vault // Mater. Intern. Conf. “Actual problems of thermal injury”, dedicated. 60th anniversary of the burn center of the Institute of First Aid to them. I. I. Djanelidze. June 20–22,– 2011.– St.-Petersburg,– 2011.– P. 225–226.
3. Krainik I. V., Anikin Yu. V. and others. Prospects and possibilities of the radiosurgical method in surgery and treatment of fired patients // Mater. Intern. Conf. “Actual problems of thermal injury”, dedicated. 70th anniversary of the Institute of First Aid to them. II Dzhanlidze and the 55th anniversary of the burn center. June 27–29.– 2008.– St.-Petersburg,– 2008.– P. 433–434.
4. Driscoll D. N., Levy A. N., Gama A. R. Dermabrasion and Thin Epidermal Grafting for Treatment of Large and Small Areas of Postburn Leukoderma: A Case Series and Review of the Literature // J. Burn Care Res.–2015.– Vol. 30.– No. 6.– P. 287–293.
5. Grishkevich V.M., Grishkevich M., Menzul V. Postburn neck anterior contracture treatment in children with scar-fascial local trapezoid flaps: a new approach // J. Burn Care Res.– 2015.– Vol. 36.– No. 3.– P. 112–9.

*Maksudova Dilnoza Yunusovna,
assistant, of Andizhan State
Medical Institute, Uzbekistan
E-mail: evovision@bk.ru*

DEMENTIA AS A GLOBAL PROBLEM OF XXI CENTURE

Abstract: Cognitive impairment in elderly patients with diabetes is an important medical and social problem. The article covers aspects of pathogenesis and treatment approaches of cognitive impairment and diabetes mellitus; in particular Actovegin as a treatment option for correction of cognitive status in diabetic patients.

Keywords: cognitive impairment, diabetes, elderly patients.

Recently on reception at doctors of various specialties, patients complain of memory violation. Even more often in diagnoses, it is possible to meet the formulation “cognitive violations”. However in the detailed analysis of these complaints and carrying out psychological testing it becomes clear that at many not memory, but attention suffers. In it there is nothing surprising as in our century of scientific and technical progress, excess amount of information, the Internet, mobile communication and by all means the stressful situations accompanying us it is very difficult to hold all information in the head. Therefore, all unnecessary, fulfilled very quickly passes into “depths” of long-term memory and over time is forgotten. Often the brain differentiates the arrived information on importance, rejecting all the rest. On the other hand, growth in the world of neurologic diseases leads to biochemical and structural violations of a cerebral cortex that first of all leads to mnestic violations. The global grow old age of the population is directly interfaced to a problem of quality of life at senior citizens. At advanced age, most often diagnose the vascular, primary, and degenerate diseases of a brain leading to cognitive disorders of varying severity: from moderated to the expressed.

Functional and anatomic researches of a brain testify that the associative zones of cerebral bark connected mainly with ensuring the highest brain functions considerably surpass primary motor and touch cortical fields in the area. Therefore natural is that fact that the majority of the neurologic diseases affecting the central nervous system is followed by violation of cognitive functions. Thus, cognitive frustration are the same fundamental neurologic symptom important for sindromal, topical and nosological diagnosis of diseases of nervous system,

as well as motive, sensitive and vegetative violations. Therefore, it is very important even to be able to reveal, prevent progressing on primary reception and to start treating these changes.

Research and medicamentous correction of the broken cognitive functions of a brain at patients with various neurologic diseases who showed complaints to decrease in memory and working capacity, the general weakness became the purpose of our work.

Three studied groups were allocated. 30 young patients who connected the symptoms with the postponed neuroinfection made the first; 20 patients with IC in the anamnesis entered the second; in the third – 28 people of 50–58 years with ischemic encephalopathy I – II stages against a hypertensive illness. Taking into account complaints we developed the scheme of testing which included research of the mental status (on MMSE scale), depressions (on Beck’s scale) and uneasiness (Spilbergera-Khanin’s scale), and also memory research (storing of 10 words, a visual memory, storing with an interference) and attention (proof test of Burdon, tests with Shulte’s tables).

In the analysis of the received results, it is revealed that all patients at primary inspection had a memory and the mental status within norm. At research of attention, decrease in indicators at 100% examined in all groups was noted. When carrying out proof test of Burdon violation of concentration and considerable violation of stability of attention was noted. Similar violations prevailed in group of patients with hypertensive ischemic encephalopathy and after the postponed craniocerebral injuries. Many patients because of fatigue refused to finish proof test.

The depression was revealed at all examined patients, and substantially – at 14% after the postponed IC, at 16% with vascular pathology and at 25% of patients after inflammatory diseases. Also uneasiness signs, in the prevailing majority – moderately expressed degree were found in all patients. We didn't observe reliable distinctions in all groups. And jet uneasiness (60% of patients) was moderate whereas personal (70%) it was estimated as high.

Thus, we noted absence the mnestichal of violations at the examined patients, despite existence of the corresponding complaints. Along with it we revealed objective signs of violation of other components of higher nervous activity – the emotional sphere and attention. Therefore our choice for correction of such violations fell on preparations, not only the improving informative functions of an organism, but also correcting the emotional sphere. 16 patients after the postponed neuroinfection and group of the patients having in the anamnesis of CCI accepted Tanacan in a dose 40 mg 3 times a day within 1 months. Other 14 people from group of an a neuroinfection and 21 patients with vascular disorders of a brain accepted fevarin in a dose 100 mg of 1 time a day, in the evening within a month.

After treatment testing which showed was held again that indicators improved in all groups of patients and had accurate correlation of patients and neurologic pathology with age. 60% of patients noted subjective improvement of memory, working capacity increase, improvement of quality of a dream. Reliable distinctions from the accepted treatment by us it wasn't noted. At all patients memory indicators that the mnestichal of processes under the influence of the carried-out treatment testifies to

activity improvement raised. In structure of testing the greatest improvement was noted in storing of 10 words, the smallest – in storing with an interference. Indicators of attention improved and entered norm limits on average at 75%. A little smaller results were observed in group of patients after the postponed CCI and with vascular pathology of a brain. Dynamics of uneasiness and a depression noted by us was one of the positive moments of treatment. Symptoms of a depression on Beck's scale after treatment were observed on average on groups at 10% of patients, and degree of their expressiveness decreased. Only one patient in group of vascular diseases had no improvement, and manifestations of a depression were estimated as high.

Considerable dynamics occurred and at an uneasiness assessment, and the greatest – at jet. On average it is revealed only at 50% of patients (before treatment – 100%).

Thus, we stated positive influence of preparations of nootropic action Tanacan and Fevarin on dynamics of cognitive and psycho emotional functions at patients after the postponed inflammatory diseases and injuries of a brain, and also at hypertensive encephalopathy. The revealed data allow to assume that complaints of patients of these groups to decrease in memory are connected with existence of a depression that leads to absent-mindedness and instability of attention. Antidepressants and anti-disturbing action of these preparations caused subjective improvement of a condition of patients. Besides, we noted increase of indicators of memory, which before treatment were in norm limits that, is caused by nootropic action of the appointed preparations.

References:

1. Artemyev D. V., Zakharov V. V., Levin O. S., Preobrazhenskiy I. S., Yakhno N. N. Aging and neurodegenerate frustration: cognitive and motive violations at advanced age // – M., – 2005.
2. Bachinskaya N. Yu. Sindr of soft cognitive decrease at senior citizens // the AMN Magazine of Ukraine. – 2004. – T. 10. – No. 3. – P. 552–562.
3. Bachinsky N. Yu. Intellektualno-mnesticheskaya activity and personal features during the aging and vozrastzavimsy pathology of a brain: Avtoref. yew... d.m.n:14.01.05 – nervous diseases. – Kiev. – 2005.
4. Damulin I. V. Easy cognitive violations. Consilium medicum, – 2004. – T. 6. – No. 2. – P. 149–153.
5. Damulin I. V. Cognitive violations of vascular genesis: clinical and therapeutic aspects // Difficult Patient Magazine. – No. 7. – 2006.
6. Zakharov V. V., Yakhno N. N. Memory violations. – M.: Geotarmed. – 2003. – 150 p.
7. Mankovsky N. B., Bachinskaya N. Yu., Poletayeva K. N. Sindr of moderate cognitive violations at senior citizens // the Ukrainian neurologic magazine Is well-cared. – 2006. – No. 1. – P. 47–53.

8. Trinitatsky Yu.V., Lemeshevskaya A. A. Cognitive violations at patients with multiple sclerosis and their correction // *Clinical neurology*.– 2007.– No. 2.– P. 27–30.
9. Yakhno N. N., Zakharov V. V. Easy cognitive frustration at advanced age // *Neurologic magazine*. – 2004.– T. 9.– No. 1.– P. 4–8.
10. Yakhno N. N., Zakharov V. V. Cognitive and emotional and affective violations at distsirkulyatorny encephalopathy // *Russian medical magazine*.– 2002.– T. 10.– No. 12–13.– P. 539–542.

*Makhmudova Zulfiya Primkulova,
senior researcher, Republican Specialized Scientific
Practical Medical Center Phthysiology and Pulmonology
E-mail: evovision@bk.ru*

THE ROLE OF PROINFLAMMATORY CYTOKINES IN THE PATHOGENESIS OF TUBERCULOSIS

Abstract: Foci of inflammation, formed during TB, include a whole cascade of metabolic reactions on the part of the body aimed at limiting the focus of inflammation and restoring local homeostasis. As a result of the inflammatory reaction around the focus of inflammation, synthesis of acute phase proteins predominates, the level of which is regulated by various inducers. Such inducers include proinflammatory cytokines, primarily IL-1 β and tumor necrosis factor, which are synthesized by various cells surrounding the ischemic focus – fibroblasts, vascular endothelium, activated macrophages and T-lymphocytes. At a high concentration, IL-1 β becomes a mediator of tissue damage, triggers a mechanism of increased production of TNF- α , which in turn has a damaging effect on body tissues.

Keywords: Cytokines, pathogenesis, primarily, tuberculosis.

In the pathogenesis of TB, cytokines play a significant role. Cytokines regulate the development of local protective reactions of the body in tissues involving various types of blood cells, endothelium, connective tissue and epithelium [1, 3]. TNF- α is a pro-inflammatory cytokine produced by various cells, including activated T cells, keratinocytes and Langerhans cells. TNF- α has multiple effects in the development of an immune response, triggering activation and a set of inflammatory cells, increasing the production of pro-inflammatory cytokines IL-1, IL-6 and IL-8, and activating nuclear transcription factors such as NF-KB to maintain an immune response. At TB, elevated levels of TNF- α and TNF- α receptor expression are noted. TNF- α induces the maturation of Langerhans cells, also stimulates the migration of mature Langerhans cells from the skin to the lymph nodes where the interaction between antigen-presenting cells and T cells occurs. TNF- α increases the proliferation of keratinocytes in vitro. It is suggested that TNF- α blocks apoptosis of keratinocytes and contributes to a longer lifetime of keratinocytes in the skin of patients with TB. TNF- α affects the vascularization of the skin and promotes increased expression of endothelial adhesion molecules involved in the migration of T cells. In addition, TNF- α increases the production of vascular endothelial growth factor (VEGF), which leads to vascular proliferation [5].

Purpose of the study. Study of pathogenetic mechanisms of development of tuberculous spondylitis in patients with lung involvement.

Material and methods. The study was based on a clinical laboratory examination of 100 patients with various forms of pulmonary tuberculosis, of which 45 patients with pulmonary tuberculosis combined with tuberculosis spondylitis who were hospitalized in the pulmonary tuberculosis and osteoarticular tuberculosis departments of the Republican Specialized Scientific and Practical Medical Center of Phthysiology and Pulmonology of the Ministry of Health of the Republic of Uzbekistan, of comparable age in the period from 2014 to 2016.

The level of proinflammatory cytokines was determined by the method of enzyme immunoassay

Results and its discussion. The main role in the pathogenesis of spondylitis in patients with TB is given to T cells, especially CDS + cells, which promote increased production of cytokines, including IL-1, IL-2, IL-10, TNF- α , in synovial fluids in patients with AB. These cytokines induce the proliferation and activation of synovial and epidermal fibroblasts, leading to the formation of fibrosis in patients with long-standing arthritis. TNF- α is associated with bone and cartilage destruction in arthritis. The pro-inflammatory cytokines IL-1 β and TNF- α also play an important role in

bone metabolism by increasing the osteoclastogenesis through up-regulation of osteoprotegerin ligand (OPGL), a new molecule that is a receptor of TNF- α expressed by activated T cells. Erosive changes are as-

sociated with elevated levels of osteoclast precursors in peripheral blood.

Thus, TNF- α and IL-1 β play a key role among inflammatory mediators in the pathogenesis of TB (Table 1).

Table 1. – Indicators of IL-1 β and TNF- α in tuberculosis

Indicators	Control group (n = 30)	Comparison group (n = 55)	The main group (n = 45)
IL-1 β $\mu\text{g}/\text{ml}$	35.3 \pm 0.5	157. \pm 80.7***	199.1 \pm 1.4***^^^
TNF- α , $\mu\text{g}/\text{ml}$	3.73 \pm 0.91	4.77 \pm 0.73	7.26 \pm 0.89***^

Note: * – the differences with respect to the control group are significant (** – $P < 0.01$, *** – $P < 0.001$), the D-differences with respect to the data of group 1 are significant (^ – $P < 0.05$, ^^ – $P < 0.001$)

Interleukin-1 β increased to 157.8 pg/ml, which is an increase in the level of 4.4 times with the surface form and up to 199.1 pg/ml – in 5.6 times in the patients of the main group compared with the control group. The tumor necrosis factor (TNF- α) with the surface form of AB increased by 1.28 times, and in patients of the main group – by 1.94 times. Obviously, there is a clear tendency to increase the value of cytokine indices during the process chronicization.

Inflammation develops in response to damage and penetration into the tissue of pathogens with the participation of pro-inflammatory cytokines. These cytokines are synthesized in the inflammatory focus by macrophage cells. They cause activation of the endothelium, leading to increased permeability, increased expression of adhesion molecules and increased procoagulant activity. There is an outburst of low-molecular inflammatory mediators, such as histamine, prostaglandins. Simultaneously, proinflammatory cytokines activate the metabolism of connective tissue, stimulate the proliferation of fibroblasts and epithelial cells, which is important for healing the damage and restoring tissue integrity.

Foci of inflammation, formed during TB, include a whole cascade of metabolic reactions on the part of the body aimed at limiting the focus of inflammation and restoring local homeostasis. As a result of the inflammatory reaction around the focus of inflammation, synthesis of acute phase proteins predominates, the level of which is regulated by various inducers. Such inducers include proinflammatory cytokines, primarily IL-1 β and tumor necrosis factor, which are synthesized by various cells surrounding the ischemic focus – fibroblasts, vascular endothelium, activated macrophages and T-lymphocytes. At a high concentration, IL-1 β becomes a mediator of

tissue damage, triggers a mechanism of increased production of TNF- α , which in turn has a damaging effect on body tissues.

In clinical practice, immunological studies in patients with tuberculosis are used for the purpose of not only diagnosing and elucidating the state of the patient's immune system, but may also be important for determining the prognosis of the course of the disease, detecting a possible relapse. Of particular importance is the analysis of nonspecific and specific indicators, the duration of significant disturbances, and their comparison with: clinical and radiological symptomatology of the process. Long-term preservation of T-cell deficiency, high levels of auto- and anti-tuberculosis antibodies, absent or decreased response of lymphocytes to tuberculin is characteristic of the progressive course of tuberculosis. The presence of these signs at early stages of observation should be the basis for the inclusion of pathogenetic agents in the comprehensive therapy of tuberculosis.

Immunological studies can be used to determine the effectiveness of treatment and the completeness of recovery of patients. Comparing the nature of disorders in the immune system to treatment, during and after therapy, it is possible to identify a certain dynamics of changes. In most cases, with effective therapy, there is an improvement in immunological parameters, and in some patients – their normalization. However, clinical recovery usually outstrips the normalization of the immune status.

Conclusion. At a high concentration, IL-1 β becomes a mediator of tissue damage, triggers a mechanism of increased production of TNF- α , which in turn has a damaging effect on body tissues.

References:

1. Bellendir E. N. Peculiarities of immunopathogenesis of extrapulmonary tuberculosis of various localizations according to experimental and clinical studies, Extrapulmonary tuberculosis is an urgent public health problem: Sb. All-Russia scientific-practical conference.– St.-Petersburg,– 1997.– 25 p.
2. Vatutina V. V., Kovalenko K. N. Tuberculosis of respiratory organs in osteoarticular tuberculosis in young children // Problems of tuberculosis.– 2003.– No. 3.– P. 31–33.
3. Garbuz A. E. The condition and prospects of development of surgery of bones, joints and spine in adults // Problems of tuberculosis.– 2001.– No. 4.– P. 57–58.
4. Oleinik V. V. The tumor necrosis factor in the pathogenesis of spinal cord function recovery in spinal tuberculosis // Problems of tuberculosis.– 2003.– No. 5.– P. 26–28.
5. Cytokine profile in patients with spinal tuberculosis / V. M. Ivanov, V. N. Guseva, R. I. Shenderova, N. S. Novikova, E. A. Lipskaya, A. E. Garbuz // VII Russian Congress of Phthisiatricians.– 125 c.

*Murtazaev Saidazim Saidagzamovich,
Ph.D., Tashkent State dental institute
senior lecturer, of Prosthodontics and Orthodontics department
E-mail: dr.saidazim@mail.ru*

*Nasimov Elbek Elhonovich,
assistant, of Prosthodontics and Orthodontics department
Tashkent State dental institute
E-mail: dr.nasimov@gmail.com*

*Voidov Giyos Gulom ugli,
student, of the faculty of dentistry
Tashkent State dental institute
E-mail: giyosvokhidov@mail.ru*

*Aminov Elmurod Komiljonovich,
student, of the faculty of dentistry
Tashkent State dental institute
E-mail: Aminove@gmail.com*

*Murtazaev Saidmurodkhon Saidaloevich,
DMD, Tashkent State dental institute
Head of Pediatric dentistry department
E-mail: Saidmurodtma@mail.ru*

COMPARISON OF THE RESULTS OF SUPERIMPOSITION AS WELL AS MANUAL AND COMPUTER SOFTWARE OF CEPHALOMETRIC IMAGERY

Abstract: 43 pairs of cephalograms were analyzed after pretreatment (T1) and after treatment (T2), 21 men of 22 women. the average value of T2 LD for manual and digital overlays is not zero. However, the differences were small (<1 mm) and could be considered clinically insignificant. Thus, the digital imposition method can accurately duplicate and replace the traditional imposition method for both the cranial base and regional overlays.

Keywords: Computer program, manual tracing, cephalometric analysis.

Introduction. Practitioner orthodontists switch to paperless offices and obtain digital records. This transition was partly due to advances in the field of new technologies, which led to the creation of advanced tubeless cephalometric radiology equipment. Digital radiology has several advantages over X-ray film-based systems. The imposition of cephalometric radiographs on specific anatomical structures is a method used by clinicians to visualize changes in growth and effects of orthodontic treatment on the jaws and teeth.

As a basic measure for clinical orthodontic studies, regular use is made of superimposition – the imposition. Considering the importance of cephalometric an-

alogs and superimpositions for orthodontic diagnosis, the accuracy of computer tracking software should be established by comparing them with manual trace on acetate paper based on the gold standard. There are no differences in the definition of cephalometric reference points on traditional films or on digital cephalometric radiographs. With the help of cephalometric analysis using the most popular computer programs it is possible to create linear and angular measurements, as in manual measurement. However, only a few studies have examined cephalometric superimpositions created by these programs. We did not find any information about using a special oriented function for creating digital

settings in V-ceph. As digital radiography becomes more common, manual superimpositions become less attractive. However, many of the problems that exist in the current digital software and they are not controlled by the operator. The purpose of this study was to determine the ability of the operator to produce comparable superimpositions using digital V-ceph and manual methods (gold standard), and to assess the differences between digital imposition of cranium bases and digital SN imposition techniques.

Materials and methods

All patients received complex orthodontic treatment, only radiographs of excellent quality were selected.

– 43 pairs of radiographs were selected after pretreatment (T1) and after treatment (T2). X-ray photographs of 22 women and 21 men were used.

Traditional cephalometric reference points (Table 1) were identified on all radiographs using a 0.5 mm pencil. The orthogonal axis was drawn with a pencil on T1 films. Radiographs are scanned and installed into the V-ceph software. Orthogonal axes served to determine the location of reference points between the methods of superimposition for the same object. For the superposition of cranial bases, the horizontal axis was drawn through the Sella-Nasion with the vertical axis through Sella (Figure 1).

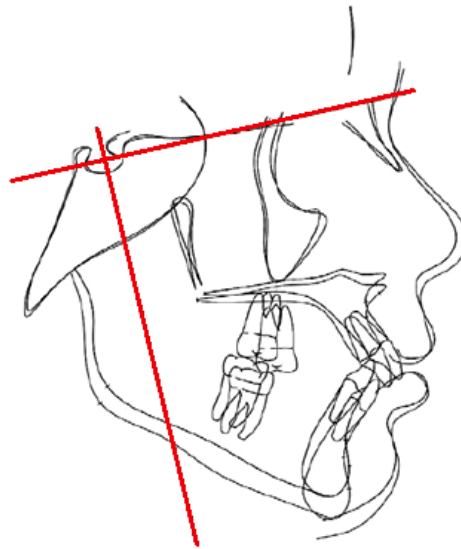

Figure 1. The horizontal axis is drawn through the Sella-Nasion points and the vertical axis through Sella

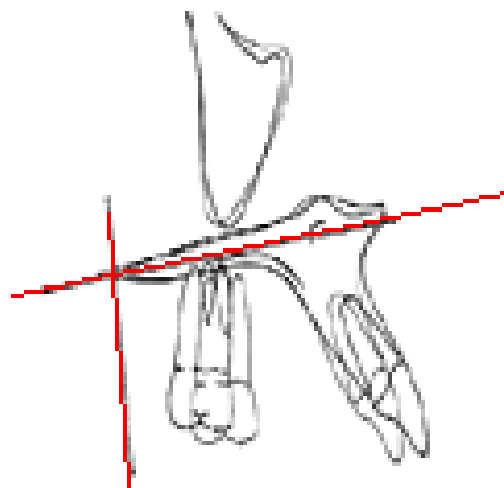

Figure 2. In the maxillary region, the horizontal axis was drawn through the anterior nasal-SNA and posterior nasal-SNP

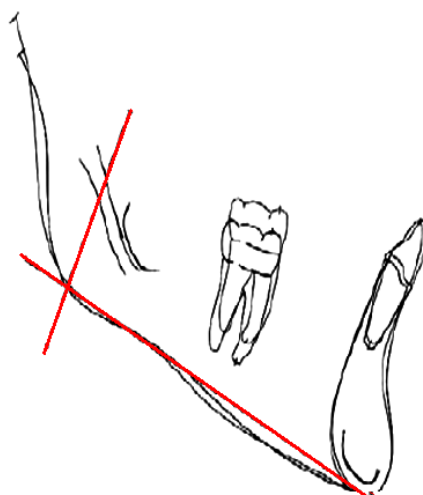

Figure 3. The horizontal axis was drawn through the front point – Menton and the back point – Gonion

In the maxillary region, the horizontal axis was drawn through the anterior nasal-SNA and posterior nasal-SNP and the vertical axis through the posterior nasal-SNP (Figure 2).

On the lower jaw, the horizontal axis was drawn through the front point – Menton and the back point – Gonion with a vertical axis through the Gonion (Figure 3).

Each X-ray image was calculated using a manual, digital method and standard cephalometric measurements (SN-FH, SN-MP, SNA, SNB, ANB, U1-SN, L1-MP). Manual drawing was done on acetate paper in a darkened room on a negatoscope. Trace T1 on acetate with superimposition on the film X-ray film using a mechanical pencil with a diameter of 0.3. This trace best suited directly to the T2-X-ray, then depicted in red on the same acetate. Digital superimpositions were completed using V-ceph. All the standard anatomical structures were outlined using software. The peeling was carried out independently of each other. The cranial plane was held on the front of the sella turcica and the inner contour of the frontal bone. Maxillary superimposition is performed along the lower border of the sky and the inner cortical layer of the upper jaw. Mandibular superimposition was performed along the inner contour of the mandibular symphysis.

For the manual and digital method, identical layering methods were used. For the digital method, the function of imposing specially prepared anatomically repeating template structures was applied. Digital cranial base superimpositions are specially prepared anatomically re-

petitive template structures embedded in the software. T2 to trace T1 anywhere.

Using the methods described earlier, digital superimpositions based on the best matching of the skull were compared to the digital overlay S-N. In 3 of the 43 x-ray diffraction patterns, the difference between the manual and digital best-placed cranial superimposition was greater (> 1 mm). Thus, 40 X-ray images of patients with a treatment period from 6 months to 5.5 years were collected. These X-rays were divided into three groups, depending on the duration of the period T1-T2. Group 1 is patients with a treatment period of 0–2 years, in the second group of patients with a treatment period of 2–3 years, in the third group of patients with a treatment period of more than 3 years.

Discussion

The principal novelty of our study is that the average value of T2 LD for manual and digital superimpositions is not zero. However, the differences were small (< 1 mm) and could be considered clinically insignificant. Thus, the digital imposition method can accurately duplicate and replace the traditional imposition method for both the cranial base and regional superimpositions. When comparing manual and digital superimpositions, the upper limit of 95% confidence in the mean was less than 1 mm for all variables, except for the tip and root (1.09 mm).

In order to prevent the error of identifying the reference point between the manual and digital samples, all the reference points were identified on the original

radiographs from which the manual and digital tracing were created and, thus, this source of errors was significantly reduced or eliminated. Another source of error will be related to superimposition. Data on the range of errors of the cranial base and regional overlap in the literature vary. The method errors found in this study are analogous to the errors found in the literature for the reproducibility of superimpositions. However, it is difficult to quantitatively compare examples of imposition errors due to the many different methods used to calculate and describe errors. Few studies have reported the accuracy of digital superimpositions. The results of the other two studies coincide with the data obtained by us that the digital superimpositions created by computer programs are similar to those obtained manually.

Conclusion

1. There are no differences between the cranial base and the regional superimpositions obtained by V-ceph and the method performed by hand.

2. Given that the differences were within the measurement error, accurate interpretation of the growth and changes resulting from orthodontic treatment is possible.

3. There is some difference in the clinical consistency between the best-placed cranial base and the superposition of S-N. However, since treatment time is longer than 3 years in growing patients, the application of S-N can provide a less accurate idea of growth.

4. This study provides support for the transition from manual to digital superimposition methods.

References:

1. Арсеньева А. В., Трезубов В. Н., Фабеев Р. А., Особенности получение прямых телерентгенограмм головы для их качественной оценки // Матер. IX Междунар. Конф. Челюстно-лицевых хирургов и стоматологов. СПб., – 25–27 мая. – 2004. – 24 с.
2. Хорошилкина Ф. Я. Новые возможности определения функциональных нарушений в зубо- челюстно-лицевой области на основании изучения телерентгенограмм головы // Матер. VIII Междунар. конф. челюстно-лицевых хирургов и стоматологов. – СПб., – 2003. – С. 175–176.
3. Хорошилкина Ф. Я. Рентгенологические исследования в ортодонтии: дополнительные возможности улучшения качества диагностики и лечения // Стоматология для всех. – 1999. – № 2–3. – С. 44–46.
4. Хорошилкина Ф. Я. Ортодонтия. – М.: Медицина, – 2006. – 541 с.
5. Хорошилкина Ф. Я., Малыгин Ю. М., Биллинг В. А. и др. Сравнительный телерентгенологический анализ строения лицевого скелета в период сменного и постоянного прикуса в норме // Науч. тр. Центр, ин-та усоверш. врачей. – М., – 1989. – Т. 228. – С. 121–125.
6. Keim R. G., Gottlieb E. L., Nelson A. H., Vogels D. S. JCO orthodontic practice study. part 1: trends. J Clin Orthod. – 2005. – 39. – P. 641–650.
7. Chen Y. J., Chen S. K., Yao J. C. C., Chamg H. F. The effects of differences in landmark identification on the cephalometric measurements in traditional versus digitized cephalometry. Angle Orthod. – 2004. – 74. – P. 155–161.
8. Mc Clure S. R., Sadowaky P. L., Ferreira A., Jacobson A. Reliability of digital versus conventional cephalometric radiology: a comparative evaluation of landmark identification error. Semin Orthod. – 2005. – 11. – P. 98–110.
9. Ongkosuwito E. M., Katsaros C., van't Hof M. A., Bodegom J. C., Kuijpers-Jagtman A. M. The reproducibility of cephalometric measurements: a comparison of analogue and digital methods. Eur J Orthod. – 2002. – 24. – P. 655–665.
10. Dana J. M., Goldstein M., Burch J. G., Hardigan P. C. Comparative study of manual and computerized cephalometric analyses. J Clin Orthod. – 2004. – 5. – P. 293–296.
11. Gutierrez A. Accuracy of Cephalometric Analysis Using Imaging Software versus Conventional Hand Tracing [thesis]. Bronx, NY: Saint Barnabas Hospital; – 2006.
12. Roden-Johnson D. D. Comparison of Hand-traced and Computerized Cephalograms: Landmark Identification, Measurement and Superimposition Accuracy [thesis]. Houston: The University of Texas Health Science Center at Houston; – 2006.
13. Bruntz L. Q., Plomo J. M., Baden S., Hans M. G. A comparison of scanned lateral cephalograms with corresponding original radiographs. Am J Orthod Dentofacial Orthop. – 2006. – 130. – P. 340–348.

14. Santoro M., Jarjoura K., Cangialosi T.J. Accuracy of digital and analogue cephalometric measurements assessed with the sandwich technique. *Am J Orthod Dentofacial Orthop.*– 2006.– 129.– P. 345–351.
15. Melsen B. The cranial base. *Acta Odontol Scand.*– 1974.– 32(suppl 62).– P. 9–111.

*Niyazov Shukhrat Tashmirovich,
assistant professor, of the Department
of Neurology and Neurosurgery Ph D,
Samarkand State Medical Institute
E-mail: shucrat@mail.ru*

*Djurabekova Aziza Takhirovna,
Chief of the Department of Neurology and Neurosurgery, Ph D.,
Samarkand State Medical Institute professor,
E-mail: shucrat@mail.ru*

*Igamova Saodat Sur'atovna,
assistant professor,
of the Department of Neurology and Neurosurgery
Samarkand State Medical Institute
E-mail: saodat_igamova@mail.ru*

MORPHOLOGICAL STUDY OF RAT BRAIN IN THE EXPERIMENT WITH CHRONIC ENCEPHALITIS UNDER THE ACTION OF OZONIZED NEUROPROTECTORS

Abstract: The actual at the present stage in neurology is the study and rehabilitation of the long-term effects of central nervous system damage in children (encephalitis, myelitis, encephalomyelitis) which often lead to disability of patients. The actual at the present stage in neurology is the study and rehabilitation of the long-term effects of central nervous system damage in children (encephalitis, myelitis, encephalomyelitis) which often lead to disability of patients.

Keywords: encephalitis, myelitis, encephalomyelitis, Cerebrolysin, neuroprotector, ozone, glial cell, microcirculation, pathogenetic therapy.

Introduction. The actual at the present stage in neurology is the study and rehabilitation of the long-term effects of central nervous system damage in children (encephalitis, myelitis, encephalomyelitis) which often lead to disability of patients. The actual at the present stage in neurology is the study and rehabilitation of the long-term effects of central nervous system damage in children (encephalitis, myelitis, encephalomyelitis) which often lead to disability of patients. Cerebrolysin has a predominantly neuroprotective effect.

Cerebrolysin contains low molecular weight biologically active neuropeptides that penetrate the BBB and directly enter the nerve cells. The drug has an organ-specific multimodal effect on the brain, i.e. provides metabolic regulation, neuroprotection, functional neuromodulation and neurotrophic activity. Experiments in animals have demonstrated that cerebrolysin has a direct effect

on neuronal and synaptic plasticity, which contributes to the improvement of cognitive functions. Cerebrolysin can significantly slow down, and in some cases also stop the progression of neurodegenerative processes.

Various aspects of the properties of cerebrolysin, including the state of the membrane fraction, vitamin activity, amino acid, trace element and peptide compositions were studied in detail. The analysis of the drug made it possible to establish the presence of active peptide fragments of the nerve growth factor (NGF) and a number of neurotrophic peptides that stimulate the regeneration of neurons, axon growth, and other aspects of the functioning of neurons. It is shown that its composition includes neuropeptides, which are biologically active fragments of growth factors of the nervous tissue. The light peptide fraction of cerebrolysin (up to 1500 Da) contains active fragments of NGF, enkephalin,

tyroliberin, orexin and galanin. An analysis of their molecular pharmacological action has shown the promise of researching synergistic effects between neuroactive peptides of cerebrolysin and neuroactive micronutrients. The authors indicate that in some cases (anemia and other hypoxic conditions in the blood), there is no final separation of cerebrolysine into amino acids in the peptide fractions. As a consequence, in their opinion, there is no complete neurotrophic efficacy of cerebrolysin. However, there is insufficient information in the literature on the effect of ozonized neuroprotectors on the central nervous system.

The literature provides information on a number of positive properties of ozone: bactericidal, viricidal (antiviral) and fungicidal (antifungal) actions, immunomodulation (small doses stimulate immunity, large-suppress), influence on oxygen budget and metabolism, systemic restoration of homeostasis, restoration of oxygen transport function of blood, optimization of pro and antioxidant systems, restoration of microcirculation and peripheral circulation, optimization of homeostasis, stimulation of hematopoiesis, activation of doses of biologically active substances, optimization of the metabolism of biological substrates of carbohydrates, proteins, lipids (bioenergetic, biosynthetic effects), analgesic, anti-inflammatory, detoxification, fibrolytic action.

In these cases, the introduction of ozonized cerebrolysin makes it possible to achieve its separation into enkephalins, tyroliberin, orexin and galanin. And to mean to achieve high-grade neurotrophic efficacy of the drug.

There are opinions that the introduction of three atomic oxygen, that is, ozone, favorably affects the architectonics of brain structures and prevents the severe irreversible consequences of hypoxic encephalopathy. However, morphological parameters in the structures of the brain in animals and humans have not been studied so far, under the influence of the ozonized neuroprotector in a comparative aspect with the effect of the nonozonized neuroprotector.

The structural elements of the brain are very sensitive to hypoxia. Hypoxic encephalopathies developing for various reasons, are accompanied by various changes, the degree of which depends on the severity of hypoxia and the causes of their causes.

The purpose of this work: to compare the morphological data of the action of neuroprotectors and ozon-

ized neuroprotectors on the structures of the rat brain in chronic encephalitis.

Materials and methods of research. Studies were carried out on 50 white mongrel rats with a weight of 180–240 grams. The animals were divided into the following groups: I-control group-10 rats. II-30 rats with residual phenomena of the encephalitis transferred and received traditional treatment, including with cerebrolysin. They were divided into 3 subgroups: II-A-im injected 0.02 ml of cerebrolysin, II-B-im introduced 0.05 ml of cerebrolysine and II-B-he was administered 0.1 ml of cerebrolysin. III-10 rats with residual phenomena of the encephalitis transferred and received in addition to traditional treatment ozonized cerebrolysin in a dose of 0.02 ml.

Histological preparations, that is, sections of the brain are colored with hemotoxylin-eosin.

Discussion of the study results:

Morphological changes in the brain in rats not exposed to ozonized effects.

In II-A, the experimental group was treated at different times from the onset of the disease. The treatment was conducted for 20 days, this period is justified by the fact that during this time the therapeutic effect of the drug was achieved. During this period, against the background of positive clinical dynamics, the morphological picture also showed positive changes: the sizes of perivascular and pericellular edema of the nervous tissue decreased. In the vasculature there is a slight widening of the lumen of the blood vessels. The walls of the ventricles of the brain are expelled by single-row epithelium and the vessels in the ventricular wall are asleep, empty.

In the subependymary zones of the brain tissue, focal proliferation of astrocytes of compensatory nature was noted (Fig. 1).

In the experimental group II-B, the following morphological pattern is revealed microscopically in the brain tissues: small, vascular and perivascular cell infiltrates of the vascular-connective tissue apparatus of hematogenous and local origin are found in the cortex and glia of the brain. In the glia there are areas, both with loosening, and with insignificant in intensity proliferative processes, which leads to the formation of small adhesions. Diminishes the size of the pericellular edema of the nervous tissue. In the vasculature there is a slight widening of the lumen of the blood vessels. The lumen of some blood vessels is closed with shaped

elements of blood. There are vessels in which the desquamation of the endothelium of the wall sections is observed. Small hemorrhages are detected in the areas of the cortex and glia adjacent to the membranes of the brain. Mononuclear-macrophagal microglial cells

are detected. The nucleus of individual cells is larger than other cells, in places foamy macrophagous bodies are found.

The proliferative processes on the part of the glia are heterogeneous (Fig. 2).

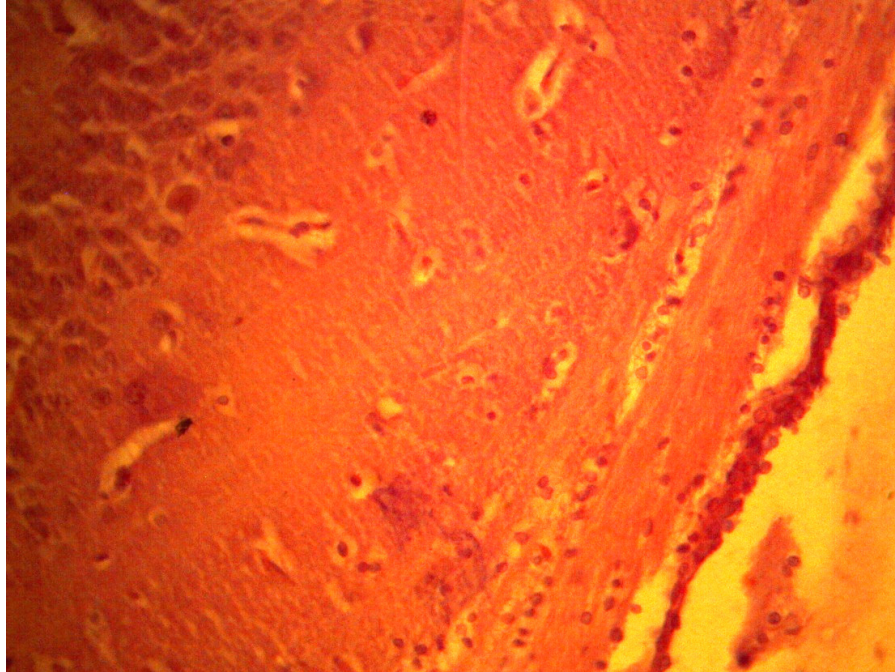

Figure 1. On the 10th day from the beginning of treatment. The ependyma of the lateral ventricles is strongly edematous, the ependymocytes are exfoliated, desquamated. Pericellular swelling is sharply expressed. Color: hematoxylin eosin. X: (magnification – 200 times)

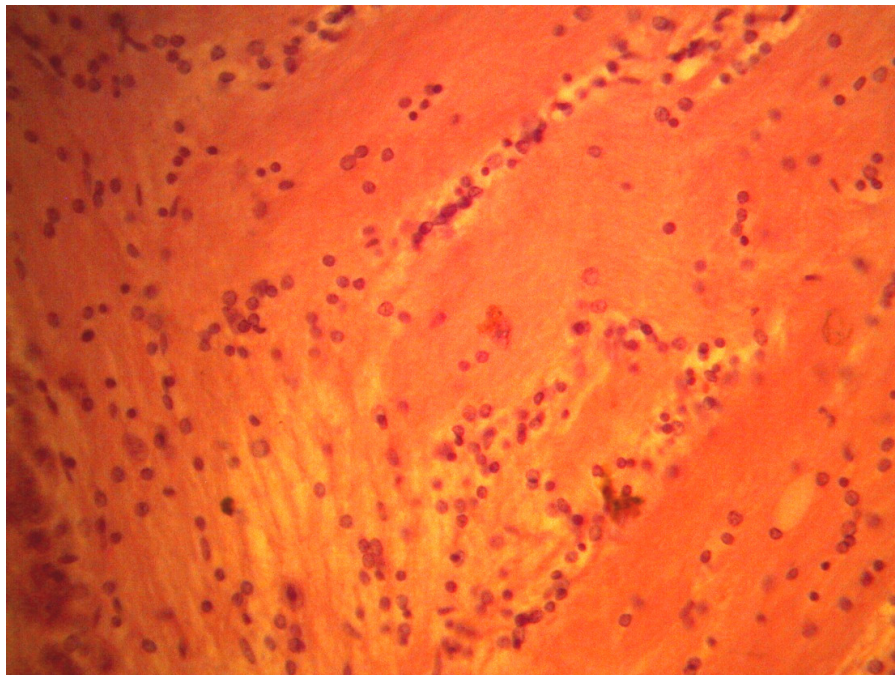

Figure 2. On the 10th day from the beginning of treatment. Many microglial macrophage cells. In some cells, the appearance of foamy bodies in the cytoplasm. Color: hematoxylin eosin

In group II-B, the edematous loosening of the brain substance is observed microscopically, expressed mainly

by perivascular edema. Most intracerebral vessels gap, that is, ischemic (Fig. 3).

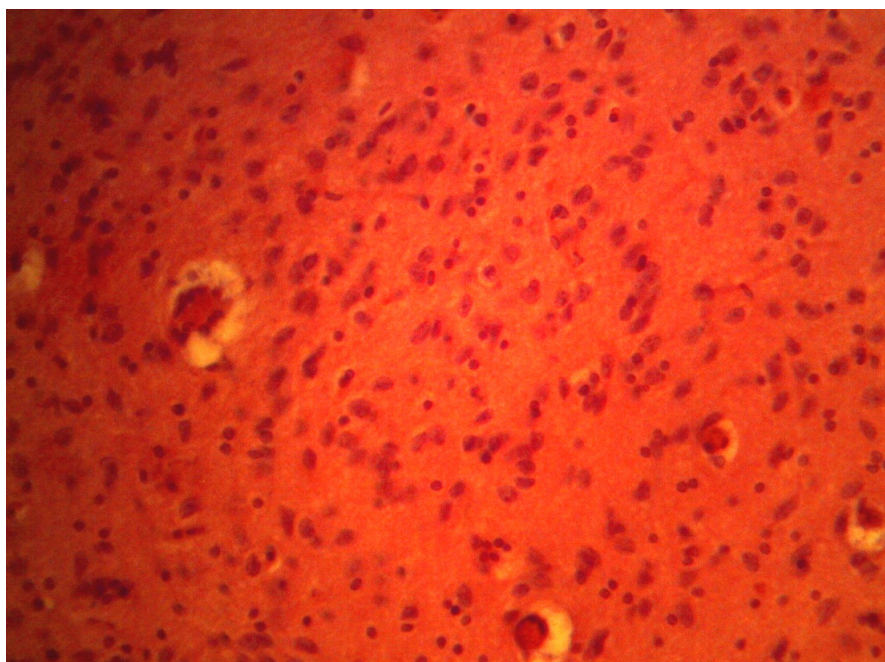

Figure 3. At 15 days from the start of treatment. There is a pronounced ischemia in the vessels of the brain. There is an increase in the size of the cytoplasm due to edema, the appearance of nucleoli. Color: hematoxylin eosin

The cytoplasm of the oocytes is enlarged in volume, the nuclei are hypertrophied, nucleoli sometimes appeared. Sciatica are elongated and eosinophilic. In some places one

can see cells with neuronophagia, which is a sign of physiological regeneration and apoptosis (Figure 4).

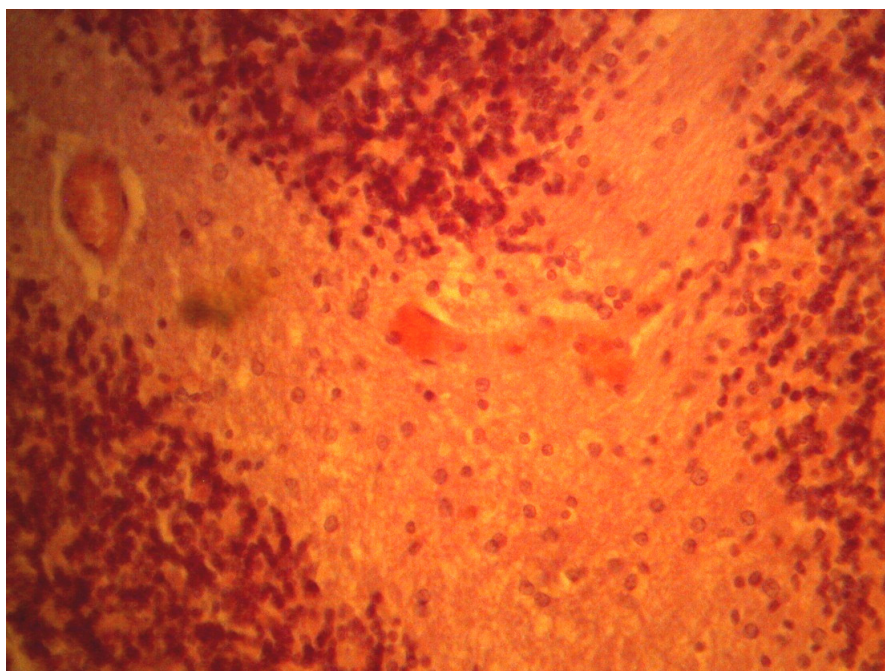

Figure 4. On the 20th day from the beginning of treatment. A significant loosening and dilution of rat brain tissue. The pericellular edema is more pronounced. Color: hematoxylin eosin. X: ok.10, o6.20

Thus, against the background of traditional therapy with the use of a large dose of cerebrolysin in the morphological picture against the background of the restoration of neurons appear ischemic foci. This in turn, in our opinion, can provoke the death of neurons around the ischemic focus, and reduces the expected clinical effect.

Morphological changes in the brain in rats exposed to ozonized cerebrolysin..

In the third experimental group, 0.02 ml of ozonized cerebrolysin was intravenously injected to determine the best neuroprotective effect.

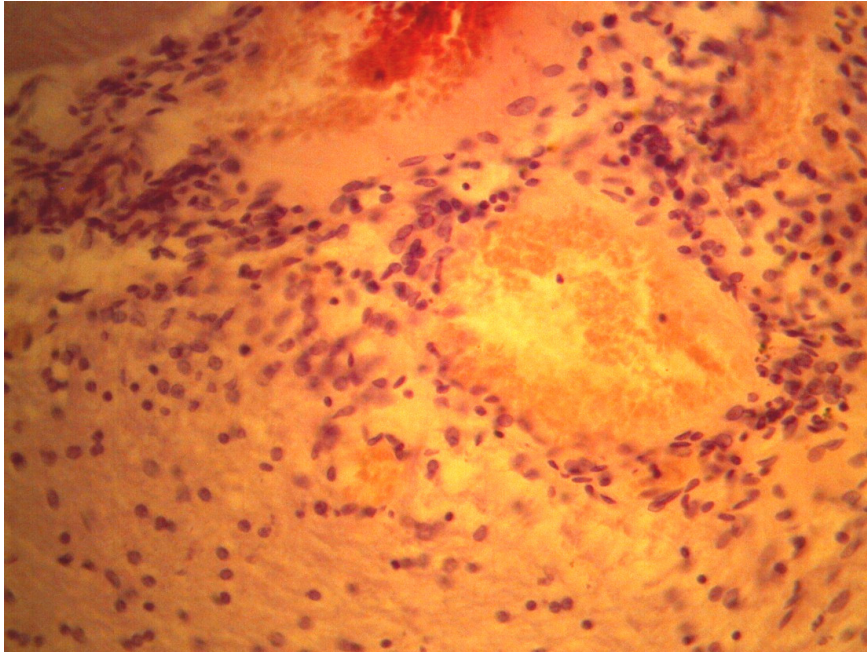

Figure 5. At 10th days from the beginning of treatment. There is a blood filling of cerebral vessels, macrophage-mononuclear cells and some edema of brain tissue are visible. Color: hematoxylin eosin. X: ok.10, o6.20

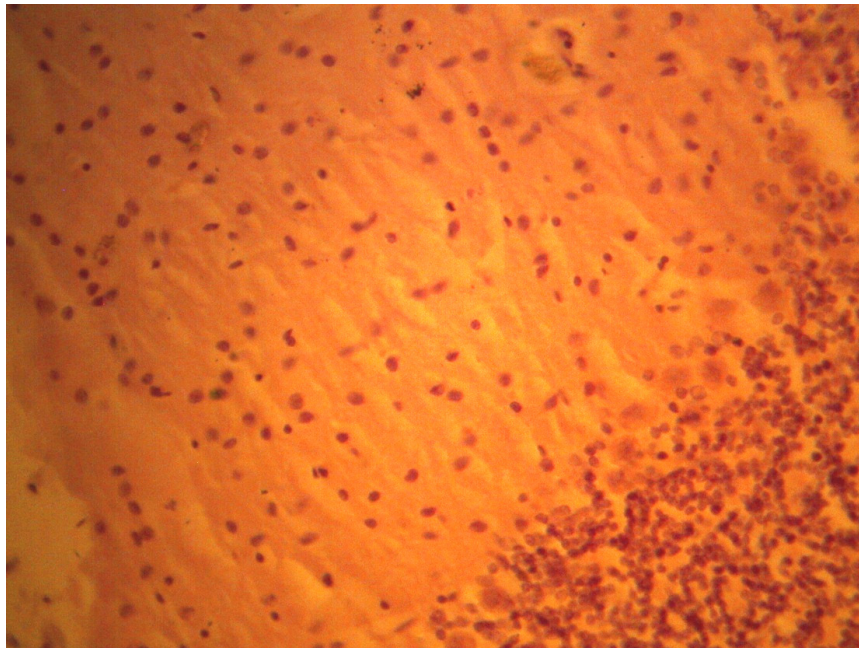

Figure 6. At 10th days from the beginning of treatment. Moderate rarefaction and easy loosening of the intercellular stroma of the brain. Color: hematoxylin eosin. X: ok.10, o6.20

Clinical observation of experimental animals showed that in animals of Group III, neuronal defect recovery was earlier performed (the rats became active and the paralysis of the extremities decreased significantly faster, the reflexes of self-defense were more pronounced than in the subgroups of the II experimental group).

On the 10th day of the introduction of ozonized cerebrolysin in the vessels of ependyma, even fullness is observed. The dimensions of the cytoplasm of the islets are the same everywhere, not where the nucleoli

are not detected. Scions of astrocytes everywhere the same size. Mononuclear-phagocytic macrophages are rare (Fig. 5).

Swelling loosening is less pronounced and affects only individual vessels of the brain (Fig. 6).

On the 15th day of treatment with ozonized cerebrolysin, pericellular edema is slightly pronounced. The degree of blood-filling of brain pockets in these rats is better compared to the 10 days of ozonized cerebrolysin (Fig. 7).

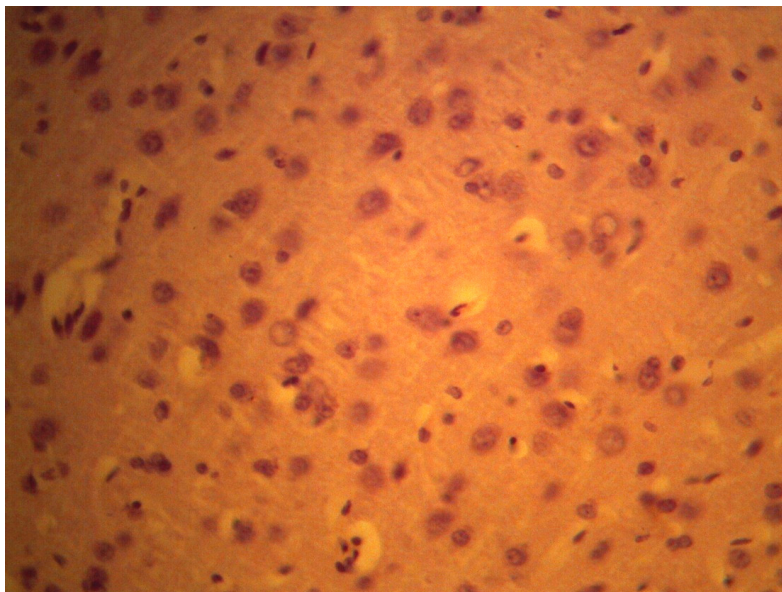

Figure 7. On the 15th day from the beginning of treatment. An easy pericellular edema of the brain tissue. Color: hematoxylin eosin

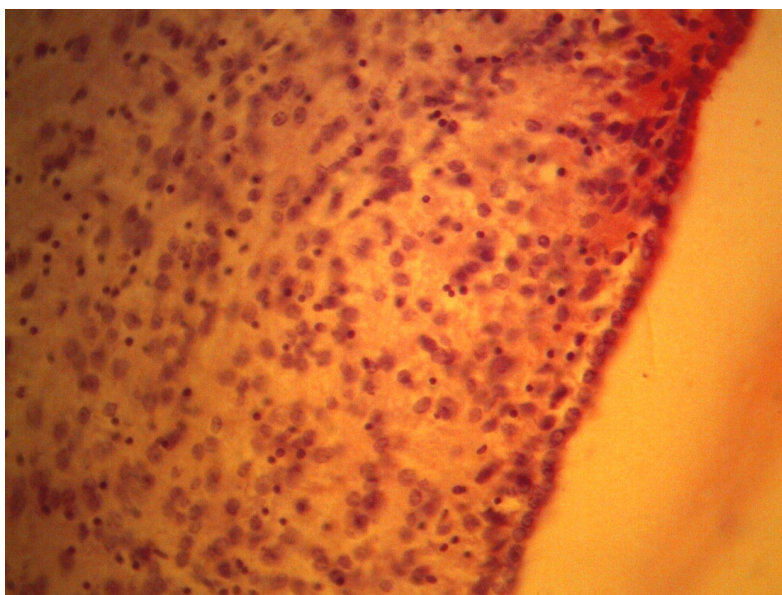

Figure 8. At 20th days from the start of treatment. The walls of the lateral ventricle of the brain are ependymocytes homogeneous. Sub-ependymic vessels are full-blooded. Color: hematoxylin eosin

The cells covering the ventricles of the brain are hyperchromous, sometimes two-rowed, and in some places papillate branches are visible, their vessels are full-blooded, hence the cell nutrition is satisfactory (Fig. 8).

Conclusion: A comparative morphological study of brain structures of white rats of II and III experimental groups showed a significant difference in the dynamics of recovery of brain microstructures in white rats subjected to the action of ozonized cerebrolysin. In the rats of the second experimental group, signs of ischemia and hypoxia are more pronounced, and compensatory changes

in astrocytes and glial structures are less pronounced. In the third experimental group, the ventricular cells of the brain are hyperchromic, sometimes two-rowed and form papillary branches, are hyperimular.

Thus, by reshaping the obtained results, it can be concluded that the administration of ozonized cerebrolysin to rats with consequences of the transferred paralysis of the central nervous system has a beneficial effect on the neuroplasticity of the brain structures during the treatment. Improves the trophism of cells, which stimulates their compensatory possibilities.

References:

1. Goncharova T. A. Effect of ozonized saline on the functional state of the liver of rats in norm and with sarcoma 45. Dis. ... Ph.D. in N. Novgorod; – 1998.– 135 p.
2. Dudina E. V. Effect of ozonized physiological solution on the oxidative processes of the brain in the norm and in the early postresuscitation period. A / p Dis. ... Ph.D. N. Novgorod, – 2003.
3. Modern ideas about the morphological basis of infantile cerebral palsy. V. D. Levchenkova, K. A. Semenova Journal of Neurology and Psychiatry. S. S. Korsakov. – No. 7. – 2012.
4. Efficacy of cytoflavin in disseminated encephalomyelitis in children N. V. Skripchenko, G. P. Ivanova, E. Yu. Skripchenko, E. S. Egorova, A. V. Surovtseva Neuroscience and Psychiatry them. S. S. Korsakov. – No. 12. – 2017.
5. The use of Cerebrolysin in pediatric neurology Morozova Journal for Physicians Difficult patient magazine issue: November – 2007.
6. Pharmacokinetic and pharmacodynamic synergism between neuropeptides and lithium in the realization of neurotrophic and neuroprotective effects of cerebrolysin. Gromova I. Yu., Torshin I. V., Gogoleva A. V., Pronin E. V., Stelmashuk N. K. Isaev Henrichs, V. I. Demidov A. Yu. Volkov, G. L. Khaspekov, O. P. Alexandrova Journal of Neurology and Psychiatry. S. S. Korsakov. – No. 3. – 2015.

Ochilov Komil Rakhimovich,
Ph D., associate professor,
Head of the Chair of Forensic
Medicine and Pathological Anatomy
of the Bukhara State Medical Institute,
Bukhara, Uzbekistan
E-mail: ss-1961@mail.ru

INFLUENCE OF IONS OF HEAVY METAL SALT ON BREATHING AND OXIDATIVE PHOSPHORYLATION OF MITOCHONDRIA OF RAT LIVER

Abstract: In experiments *in vitro* it is established, that heavy metals Co^{2+} and Cd^{2+} effectively influence breath and system of mitochondriosome. Ions Co^{2+} inhibits breath mitochondriosome in conditions V_3 and V_4 , separating oxidizing phosphorylation (OPh). Effect Cd^{2+} on breath and OPh mitochondriosome differs from action Co^{2+} and other heavy metals. Thus, Cd^{2+} in low concentration increases breath mitochondriosome, in high concentration inhibits it. The results received in the present work expand traditional representations about various mechanisms of action of heavy metals on a biopower metabolism of a cell.

Keywords: Ions heavy metals, oxidative phosphorylation, mitochondrios, hepatices.

Salts of heavy metals are present in the environment and are the cause of many chronic diseases of humans and animals [1]. At the heart of the toxic effect of heavy metals on a living organism is the damage of cells and their organelles, accompanied by their functional or structural-functional changes. Among heavy metals, cadmium, cobalt, lead, zinc, aluminum, chromium, etc. are dangerous for life and health.

Cadmium can exert mutagenic and teratogenic effects on the body, which lead to insignificant destruction of the cellular apparatus of the placenta and embryonic tissues in the early stages of organogenesis [2].

The increase in the hepatosomatic index and the presence of pronounced necrotic changes in the liver is the main manifestation of the effect of high doses of cadmium [3]. In the work [4], it was explained that the hepatotoxic effect of cadmium leads to the formation of significant changes in the biochemical indicators of human blood. In conditions of chronic poisoning, cadmium leads to destruction of the liver and damage to the kidneys, since it has a pronounced hepatotoxic and nephrotoxic effect [5].

The toxic effect of cadmium, leading to the development of mitochondrial dysfunction. The growth of ischemic events that arise due to damage to the endothelial cells of the liver vessels leading to the formation of hepatocellular trauma [6]. In the experimental study [7], it was found that mitochondria and the endoplasmic hepatocyte network possess the greatest sensitivity to the toxic effect of cadmium.

Chronic exposure to xenobiotic leads to the formation of structural changes in the cells of the hepatic tissue, which manifests itself in the form of swelling and changes in the shape of the mitochondria, as well as in the appearance of signs of their biodegradation. The toxic effect of cadmium contributes to the development of total hydropic dystrophy of hepatocytes, which sometimes turns into balloon dystrophy. In acute intoxication with cobalt salts, leukocytes, erythrocytes, increased hemoglobin concentration in the blood; in chronic: leucopenia, erythrocytes, increased hemoglobin concentration. At intoxication by salts of metals rupture of membranes of erythrocytes of rats is revealed [8].

The purpose of the work was to study the effects of heavy metal salts on breathing and oxidative phosphorylation (OP) of rat liver mitochondria in *in vitro* experiments.

Materials and methods. Mitochondria were isolated from the liver of rats weighing 150–200 g by the method of Schneider's differential centrifugation in a isolation medium containing 250 mM sucrose, 10 mM

tris chloride, 1 mM EDTA, pH 7.4. The content of the mitochondrial protein was determined colorimetrically according to the biuret method.

The rate of mitochondrial respiration in the states V3 and V4 was measured with the OH-102 polarograph (Hungary, Radelkis) with an open platinum electrode. The values of DK and ADP / O were determined by the Chance method [5], proceeding from the fact that the amount of oxygen in 0.5 ml of incubation medium at 26 °C is 250 ng – oxygen atom. In the experiments incubation medium (SI) was used: sucrose – 125 mM, KCl – 60 mM, KH₂PO₄ – 2.5 mM, succinate – 5 mM, tris-HCl – 5 mM, pH-7.4; additions of ADP to a final concentration of 0.2 mM; concentration of protein M × 3 mg/ml. The rotenone was added to the incubation medium to prevent the accumulation of oxaloacetic acid, a competitive inhibitor of succinate oxidation.

Results and discussion. When studying the effect of cobalt ions on respiration and RP of mitochondria in vitro experiments, it was shown that Co₂₊ ions inhibit respiration in the metabolic states of V3 and V4. At the same time, the parameters of respiratory control (DK) and ADP/O decrease. However, there is no complete disconnection of the formatting object. Significant inhibition of respiration and disconnection of the mitochondrial phase of OH is also observed when exposure to higher concentrations of Co₂₊ (5–10–5M – 10–4M).

It is known that unlike Zn₂₊, low concentrations of Co₂₊ do not affect the respiratory chain, then one of the causes of respiratory depression and separation of OP by Co₂₊ ions is possibly a decrease in the membrane potential due to an increase in passive permeability for charged membrane particles or a change in the state of CsA-sensitive pores.

According to Professor KT Almatova et al. [9] Co₂₊ ions are activators of cytochrome c-oxidase and rotenon-sensitive NADH-oxidase system of mitochondrial membranes. These authors showed that the increase in the activity of these enzymes depends on the concentration of CoCl₂. Co₂₊ ions also activate the succinate oxidase systems of the mitochondrial respiratory chain. The authors conclude that the presence of Co₂₊ ions in the medium leads to significant changes in the electron transport chain of the mitochondria [10, 11].

S.M. Korotkov and co-authors [12] found that the action of Cd₂₊ ions on respiration and RP Mx is pecu-

liar: relatively low concentrations stimulate respiration in the states V3 and V4, while the coefficients of DK and ADP/O decrease slightly.

Under these conditions, high concentrations of this caution inhibit respiration in both states and lead to complete disconnection of the OB with removal of the DC mechanism. In experiments in vitro, we studied the effect of Cd₂₊ on respiration and RP of rat liver mitochondria. Cd₂₊ ions in comparatively low concentrations increased the indices of V3 and V4, however, the coefficients of DK and ADP / O slightly decreased. The addition of Cd₂₊ to the suspension to a final concentration of 1 × 10⁻⁵ M also caused simultaneous stimulation of respiration in the V3 and V4 states, while the values of DK and ADP/O were just below the control level. A further increase in the concentration of Cd₂₊ in the medium led to respiratory depression.

With an increase in the Cd₂₊ concentration to 2 × 10⁻⁵ M, the mitochondrial respiration in the V3 state was inhibited by 67%. Suppression of respiration was also observed in the V4 state. As a result of marked inhibition, the value of the DC coefficient decreased to 1.61; ADP/O-1.3. At a concentration of Cd₂₊ + 7.5 × 10⁻⁵ M, the coefficient of DC decreased to 1, i.e. there was a complete disconnection of the PF with the removal of the DC mechanism.

In our experiments, dithiothreitol (DTT) removes the effect of Cd₂₊ on respiration and the OB system. It is known that DTT protects thiol groups of mitochondrial membranes. It can be assumed that the effect of Cd₂₊ on the function of mitochondrial membranes is mediated through thiol groups of membranes.

The mechanisms of action of Cd₂₊ on respiration and RP of mitochondria are quite complex and attract many researchers. As early as the 1980s, it was shown that Cd₂₊ increases the permeability of mitochondrial membranes for cations and activates respiration. Higher concentrations of Cd₂₊ inhibit respiration in the presence of OP disentrers.

The effect of Cd₂₊ on the function of mitochondria depends on its concentration. Apparently, in the presence of high concentrations, the activity of succinate dehydrogenase, cytochrome C oxidase and other enzymes are inhibited, as a result of which respiration is suppressed.

The effect of Cd₂₊ on respiration is partially removed by heavy metal ions and the classical inhibitor of Ca₂₊

transport in Mx-ruthenium red, however, the mechanisms of action of these agents have not been fully elucidated.

It should be noted that the effects of Cd_2+ on respiration and RP Mx differ from that of Co_2+ . At higher concentrations, Co_2+ does not completely disentangle the OV, while Cd_2+ completely disconnects the mitochondrion phase of the OV.

Our investigations carried out in this paper establish that the ions Co_2+ and Cd_2+ disunite the OP. However, mechanisms of disengagement of OBs by heavy metals have not been finally established. To date, the mechanisms of the action of the uncouplers of PF have been established. All mechanisms and postulates of the action of uncouplers of PF suggest that they facilitate the transition of protons ($H+$) or other charged particles directly through the mitochondrial membrane.

The motor of the formation of ATP from ADP and inorganic phosphate is just the proton gradient on both sides of the membrane Mx, which is not permeable to $H+$, supported by biological oxidation reactions. However, the molecules of the uncouplers – protonophores –

can bind $H+$, and the ionophores some cation and transfer them through the internal membrane, as a result of which a decrease in MP membranes and disconnection of the OB is observed.

Perhaps in our experiments, heavy metal ions interact with mitochondrial membranes and induce passive permeability. As a result, there is a decrease in the membrane potential and separation of the mitochondrion phase of the OH.

Thus, in vitro experiments it has been established that the heavy metals Co_2+ and Cd_2+ that we study effectively influence respiration and the system of mitochondrial phase. Ions of Co_2+ inhibit the respiration of mitochondria in the states V3 and V4, separating the OP. The effect of Cd_2+ on respiration and RP of mitochondria differs from that of Co_2+ and other heavy metals. In this case, Cd_2+ at low concentrations increases the respiration of mitochondria, at high concentrations it inhibits it. The results obtained in this paper broaden the traditional ideas about the various mechanisms of action of heavy metals on the bioenergetic metabolism of the cell.

References:

1. Hodgson E., Levi P.E. Pesticides: An important but underused model for the environmental health sciences // *Environ. Health Persp.*– 1996; 1 (104): 97–106.
2. Chen K. L., Liu S. H., Su C. C. Mercuric compounds induce pancreatic islets dysfunction and apoptosis in vivo // *International Journal of Molecular Sciences.*– 2012; 10 (13): 12349–66.
3. Mazzei V., Longo G., Brundo M. V. et al. Bioaccumulation of cadmium and lead and its effects on hepatopancreas morphology in three terrestrial isopod crustacean species // *Ecotoxicology and Environmental Safety.*– 2014; 110 (30): 269–79.
4. Adams S. V., Passarelli M. N., Newcomb P.A. Cadmium exposure and cancer mortality in the Third National Health and Nutrition Examination Survey cohort // *Occupational and Environmental Medicine.*– 2012. – No. 2 (69): 153–56.
5. Blum J. L., Rosenblum L. K., Grunig G. et al. Short-term inhalation of cadmium oxide nanoparticles alters pulmonary dynamics associated with lung injury, inflammation, and repair in a mouse model // *Inhalation Toxicology.*– 2014; 1 (26): 48–58.
6. Gutnikova A. R., Baybekov I. M., Ashurova D. D. et al. Possibility of restoration of liver structure during intoxication with salts of heavy metals // *Labor Medicine and Industrial Ecology.*– 2012; 6: 32–5.
7. Comparative action of cobalt salts on the balance of proteins and fluid in the body of rats [Text] G. R. Khanturina // *Modern high technology: Mat. Int. Conf. (Egypt, – 2011)* // *Between the folk magazine butt. And the foundation. Research.*– 2011; 4 5: 61–2.
8. Almatov K. T., Saidkhodzhaev G. M., Klemsheva L. S., Irgashev M. S. Protective effect of cobalt in the inactivation of succinic oxidase and NAD.N-oxidase respiratory chain mitochondria phospholipase A2 // *Uzb. biol. zhurn. (Tashkent)* – 1998; 2: 32–5.
9. Ibragimova K. M., Almatov K. T. Effect of cobalt ions on the respiratory function of mitochondria // *Science, education, technology. International scientific journal.*– 2003; 1–2: 104–9.

10. Saidkhodzhaev G. M., Irgashev M. S., Klemesheva L. S., Almatov K. T. Influence of cobalt ions on the activity of polyenzyme systems of the respiratory chain of rat liver mitochondria // Uzb biol. zhurn. (Tashkent).– 1996; 1–2: 17–20.
11. Korotkov S. M., Glazunov V. V., Rosengart E. V. et al. Influence of hydrophilic cadmium complex with anabasin on energized mitochondria of rat liver // Reports of the Academy of Sciences of Russia.– 1996; 4 (346): 552–4.

*Tashkenbaeva Eleonora Negmatovna,
doctor, of Medical Sciences, associate professor,
Head of the Department of Internal Medicine No. 2
of Samarkand State Medical Institute,
E-mail: eleonora_88@mail.ru*

*Abdieva Gulnora Alievna,
assistant professor, of the Department of Internal Medicine No. 2
of Samarkand State Medical Institute
E-mail: Gulnora.abdieva@bk.ru*

FEATURES OF ISCHEMIC HEART DISEASE IN ASSOCIATION WITH CLIMACTERIC CARDIOPATHY

Abstract: In the article, the analysis of the clinical examination data and the results of the laboratory-instrumental study was conducted in 113 women with chest pain complaints in inpatient treatment, which were divided into 2 groups: the first group included 60 (53%) of patients with IHD combined with climacteric cardiopathy, the 2nd comparison group included 53 (47%) patients with IHD. It was revealed that in patients with IHD in combination with climacteric cardiopathy, there was an increase in body mass index, presence of abdominal obesity, diabetes mellitus was more often detected and had a longer, unfavorable course, which contributed to unfavorable course, progression and development of cardiovascular disasters.

Keywords: ischemic heart disease, climacteric cardiopathy, risk factors.

Introduction. In recent years, interest in the problem of gender differences in cardiovascular risk factors has attracted the attention of the medical community [5, 3]. It is known that women of childbearing period in contrast to men have a low risk of cardiovascular events [7]. However, after the onset of menopause, the likelihood of developing CVD, including IHD, is significantly increased [4, 6, 7]. A significant increase in cardiovascular risk in postmenopause is due to a complex effect on the body of a number of external and internal risk factors, some of which are not modifiable (age, genetic predisposition, etc.), while others can be corrected during primary prevention of CVD. Moreover, the menopause itself can be considered as a risk factor for the development of CVD [4, 8], which affects the cardiovascular system through redistribution of adipose tissue, various metabolic, hemodynamic, proinflammatory changes and direct effects of estrogen deficiency on the uterus the distal wall [1]. The problems of diagnosis and differential diagnosis of hormonal cardiopathy and coronary heart disease in recent years have attracted increasing attention of cardiologists. Climacteric cardiopathy (CCP) and

coronary insufficiency occur in the same age period, so their combinations are possible. The basis for such an assumption is the emergence along with cardiology of compressive pain behind the sternum according to the type of angina pectoris, the association of pain with physical exertion, the effect of nitroglycerin, indirect signs of atherosclerosis: X-ray detected compaction of the aorta, propensity to hyperlipidemia, hypertension [2]. Treatment of ischemic heart disease combined with CCP has its own peculiarities and the effectiveness of therapy is significantly reduced by using only modern standards for the treatment of coronary heart disease and the neglect of concomitant pathology. This lengthens the process of treatment, recovery and reduces the quality of life. Objective: To study the features of the course of IHD in combination with climacteric cardiopathy.

Material and methods of investigation. The paper analyzed 113 women aged 40 to 55 years (mean age 46.8 ± 3.2 years) with coronary artery disease (progressive angina pectoris, climacteric cardiomyopathy), are examined and treated in the emergency department treatment of the Samarkand branch of the Republican Scientific

Center of Emergency Medical Aid from 2015–2017. Inclusion criteria were: female gender, age from 40 years to 55 years, diagnosed earlier coronary heart disease, in particular, progressive angina pectoris, confirmed by a gynecologist diagnosed peri- and post-menopausal patients' informed consent for participation in the study. Of the 113 patients diagnosed with IHD in combination with the CCP, two groups were formed for subsequent comparative analysis: the 1st group included 60(53%) patients with IHD combined with climacteric cardiopathy. All patients had no menstruation for more than 1 year. In 51(85%) patients of this group, menopause was physiological, in the remaining 9(15%) – surgical. The 2nd comparison group included 53(47%) patients with IHD who had a regular or irregular menstrual cycle, or no menstruation for less than 1 year. At discharge from the hospital, all patients along with standard antianginal and disaggregant therapy were prescribed a cimicifuga preparation. In each test group was carried out a clinical examination and a thorough history, in accordance with conventional techniques to ascertain complaints duration of the disease, assessment of risk factors (RF) of ischemic heart disease, a history of complications – MI, CHF. Evaluated following risk factors coronary artery disease: dyslipidemia (DLP), arterial hypertension (AH), impaired glucose metabolism in the form of diabetes mellitus (DM), obesity and the nature of the distribution of body fat, family history.

Results and discussion. As the results of the study showed, the total cholesterol (TCH) content was 6.8 ± 2.5 mmol/l in the first group and 6.1 ± 2.0 mmol/l in the second group, $p = 0.05$. The level of HDL was 0.9 ± 0.36 mmol/l in the first group and 1.24 ± 0.38 mmol/l in the second group, $p = 0.03$. The level of LDL was 4.73 ± 0.74 and 3.72 ± 0.81 mmol/l, respectively, $p < 0.001$. In addition, hypertriglyceridemia was noted in both groups: the TG level was 4.1 ± 0.5 mmol/l in the first group and 3.74 ± 0.38 mmol/L in the second group, $p < 0.001$, the atherogenicity coefficient was 5.3 and 4.1, respectively, $p < 0.001$. The presence of AH in both groups did not differ statistically – 46(87%) and 57(95%), respectively, $p = 0.09$. Patients of the first group had higher maximum BP figures (212 mm Hg vs. 173 mm Hg, $p = 0.002$), a longer course of AH (9.8 ± 3.5 yr versus 7.2 ± 3 years, 7 years, $p = 0.001$), and higher figures like SBP (156.7 mm Hg vs. 137.4 mm Hg, $p = 0.005$) and DBP (99.8 mm

Hg vs. 80,6 mm Hg, $p = 0,005$), against the background of taking antihypertensive drugs.

Type 2 diabetes mellitus was detected in 8(13.3%) patients in the first group and in 6(12.3%) in the second group, $p = 0.002$. The duration of diabetes, according to the history, was 6.5 ± 3.0 years and 4.1 ± 1.5 , respectively, $p = 0.014$. The combination of two or more RF is often found in both groups, the first group differed only in the more frequent combination of AH and DM and AH, SD, DLP ($p = 0.02$ in both cases). Obesity of the first degree in the first group in 27(45%), in the second group was found in 11(21%), $p = 0.15$, overweight in 30(50%) and 29(55%) patients, respectively, $p = 0.53$. Mean BMI in the first group was 31.4 ± 4.2 kg/m², in the second group – 28.1 ± 3.7 kg/m², $p = 0.001$, and abdominal obesity in the groups was 27(45%) and 15(28%) patients, respectively, $p = 0.01$.

Weighted family history was noted in 29(48%) patients in the first group and in 11(21%) in the second group, $p = 0.005$.

When analyzing the results of ECG, among pathogens of the first group, the pathological Q wave was noted in 19(51%) patients, and the change in the final part of the ventricular complex (ST segment depression, negative T wave) in 17(46%) patients. With the same frequency, these changes also occurred in the second group – in 15(60%) and 10(40%) patients, respectively.

According to the results of EchoCG, in both groups, the violation of local contractility was registered in 29(78%) and 17(68%) patients, respectively ($p = 0.32$), LVH in 26(70%) and 12(48% = 0.032), a decrease in EF (< 40%) in 12(32%) and 6 (24%), respectively ($p = 0.229$).

Patients with IHD combined with CCP were divided into two subgroups depending on the therapy received: A group comprised 39 women, who included the preparation of cimicifuga in the complex of therapy; the second group consisted of 21 women receiving traditional therapy. When comparing RF after treatment in women adherent to taking cimicifuga, there were lower values of SBP and DBP (120.5 mm Hg and 80.6 mm Hg), compared with women who did not take cimicifuga (135, 4 mm Hg and 93.5 mm Hg). TCH was 6.2 mmol/l versus 6.8 mmol/l. A lower incidence of cardiovascular events, such as acute coronary syndrome, acute myocardial infarction (11% compared with 55% in the group of wom-

en who stopped taking cimicifuga, $p = 0.04$), progression of CHF (22 and 70%, respectively, $p \leq 0.04$).

Conclusion. Thus, it is necessary to differentiate climacteric cardiopathy and coronary heart disease, as well as determine the degree of their expression in a combined course. The content of LDL, TG and the coefficient of atherogenicity in the group of women with IHD in combination with the CCP were higher. Attention was also drawn to the lower content of HDL in the group of women with IHD in combination with the CCP. In patients with coronary heart disease in combination with the CCP, there was an increase in BMI and the presence of abdominal obesity, which contributed to the adverse course, progression and development of cardiovascular disasters. In women with coronary artery disease in combination with the CCP, DM was significantly more

frequently detected and was characterized by a longer, unfavorable course. Selection of methods for treatment of patients with IHD in combination with the CCP in accordance with the results obtained requires a collegial decision involving specialists from related specialties. Improving health status, predicting the disease, preventing disability and increasing the life expectancy of women with IHD in combination with the CCP, largely depends on the timeliness of preventive interventions and the initiation of an appropriately selected treatment. When assigned to patients with IHD in combination with the CCP of the drug cimicifuga were lower values of blood pressure (both systolic and diastolic), TCH and fasting glucose. In the group of women, adherent to long-term therapy with cimicifuga, there was a lower incidence of myocardial infarction and progression of CHF.

References:

1. Anichkov D. A., Shostak N. A., & Zhuravleva A. D. Menopauza i serdechno sosudistiy risk. Racional'naya farmakoterapiya v kardiologii [Menopause and cardiovascular risk. Rational pharmacotherapy in cardiology], 1(1).– 2005.
2. Simonenko V. B., CHaplyuk A. L., Teslya A. N., & Frolov V. M. Diagnostika i lechenie ishemicheskoy bolezni serdca v sochetanii s klimaktericheskoy kardiopatiy [Diagnosis and treatment of coronary heart disease in combination with climacteric cardiopathy]. Klinicheskaya medicina, 90(6).– 2012.
3. Yureneva S. V., Mychka V. B., Il'ina L. M., & Tolstov S. N. Osobennosti faktorov riska serdechno-sosudistyyh zabollevaniy u zhenshchin i rol' polovyh gormonov [Features of risk factors for cardiovascular disease in women and the role of sex hormones]. Kardiovaskulyarnaya terapiya i profilaktika, 10(4),– 2011.– P. 128–135.
4. Dessapt A., & Gourdy P. Menopause and cardiovascular risk. Journal de gynecologie, obstetrique et biologie de la reproduction, 41(7 Suppl), – P. 13–9.– 2012.
5. Mosca L., Benjamin E. J., Berra K., Bezanson J. L., Dolor R. J., Lloyd-Jones D. M., ... & Zhao D. (2011). Effectiveness-based guidelines for the prevention of cardiovascular disease in women-2011 update: a guideline from the American Heart Association. Circulation, CIR-0b013e31820faaf8.
6. Ratiani L., Parkosadze G., Cheishvili M., Ormotsadze G., Sulakvelidze M., & Sanikidze T. Role of estrogens in pathogenesis of age-related disease in women of menopausal age. Georgian Med News, 203,– 2012.– P. 11–6.
7. Roger V. L., Go A. S., Lloyd-Jones D. M., Adams R. J., Berry J. D., Brown T. M., & Fox C. S. Heart disease and stroke statistics – 2011. update: a report from the American Heart Association. Circulation, 123(4), e18.– 2011.
8. Wellons M., Ouyang P., Schreiner P. J., Herrington D. M., & Vaidya D. Early menopause predicts future coronary heart disease and stroke: the Multi-Ethnic Study of Atherosclerosis (MESA). Menopause (New York, NY), 19(10). – P. 1081.– 2012.

*Turakulov Rustam Ismatullaevich,
doctor, cardiologist at the 3rd clinic
of the Tashkent Medical Academy,*

*Gadayev Abdugaffar Gadayevich,
professor, Department of Internal Medicine No. 3,
Tashkent Medical Academy, Uzbekistan
E-mail: evovision@bk.ru*

DYNAMICS OF CYTOKINES AND LEVEL OF HEPSIDINE IN PATIENTS WITH CHRONIC HEART FAILURE WITH ANEMIA

Abstract: the study examined the dynamics of cytokines and hepcidin level in patients with chronic heart failure, depending on the presence or absence of anemia in them. At the beginning of the study, Hepsidine was raised in the second subgroup of 23.3 ± 3.5 ng/ml, in the first subgroup and in the hanging comparison group, these indices were not noted. After 6 months there was a decrease in the level of Gepsidin in the second subgroup to 19.2 ± 0.06 ng/ml ($p > 0.05$). Correlation analysis of hepcidin and cytokine indices in patients with CHF with anemia revealed a direct weak correlation between hepcidin and IL-6 concentration in the second subgroup.

Keywords: chronic heart failure, iron deficiency anemia, anemia of a chronic disease, hepcidin, interleukins.

Chronic heart failure (CHF) – occupies one of the leading places in the structure of morbidity and disability among the world's population. This syndrome is still one of the most common, severe, and also prognostically unfavorable complications of all diseases of the cardiovascular system and affects 1.5–2% of the entire world population, the incidence is 5–10 cases per 1000 people annually [4].

In the past decade, the possibilities of treating anemia in patients with CHF have been actively studied [6]. Anemia is an independent predictor of the high risk of adverse events in patients with CHF.

At present, the etiology and pathogenesis of anemia developing in patients with CHF is quite diverse. The following are considered as the main ones: hemodilution, renal dysfunction (the so-called cardiorenal anemia syndrome), iron metabolism disorders and a number of other factors. The development of anemia of chronic diseases (AChS) in patients with CHF as a consequence of neurohumoral reactions characteristic of them, including the activation of pro-inflammatory cytokines (tumor necrosis factor, interleukin-6, etc.) is also not excluded. Special attention should be paid to the possibility of oppression of erythropoiesis against the background of taking ACE in-

hibitors and angiotensin II receptor blockers, which need to be used in the treatment of patients with CHF [5].

Recently, when discussing the problems of the pathogenesis of ACh, special attention is paid to hepcidin, an acute-phase protein with the properties of a regulator of iron metabolism in the body, blocking the transport of iron in various places (including enterocytes and macrophages). The level of hepcidin correlates with the iron content in the liver and the level of hemoglobin. Synthesis of hepcidin is enhanced by inflammation (under the influence of IL-6) and under conditions of iron overload. ACh are very heterogeneous in nature [1, 3], differ in their origin and simultaneous participation of many factors that regulate erythropoiesis.

To date, only a few studies have examined the role of hepcidin in CHF and AChS, and these data are contradictory [2, 7].

Objective: to assess the relationship between inflammatory markers and the hepcidin level in patients with chronic heart failure and anemia. **MATERIALS AND METHODS:** The study included 115 patients with CHF, the main cause of hospitalization was heart failure. The etiological factor of CHF in all patients was CHD.

The patients were divided into two groups: The main group of 75 CHF patients with anemia was divided into two subgroups, which included patients with CHF of iron deficiency anemia (CHD) and patients with CHF of chronic anemia (ACH), respectively. The second control group included patients with CHF without anemia. The first subgroup included 40 CHF patients with IDA with an average age of 64.8 ± 1.08 years; The second subgroup included 35 patients with CHF with ACH with an average age of 65.3 ± 1.48 years; The second group included 40 patients with CHF without anemia with an average age of 61.4 ± 1.13 years.

The first group was treated with intravenous iron against the background of standard therapy of CHF during hospitalization, in the comparison group patients received standard therapy for decompensated chronic insufficiency.

Patients were observed for 6 months. Clinical status, laboratory parameters, quality of life and ECHO-cardiography were evaluated initially, 6 months after the start of treatment.

Results of the study

Since the inclusion criterion was hospitalization due to CHF, the study included patients with II–III

FC CHF on NUNA. In the first subgroup there were 14(34.4%) patients of II FC and 26(65.6%) of III FC, in the second 10 (28.5%) and 25(71.5%) patients, respectively. In the control group there were 16 (40.0%) patients of II FC and 24(60.0%) of III FC.

To determine the clinical and laboratory features of anemia in patients with CHF, a comparative analysis was performed depending on the presence or absence of anemia in them.

The mean hemoglobin level was 101.4 ± 0.48 g /L in the IDA group, 104.3 ± 0.8 g / L in the ACS group and 126.0 ± 0.58 g / L in the comparison group, the mean ferritin- 102.9 ± 8.5 mg/l, 267.5 ± 8.54 and 389.5 ± 11.6 mg/l, respectively. The serum iron values before the start of treatment were only slightly below the norm in the IDA and ACH groups 7.94 ± 0.21 mol/L and 6.14 ± 4.12 mol/L. The mean level of hepcidin was significantly higher in the AChS group 23.3 ± 3.5 . In the IDA group and the control group, the same indicator was 7.6 ± 1.3 and 5.7 ± 1.02 . For the rest of the laboratory parameters, the patients of both groups did not differ significantly.

Table 1. – Dynamics of proinflammatory cytokines in blood plasma in patients before and after treatment

Indicators	Treatment period	A group		Control group	
		CHF FC II, n = 14	CHF FC III, n = 26	CHF FC II, n = 16	CHF FC III, n = 24
IL-1	Before	17.9 ± 2.1	20.8 ± 1.3	16.4 ± 0.72	18.6 ± 1.93
	After	$9.6 \pm 1.2^{\wedge\wedge}$	$10.8 \pm 1.23^{\wedge\wedge\wedge}$	7.4 ± 1.3	8.7 ± 0.92
IL –6	Before	20.4 ± 1.8	$22.6 \pm 1.3^*$	17.2 ± 1.78	18.9 ± 1.3
	After	$10.3 \pm 0.98^{\wedge\wedge\wedge}$	$12.2 \pm 1.43^{\wedge\wedge\wedge}$	7.7 ± 1.43	8.6 ± 1.2
TNF- α	Before	$19.6 \pm 0.62^{***}$	21.8 ± 1.64	15.9 ± 0.72	17.4 ± 1.93
	After	$9.2 \pm 1.33^{\wedge\wedge\wedge}$	$11.4 \pm 1.67^{\wedge\wedge\wedge}$	6.8 ± 2.1	8.2 ± 2.3
Indicators	Treatment period	B group		Control group	
		CHF FC II. n = 10	CHF FC III. n = 25	CHF FC II. n = 16	CHF FC III. n = 24
IL-1	After	18.2 ± 0.72	21.1 ± 1.93	16.4 ± 0.72	18.6 ± 1.93
	Before	$16.2 \pm 1.12^{***}$	$18.3 \pm 1.21^{***}$	7.4 ± 1.3	8.7 ± 0.92
IL –6	After	$26.6 \pm 1.7^{***}$	$29.7 \pm 1.3^{***}$	17.2 ± 1.78	18.9 ± 1.3
	Before	$19.7 \pm 0.98^{***\wedge\wedge}$	$22.8 \pm 1.32^{***\wedge\wedge\wedge}$	7.7 ± 1.43	8.6 ± 1.2
TNF- α	After	$20.2 \pm 0.72^{***}$	$24.7 \pm 1.93^{**}$	15.9 ± 0.72	17.4 ± 1.93
	Before	$15.6 \pm 1.42^{**\wedge\wedge}$	$19.3 \pm 0.89^{***\wedge}$	6.8 ± 2.1	8.2 ± 2.3

Note: * – differences relative to the control group of the group are significant (* – $P < 0.05$, ** – $P < 0.01$, *** – $P < 0.001$); \wedge – the differences with respect to indicators before treatment are significant (\wedge – $P < 0.05$, $\wedge\wedge$ – $P < 0.01$, $\wedge\wedge\wedge$ – $P < 0.001$)

Six months after the start of treatment, the patients in the first subgroup had a significant change in hematological parameters compared to the baseline: the mean hemoglobin level increased 126.6 ± 0.78 g/l ($P < 0.001$), hematocrit up to $40.1 \pm 0.19\%$ ($P < 0.001$). In the second ACS subgroup, hemoglobin and hematocrit levels varied 120.1 ± 1.79 g/l ($P < 0.001$), and $39.7 \pm 0.17\%$, respectively, during the study.

Against the background of intravenous therapy in the first subgroup, there was a significant increase in serum iron, ferritin, transferrin saturation, and a decrease in transferrin level, which shows the effectiveness of Venofer in correction of iron deficiency. In the second subgroup, the change in these indicators was statistically unreliable.

Indicators of levels of tumor necrosis factor, interleukin 1, interleukin 6 were investigated. At the beginning of the study, the level of IL-1 in patients in the control group with CHF without anemia with FC II–III was 16.4 ± 0.72 , 18.6 ± 1.93 ng/ml, IL-6– 17.2 ± 1.78 – 18.9 ± 1.3 ng/ml, and the level of TNF- α was 15.9 ± 0.72 , 17.4 ± 1.93 ng/ml, respectively.

In the I-A group of patients with the presence of CHF with ZDA with FC II–III IL-1 was equal to 17.9 ± 2.1 – 20.8 ± 1.3 ng/ml, IL-6– 20.4 ± 1.8 – 22.6 ± 1.3 ng/ml, and the level of TNF- α was 15.9 ± 0.72 , 17.4 ± 1.93 ng/ml, respectively.

In group I-B patients with CHF with AChS with FC II–III IL-1 was 18.2 ± 0.72 – 21.1 ± 1.93 ng/ml, IL-6–

-26.6 ± 1.7 – 29.7 ± 1.3 ng/ml, and the level of TNF- α was 20.2 ± 0.72 , -24.7 ± 1.93 ng/ml, respectively.

In comparison with the control group, the level of interleukin-1 in the I-A group of patients is higher by 9.1–11.8% ($P < 0.05$), interleukin-6 is 18.6–19.5% ($P < 0.01$), and TNF- α – 27.1–41.0 ($P < 0.01$)%, respectively.

In the I-B group of patients, the level of interleukin-1 is higher by 10.9–13.4% ($P < 0.05$), interleukin-6 is 54.6–57.1 ($P < 0.001$)%, TNF-27, 1 – 41.0 ($P < 0.01$)% than in the control group.

The correlation between hepcidin and proinflammatory cytokines has been studied in not many studies and conflicting data have been obtained. When studying the correlation between a statistically significant high level of proinflammatory cytokines and playing an important role in the pathogenesis of chronic anemia with hepcidin, a weakly positive relationship was established between hepcidin in patients with CHF C AChS (I-B Guppa) and IL-1 ($r = 0.24$ $P < 0.05$), and between IL-6 there is a strong positive relationship ($r = 0.49$, $P < 0.05$), between TNF- α – a medium-positive bond ($r = 0.37$, $P < 0.05$).

Conclusion: The results of our study showed that the level of hepcidin was significantly higher in patients with CHF and AChZ, as well as in patients with CHF with anemia, a correlation between hepcidin and IL-6 in the AChS group was found.

In both subgroups of patients with anemia, there was an increase in the level of cytokines IL-1, IL-6, TNF- α .

References:

1. Divakaran V., Mehta S., Yao D., Hassan S. et al. Hepcidin in anemia of chronic heart failure // *Am J Hematol.* – 2011. – Vol. 86 (1). – P. 107–9.
2. Martinez-Ruiz A., Tornel-Osorio P.L., Sanchez-Mas J. Soluble TNF- α receptor type I and hepcidin as determinants of development of anemia in the long-term follow-up of heart failure patients // *Clin Biochem.* – 2012. – Vol. 45. – P. 1455–8.
3. Matsumoto M., Tsujino T., Lee-Kawabata M. et al. Iron regulatory hormone hepcidin decreases in chronic heart failure patients with anemia // *Circ J.* – 2010. – Vol. 74 (2). – P. 301–6.
4. Mosterd A., Hoes A. W. Clinical epidemiology of heart failure // *Heart.* – 2007. – Vol. 93. – P. 1137–1146.
5. Nemeth E., Rivera S., Gabayan V. et al. IL-6 mediates hypoferrremia in inflammation by inducing the synthesis of the iron regulatory hormone hepcidin // *J Clin Invest.* – 2004. – Vol. 113 (9). – P. 1271–6.
6. Silverberg D. S. The effect of correction of mild anemia in severe, resistant congestive heart failure using subcutaneous erythropoietin and intravenous iron: randomized controlled study [Text] / D. S. Silverberg, D. Wexler, D. Sheps // *J. Am. Coll. Cardiol.* – 2001. – Vol. 37. – P. 1775–1780.
7. Van der Putten K., Jie K. E, van den Broek D. et al. Hepcidin-25 is a marker of the response rather than resistance to exogenous erythropoietin in chronic kidney disease chronic heart failure patients // *Eur J Heart Fail.* – 2010. – Vol. 12 (9). – P. 943–50.

*Tukhtaev Nodirbek Kadirovich,
senior researcher, Ph D., in medicine,
E-mail: histo_kodir@mail.ru*

*Zokirova Nargiza Bakhodirovna,
senior researcher, DSc., in medicine(MD),*

*Tulemetov Sabirjan Khalikovich,
senior researcher, Ph D., in medicine,*

*Tukhtaev Kadir Rakhimovich,
DSc., in medicine(MD), professor,
Tashkent Medical Academy, Uzbekistan*

THE MECHANISMS OF THE TOXIC EFFECT OF INTRAUTERINE AND EARLY POSTNATAL EXPOSURE TO PESTICIDES ON THE DEVELOPMENT OF THE IMMUNE SYSTEM OF OFFSPRING

Abstract: The aim of the study was to identify the mechanisms of the toxic effect of intrauterine and early postnatal exposure to pesticides on the development of the immune system of offspring. Experiments were performed on white adult female rats, which are obtained respectively pesticides-cyhalothrin or fipronil during the pregnancy and lactation periods. The offspring from experimental and control animals have been studied on days 3, 7, 14, 21 and 30 days after birth using morphology, electron microscopy, immunohistochemistry and biochemistry methods. It was shown, that the toxic effect of pesticide exposure through the maternal organism during pregnancy and lactation is manifested in the form of a violation of the growth and formation of the thymus, as well as thymus-dependent zones of the peripheral organs of the immune system. In the mechanism of immunotoxic effect of pesticides a leading role plays the imbalance between proliferation and cells apoptosis of the thymus, caused both by direct toxic effects of drugs, and by the development of hypothyroidism and oxidative stress.

Keywords: pesticides; developmental immunotoxicity; postnatal ontogenesis; thymus; immune system; apoptosis; cells proliferation.

Introduction. The immune system, along with the endocrine and nervous systems, is extremely sensitive to the effects of various environmental pollutants. Pesticides are one of the most common pollutants of the environment. Widespread use of pesticides in agriculture, in everyday life and public health causes their entry into the human body and animals. Adverse effects of pesticides on the immune system are defined as immunotoxicity, which implies the violation of certain functions of the immune system under the influence of a toxic substance [1]. However, the immunotoxic effect of pesticides is not limited to the direct exposure of toxic substances to immune cells, causing their death and immunosuppres-

sion. In a number of cases, pesticides cause a number of metabolic changes and are inducers of the development of autoimmune reactions and abnormal hypersensitivity of the organism [2; 3]. The mechanism of immunotoxic effects of pesticides is complex and diverse. It is shown that many pyrethroid pesticides lead to a decrease in the concentration of immunoglobulins, interleukins and interferon [7; 8]. Of particular interest is the developmental immunotoxicity, when pesticides or other environmental toxicants have an adverse effect on the developing immune system of the fetus or newborn. It is known that the fetus and newborns are particularly sensitive to the action of various environmental toxicants.

In experiments with zebrafish (*Danio rerio*) embryos, pyrethroid pesticide cypermethrin has been shown to cause immune disorders as a result of the induction of apoptosis of cells [5]. Another pesticide, carbendazim, also induced cell apoptosis and caused immune and endocrine disorders in zebrafish (*Danio rerio*) in embryo development stage [4]. Mechanisms of developmental immunotoxicity of pesticides, especially in mammals and humans, are diverse and remain unclear. In our previous studies it has been shown that many modern pesticides in rats through the organism of a pregnant mother can have a negative effect on the development of the fetus and the newborn [9; 10]. A pesticide from the pyrethroid class of lambda-cyhalothrin and an insecticide from the class of benzopyrazoles fipronil had an endocrine-disrupting action in the form of hypothyroidism in the mother and offspring [11; 12]. The same animals showed oxidative stress in the form of an increase in the degree of free radical oxidation, as well as a pronounced induction of apoptosis of cells in the organs of offspring [9; 10; 13; 14]. All this served as the basis for further studies of the mechanisms of immunotoxicity of development in the immune system of offspring.

The aim of the study was to identify the mechanisms of the toxic effect of intrauterine and early postnatal exposure to pesticides on the development of the immune system of offspring.

Material and methods. Experiments were performed on nulliparous, white adult female rats, which were divided into 3 groups of 30 animals each. Two groups of animals for 30 days daily *per os* obtained respectively pesticides lambda-cyhalothrin (LCT, 8 mg/ g), or fipronil (FPN, 3.6 mg / kg). The third group receiving only the same volume of sterile saline served as a control. The following day, the females were coupled to healthy males for fertilization. Pregnancy was monitored for the presence of sperm in vaginal smears. Exposure of pesticides was continued incessantly during pregnancy and after delivery until the end of lactation. Offspring obtained from the experimental and control females were studied in dynamics on days 7, 14, 21 and 30 after birth. Thymus (Th), spleen (Sp), mesenteric lymph nodes (Mln) and thyroid gland (Tg) were studied by morphometric and electron microscopic techniques. For immunohistochemical studies of proliferation and apoptotic cells paraffin sections of thymus and thyroid

gland have been used [13]. Apoptotic cells were detected using a rabbit monoclonal antibody to fragments of caspase-3 proteins and the family of p-53 (manufactured by Thermo Scientific, USA). Proliferation cells have been detected using a rabbit monoclonal antibody to protein Ki-67 (manufactured by Thermo Scientific, USA). Further the numbers of labeled proliferating, and apoptotic cells counted on 1000–5000 total cells and calculated an index of proliferation and apoptosis, that is expressed in parts per thousand. Furthermore, in the blood serum of offspring was determined level of thyroxine (T_4), triiodothyronine (T_3), thyroid stimulating hormone (TSH) of pituitary. Besides, biochemical determination of the status of lipid peroxidation and antioxidant enzyme levels in the liver tissue were carried out [9; 10]. All digital data were processed by the method of variation statistics. Statistical significance between control and experimental groups was compared using the Student's test and P values < 0.05 were considered significant.

Results and discussion. Morphometric studies have shown that exposure to pesticides through the maternal organism significantly slows the rate of postnatal growth and the formation of the immune system of offspring. Thus, the growth rate of the thymus lobule area under the influence of LCT by 10–15%, and when FPN is applied, it is 15–30% lagging behind the control parameters ($P_1, P_2 < 0.05$). The area occupied by the cortical zone of the thymus decreased by 15–25% and 20–40%, accordingly. In the lymph nodes and spleen, a marked lag in the formation of thymus-dependent zones (T-zones) of organs was noted. Electron microscopy in the thymus showed a marked decrease in the secretory activity of epithelio-reticular cells. And, on the contrary, especially in the cortical zone of the thymus, high functional activity of macrophages was noted. In their cytoplasm, numerous heterophagosomes with remnants of destroyed thymocytes were found. All this indicated that exposure to pesticides in the embryonic and early postembryonic periods had an immunotoxic effect on the development of the immune system of the offspring. The toxic effect is manifested in the slowing of the growth and formation of the thymus, a decrease in the secretory activity of the epithelio-reticular cells, and the intensification of destruction and death of thymocytes within the thymus. As a result of violation of the regulatory function of the thymus, in the peripheral organs of the immune system

(Sp, Mln), the formation of T-zones of these organs is slowed down.

Our morphometric studies have shown various disturbances in the dynamics of growth and formation of the thyroid gland of offspring under the influence of pesticides. The growth rate of the total area of the epithelium of the follicles under the influence of LCT by 10–17%, and with the action of FPN, 15–30% lag behind the control parameters ($P_1, P_2 < 0.05$). Accordingly, the area occupied by the colloid decreased by 15–25% and 20–40%. The slowing down of the growth rate and the formation of the structural and functional unit of the thyroid gland – follicle, is most pronounced when exposed to FPN, compared with the action of LCT. However, the negative effect of pesticides was not limited only to inhibition of follicle formation. It was found that the effect of pesticides leads to a decrease in the area of the follicle as a whole due to a decrease in the areas of the epithelium of the follicle and thyrocyte. The growth rate of the height and the average area of the thyrocyte when exposed to LCT by 10–20%, and when exposed to FPN – by 15–30% lagged behind the control parameters ($P_1, P_2 < 0.05$). The slowing of growth and formation of the thyroid gland was accompanied by a significant decrease in the functional activity of the organ. Despite the high levels of thyroid-stimulating hormone (TSH), the concentration of thyroxine (T_4), triiodothyronine (T_3) remained significantly lower compared to the control. Moreover, the most pronounced hypothyroidism was observed in offspring under the influence of FPN in comparison with LCT.

The effect of pesticides led to inhibition of the proliferative activity of cells of both thymus and thyroid gland. On the 7th day after birth, the index of thymus cells proliferation under the action of LCT in 1.5 times, and when exposed to FPN 1.8 times decreased in comparison with the control ($P < 0.05$). A similar decrease in the proliferation index was found in the thyroid gland. A significant decrease in the cell proliferation index in both organs persisted up to 21 days after birth. Thus, exposure to pesticides led to inhibition of proliferative activity of cells in both the immune and endocrine organs of the offspring. In this case, the negative effect of FPN was more pronounced in comparison with LCT. Data of a different nature were obtained when calculating the apoptosis

index of cells in the thymus and thyroid gland. Intrauterine and early postnatal exposure to pesticides led to a significant increase in the degree of apoptosis of cells of the thyroid gland and thymus. In the thyroid gland of the offspring, under the influence of LCT, the apoptosis index was 3.5–4 times, and when FPN was 4.5–5 times higher than the control group in all periods of the study ($P < 0.05$). A similar significant increase in the apoptosis index at all times of the study was observed in the thymus of the experimental animals. Thus, exposure to pesticides led to a significant increase in the degree of apoptosis of cells of both the thyroid gland and thymus.

The obtained data show that the toxic effect of pesticides on the development of the immune system of the offspring (the developmental immunotoxicity) is due to a number of metabolic changes in organs and tissues. First of all, it is endocrine-disrupting, more precisely, thyroid-disrupting effect of pesticides, which leads to hypothyroidism in the mother and offspring [11; 12; 14]. Further, it is necessary to emphasize the role of oxidative stress, as the main inducer of apoptosis of cells [9; 10; 13]. Recent data show that thyroid hormones also have a high anti-apoptotic effect, which opens great prospects for the regulation of apoptosis in various diseases [6]. All this makes it possible to consider that the intensity of induction of apoptosis in our experiments is to a certain extent determined by the degree of thyroid dysfunction and the weakening of the proliferation-stimulating and anti-apoptotic effects of its hormones. Consequently, the induction of apoptosis in the experimental progeny is caused not only by the direct toxic effect of pesticides, but also largely mediated by the weakening of the anti-apoptotic function of thyroid hormones due to hypothyroidism and the resulting oxidative stress in the form of an increase in the number of free radicals.

Conclusions:

1. The toxic effect of pesticide exposure through the maternal organism during pregnancy and lactation is manifested in the form of a violation of the growth and formation of the thymus, as well as thymus-dependent zones of the peripheral organs of the immune system.

2. In the mechanism of immunotoxic effect of pesticides plays a leading role the imbalance between proliferation and cells apoptosis of the thymus, caused both by direct toxic effects of drugs, and by the development of hypothyroidism and oxidative stress.

References:

1. Corsini E., Sokooti M., Galli C.L., Morettoc A., Colosio C. Pesticide induced immunotoxicity in humans: A comprehensive review of the existing evidence // *Toxicology*.– 2013.– Vol. 307.– P. 123–135.
2. Dhouib I., Jallouli M., Annabi A., Marzouki S., et al. From immunotoxicity to carcinogenicity: the effects of carbamate pesticides on the immune system // *Environ Sci Pollut Res Int*.– 2016.– Vol. 23.– P. 9448–9458.
3. Fukuyama T., Kosaka T., Tajima Y., Ueda H., et al. Prior exposure to organophosphorus and organochlorine pesticides increases the allergic potential of environmental chemical allergens in a local lymph node assay // *Toxicol. Lett*.– 2010.– Vol. 199.– P. 347–356.
4. Jiang J. Wu Wu S., An C., Cai X., Zhao L. X. Embryonic exposure to carbendazim induces the transcription of genes related to apoptosis, immunotoxicity and endocrine disruption in zebrafish (*Danio rerio*) // *Fish Shellfish Immunol*.– 2014.– Vol. 41.– P. 493–500.
5. Jin Y., Zheng S., Fu Z. Embryonic exposure to cypermethrin induces apoptosis and immunotoxicity in zebrafish (*Danio rerio*) // *Fish Shellfish Immunol*.– 2011.– Vol. 30.– P. 1049–1054.
6. Lin H. Y., Glinesky G. V., Mousa S. A., Davis P. J. Thyroid hormone and anti-apoptosis in tumor cells // *Oncotarget*.– 2015.– 6(17).– P. 14735–14743.
7. Mokarizadeh A., Faryabi M. R., Rezvanfar M. A., Abdollahi M. A comprehensive review of pesticides and the immune dysregulation: mechanisms, evidence and consequences // *Toxicol Mech Methods*.–2015.– Vol. 25.– P. 258–278.
8. Skolarczyk J., Pekar J., Nieradko–Iwanicka B. Immune disorders induced by exposure to pyrethroid insecticides // *Postepy Hig Med Dosw*.– 2017.– Vol. 8.– P. 446–453.
9. Tukhtaev K. R., Tulemetov S. K., Zokirova N. B., Tukhtaev N. K. Effect of long term exposure low doses of lambda-cyhalothrin on the level of lipid peroxidation and antioxidant enzymes of the pregnant rats and their offspring // *Medical and Health Science Journal*.– 2012.– Vol. 13.– P. 93–98. URL: <http://www.pradec.en>
10. Tukhtaev K. R., Tulemetov S. K., Zokirova N. B., Tukhtaev N. K. et al. Prolonged exposure of low doses of Fipronil causes oxidative stress in pregnant rats and their offspring // *The Internet Journal of Toxicology*.– 2013.– Vol. 10.– No. 1. URL: <http://www.ispub.com/IJTO/10/1/14550>
11. Tukhtaev K. R., Zokirova N. B., Tulemetov S. K., Tukhtaev N. K. Effect of prolonged exposure of low doses of lambda-cyhalothrin on the thyroid function of the pregnant rats and their offspring // *Medical and Health Science Journal* – 2012.– Vol. 13.– P. 86–92. URL: <http://www.pradec.en>
12. Tukhtaev K. R., Zokirova N. B., Tulemetov S. K., Tukhtaev N. K. et al. Effect of Prolonged exposure low doses of Fipronil on thyroid function of pregnant rats and their offspring // *The Internet Journal of Toxicology*.– 2013.– Vol. 10.–No. 1. URL: <http://www.ispub.com/IJTO/10/1/14549>
13. Tukhtaev N. K., Zokirova N. B. The influence of in utero and early postnatal exposure to pesticides on the process of cells apoptosis and proliferation in immune and endocrine organs of the offspring // *European Science Review – Austria, – Vienna, – 2017. – No. 3–4. – P. 57–58.*
14. Zokirova N. B. Morphological and functional features of thyroid gland of posterity under in utero and early postnatal exposure to pesticides // *European Science Review. – Austria, – Vienna, – 2017. – No. 3–4. – P. 33–34.*

*Usmanova Shakhnoza Erkinovna,
Independent researcher of Tashkent Medical Academy,
Republic of Uzbekistan
Yakubov Abdusalol Vahabovich,
Head of the department of Clinical Pharmacology
of Tashkent Medical Academy, Republic of Uzbekistan
Hamraev Abror Asrarovich,
professor, of the department of Internal Medicine № 2
of Tashkent Medical Academy Republic of Uzbekistan
E-mail: evovision@bk.ru*

STATE OF COLLAGEN SYNTHESIS IN GASTRIC MUCOSA AND RENAL TISSUE IN INDOMETACIN GASTROPATHY IN ANIMALS WITH EXPERIMENTAL RHEUMATOID ARTHRITIS

Abstract: Production and release of aldosterone, proximal canalicular re-absorption of sodium, shortening of afferent and efferent arterioles, heightened saline appetite, inhibition of parasympathetic nervous system, stimulation of β -adrenoreceptors, intensification of proteinuria – it is not complete list of effects provoked by angiotensin II. Mechanisms considered prove involvement of both glomerular and tubular-interstitial apparatus in damage of kidneys by indometacin.

Keywords: Collagen, indometacin gastropathy, rheumatoid arthritis.

It was established that reparation of ulcer defect heals by cicatrization. Main element of cicatricial tissue is collagen having amino acid oxyproline in its structure. Results of studying the latter in biologic fluids adequately reflect process of collagen formation [1, 2]. Therefore studying structure of this amino acid in tissues it may be predetermined a state of collagen formation and regeneration processes of ulcerous-erosive disorders in mucosa of gastrointestinal tract (GIT). As regards renal tissue a content of oxyproline specifies a state of inflammation process accompanying by sclerosis of renal tissue [3, 4, 5, 6, 7].

Aim of research was to study a state of collagen synthesis in gastric mucosa and renal tissue in indometacin gastropathy in animals with experimental rheumatoid arthritis.

Materials and methods of research: Experimental studies were carried out on 21 male rats of mixed population with mass 160–200 g that were on common ration of vivarium. Animals were divided into 3 groups of 7 animals each. The 1st group was intact, the 2nd group with experimental rheumatoid arthritis (ERA), the 3rd group – animals with ERA and indometacin gastropathy (GERA).

Experimental model of rheumatoid arthritis was reproduced by a single administration of 0.2 ml Freund's adjuvant into posterior right leg of animal [8]. Indometacin induced gastro- and nephropathies were produced by administration of indometacin per os as water suspension at a dose 2.5 mg/kg during 5 days [9]. All painful procedures were performed in accordance with the WMA Declaration of Helsinki. To perform biochemical studies all the animals were single-stage decapitated under etherization. Stomach was extracted, then purified, washed with a cold physiological solution, proventriculus was removed. Mucous layer then was scarified, weighed and slurried in distilled water at a rate 30 mg/ml.

Kidneys were crushed and homogenized in a glass homogenizer with Teflon pestle in 3–4-fold volume of excretion medium consisting of 0.25M saccharose, 0.05M KCl in 0,05M solution tris HCl buffer (pH 7.4). To precipitate nuclei, mitochondria and disordered cells homogenates were centrifuged in 9000 g during 20 minutes. Content of oxyproline in supernatant fraction of homogenate was determined by a method of A. Steven and co-authors [10].

Results obtained were treated with using of Student's t-criterion by a statistically standard package of Microsoft Excel. Differences considered valuable in $p < 0.05$.

Results and their discussion: Results of studying a content of oxyproline in gastric and renal tissue are given in the table.

Table 1. – Content of oxyproline in gastric mucosa and renal tissue in indometacin gastropathy in animals with experimental rheumatoid arthritis

Group of animals	Oxyproline. nmol/mg		P
	Stomach	kidneys	
Control	2.12 ± 0.077	5.28 ± 0.180	< 0.001
ERA	1.95 ± 0.062	7.16 ± 0.315	< 0.001
GERA	0.44 ± 0.019	14.51 ± 0.384	< 0.001

Note: p – reliability from indices of control group.

How it is seen from the presented data a content of oxyproline in gastric mucosa in ERA is practically not differed from control group, whereas it is reliably increased 35.6% from index of control group. Reduction in content of oxyproline noted to be in gastric mucosa 79.3% from control group in using of indometacin (GERA). Content of oxyproline in renal tissue was increasing 174.8% in this group. Probably, suppression of regeneration processes by indometacin in gastric mucosa was caused by abnormalities in functioning of numerous inter-caused cytoprotective factors that leads to lowering of post-epithelial factors of protection, which principal element are «cytoprotective» prostaglandins. It is established that prostaglandin E_2 implements its protective potential on suppression of formation of gastric acid, increase of mucus and bicarbonate secretion, stimulation of regeneration.

Unlike to stomach a considerable increase of oxyproline in application of indometacin observed to be in kidneys. It is likely to be caused by some inter-related mechanisms. Block of synthesis of renal prostaglandins by indometacin increases and prolongs vasoconstrictive action of angiotensin II playing a key role in progressive lowering of renal function by means of hemodynamic

and «non hemodynamic» mechanisms [11, 12]. Renin-angiotensin-aldosterone system actuates when release of renin by juxtaglomerular cells of kidneys occurs. The latter catalyzes transformation of angiotensin in angiotensin I in the liver. Then locally in tissues occurs transformation of angiotensin I in angiotensin II (active form) – under participation of angiotensin I converting enzyme. Production and release of aldosterone, proximal canalicular re-absorption of sodium, shortening of afferent and efferent arterioles, heightened saline appetite, inhibition of parasympathetic nervous system, stimulation of β -adrenoreceptors, intensification of proteinuria – it is not complete list of effects provoked by angiotensin II. Mechanisms considered prove involvement of both glomerular and tubular-interstitial apparatus in damage of kidneys by indometacin.

Conclusions:

1. Indometacin considerably reduces a content of oxyproline in gastric mucosa that confirmed suppression of regeneration processes.
2. Preparation increases a content of oxyproline in renal tissues in indometacin gastropathy that exhibited appearance of inflammation process leading to renal tissue sclerosis.

References:

1. Mazurov V.I. Biochemistry of collagen proteins. – M., – 1974. – 220 p.
2. Osadchuk T. K., Motin Yu. K., Osadchuk M. A. Study of oxyproline in gastric juice and its diagnostic value // Laboratory work. – 1982. – No. 4. – P. 16–18.
3. Akbarova D. S., Khamraev A. A. Estimation of effectiveness of combination of omeprazole, clarithromycin and metronidazol on a content of some amino acids in gastric mucosa // Days of young researchers: materials of scientific practical conference of postgraduate students, applicants and reviewers. – Tashkent, – 2005. – P. 5–6.
4. Dyagteva I. I. Disorders of protein metabolism in ulcer disease // Clin. Medicine. – 1979. – V. 57. – No. 6. – P. 31–38.
5. Arisawa T., Nakazawa S., Segawa K. Fluctuation of the mucosal hydroxyproline content in compound 48/80 induced gastric lesions in rats // Scand. J. Gastroenterol. – 1989. – Vol. 24. – No. 162. – P. 27–30.

6. Rybachkov V.V., Dryashenkov U. G. Complicated gastroduodenal ulcers // Surgery. N.I. Pirogov Journal.– 2005.– No. 3.– P. 27–29.
7. Moskalev A. V., Rudoy A. S. Exchange of cytokins and free oxyproline of blood serum in patients with erosive–ulcerous diseases of gastroduodenal area with a non differentiated dysplasia of connective tissue // Herald of the Russian Military Medical Academy.– 2006.– No. 2. (16).– P. 64–68.
8. Experimental rheumatoid arthritis / Sinyachenko O. V., Barinov E. F., Zyablitsev S. V. et al. // Rheumatology.–1991.– No. 3.– P. 36–40.
9. Meshishen I. F., Vasilyev S. V. Effect of indometacin and voltaren on oxidation and restoration of glutathione in the liver of white rats // Phatmacology & Toxicology.– 1985.– No. 1.– P. 28–30.
10. Steven A. Amino Acid Analysis utilizing Fhengliso – tiocyanata Derivatives / A. Steven, D.J. Cohen // Analyt. Biochem.– 1988.– Vol. 17.– No. 1.– P. 11–16.
11. Yesayan A. M. Tissue renin angiotensin system of the kidney. New strategy of renoprotection // Nephrology.– 2002.– Volume 6.– No. 3.– P. 10–14.
12. Henrich W. L. Nefrotoxicity of non–steroidal anti–inflammatory agents. In Schrier R., Gottshalk C., Eds. Diseases of the kidney (5th edn.) // Boston: Little Brown.– 1992.– P. 1201–1218.

Khabibullayev B. B.,
Batyrbekov A. A.
Republican Scientific Center
of Immunology of the Ministry of Health
of the Republic of Uzbekistan, Tashkent
E-mail: shga2065@yandex.ru

THE INFLUENCE OF HARMALA AND KARELINIA CASPIA ON THE IMMUNE STATUS FOR RAY DISEASE IN EXPERIMENT

Abstract: It was established, that Harmala and Karelinia caspia possess ability increase immune response to sheep erythrocytes and titer antierythrocytes antibodies in peripheral blood, stimulated proliferation cells in central (thymus, bone marrow) and peripheral (lymph nodes) organs of immunity of mice radiation sickness.

Keywords: Harmala, Karelinia caspia, radial illness, immune response, organs of immunity, erythrocytes, leukocytes.

Currently, plants attract the close attention of researchers as a source of obtaining biologically active drugs with different vectors of effects on the body. A rich source of obtaining herbal medicines is the Central Asian region [9]. Herbal preparations are used for many somatic [2, 4], oncological diseases [5, 7], liver diseases [6], with radiation effects [3, 8]. Many plants have hypoglycemic activity [1].

The aim of the work is to study the influence of the hypoglycemic plant-based means (*Peganum harmala*) and *Karelinia caspia* (*Karelinia caspia*) on immunogenesis in radiation sickness.

Material and methods

In the experiments, white mongrel mice of 2–3 months of age weighing 20–22 g were used. For modeling radiation sickness (RS), mice were irradiated in total at a dose of 5 Gy. After 5 days, they were intraperitoneally immunized with sheep red blood cells (SRBC) at a dose of 2×10^8

and after 5 days the number of antibody-producing cells (ABPC) of spleen was determined [10]. There also were determined the titer of antibodies to SRBC in the blood, the number of cells in the thymus, in the bone marrow, in the mesenteric lymph nodes, the number of erythrocytes and leukocytes in the peripheral blood of mice.

Results and discussion

The results of studies on the effect of harmala and *Karelinia caspia* on immunological reactivity in mice with RS are given in Table 1. As can be seen from this table, in the spleen of the mice of the control group an average of 7756.3 ± 366.4 antibody-producing cells are formed, and in animals with RS in 10, 3 times less. Consequently, after the radiation exposure, a deep secondary immunodeficiency is formed. It is established that all the studied herbal remedies have the ability to correct to a certain extent violations in the immune status in irradiated mice.

Table 1. – Effect of Harmala and Karelinia caspia on the immune response to sheep red blood cells in mice with radiation sickness (RS) ($M \pm m$)

Group	Dose. mg/ kg	Number of NCS $\times 10^6$	IR	The number of ABPC at			
				whole spleen	IR	10^6 cells of the spleen	IR
1	2	3	4	5	6	7	8
1. control (n = 8)	–	163.6 ± 3.9	–	7756.3 ± 366.4	–	47.6 ± 2.6	–
2. RS (n = 8)	–	39.9 ± 0.9^a	–4.10	756.3 ± 32.0^a	–10.3	19.0 ± 1.0^a	–2.51

1	2	3	4	5	6	7	8
3. RS + Harmala (n = 8)	50.0	71.8 ± 1.7 ^{ab}	+1.80	2681.3 ± 113.8 ^{ab}	+3.55	37.5 ± 1.9 ^{ab}	+ 1.97
4. RS + KC (n = 8)	100.0	59.9 ± 1.4 ^{abc}	+1.50	2206.3 ± 89.4 ^{abc}	+2.92	37.0 ± 1.8 ^{ab}	+ 1.95
5. RS + KC + veh. (filler) (n = 8)	100.0	63.9 ± 1.5 ^{abc}	+1.60	2431.3 ± 102.6 ^{ab}	+ 3.21	38.2 ± 2.0 ^{ab}	+ 2.01

Note: here and in the following tables, KC is *Karelinia caspia*, KC + veh. (filler). – *Karelinia caspia* with vehicle (filler), NCS – nucleated cells of the spleen; ABPC – antibody-producing cells; IR – the index of the ratio: (–) – in relation to 1 gr, (+) – in relation to 2 gr, A – authentically to 1 gr, B – authentically to 2g, C – authentically to 3g.

In mice receiving Harmala diet, 2,681.3 ± 113.8 ABPC are formed in the spleen, which is significantly 3.55 times higher than in the immunodeficiency group. In animals with RS who received *Karelinia caspia*, the immune response to sheep blood cells is 2.92 times higher than in untreated mice. Immunostimulating activity of Harmala is significantly higher than in *Karelinia caspia*. *Karelinia Caspian* with a filling of 3.21 times increases the depressed number of ABPC in mice with RS. Thus, the studied herbal remedies have the ability to some extent to increase the immune response to SRBC in irradiated animals. When calculating AOC for 1 million spleen cells, the following results were obtained. In the control group, this indicator is 47.6 ± 2.6 ABPC, and in mice with RS – 2.51 times less.

Under the influence of Harmala, this indicator is 1.97 times higher compared to the untreated group, the *Karelinia caspia* – by 1.95 times, the *Karelinia caspia* with vehicle (filler) – by 2.01 times. There is no significant difference between the indicators. Thus, when calculating the ABPC for both the whole spleen and 1 million sple-

nocytes, the ability of the studied herbal remedies to significantly enhance immunological reactivity in mice after radiation exposure was established. As can be seen from Table 1, the total number of NCS in the control is 163.6 ± ± 3.9 '10⁶, and after the radiation exposure, this index decreases by 4.10 times. When the Harmala is administered, the total number of splenocytes in mice with RS significantly increases in comparison with the untreated group by 1.80 times. With the introduction of *Karelinia caspia*, the number of NCS in irradiated mice increases 1.50 times. In the group receiving *Karelinia caspia* with vehicle (filler), the number of splenocytes increases by 1.60 times. The stimulating activity of harmal is significantly higher than in *Karelinia caspia* without and with a reservoir. Thus, the studied herbal remedies have the ability to increase the immunological reactivity of the organism and the total number of NCS in mice with RS.

Further we investigated the effect of herbal remedies for antibody titer to SRBC in the peripheral blood of mice with RS (Table 2).

Table 2. – Influence of Harmala and *Karelinia caspia* on the titer of antibodies to erythrocytes of the sheep in the blood of mice with radiation sickness (RS) (M ± m)

Group	Dose. mg / kg	Titer of antibodies to SRBC (log ₂)	IR
1. control (n = 8)	–	5.4 ±	–
2. RS (n = 8)	–	2.0 ±	–2.70
3. RS + Harmala (n = 8)	50.0	2.8 ±	+1.40
4. RS + KC (n = 8)	100.0	2.5 ±	+1.25
5. RS + KC + veh (filler) (n = 8)	100.0	2.6 ±	+1.30

On the 4th day after immunization, the antibody titer to SRBC in the control group is 5.4 ± 0.2, and in irradiated mice is 2.70 times less (p < 0.05). When administered to mice with RS Harmala, the titer of antibodies

to SRBC in the blood is significantly increased by 1.40 times in comparison with the previous group. *Karelinia caspia* without vehicle (filler) increases the antibody titer to SRBC by 1.25 times, and with the vehicle (filler) – by

1.30 times. However, in both cases, the difference with the irradiated and untreated group proved to be unreliable. Consequently, only under the influence of Harmala there is a significant increase in the titer of antibodies to SRBC in mice with RS.

Next, we studied the effect of herbal remedies in the state central and peripheral organs of immunity system in mice with RS. The results of these studies are presented in (Table 3).

Table 3. – The Effect of Harmala and Karelinia caspia on the number of cells in immunity organs in mice with radiation sickness (RS) ($M \pm m$)

Group	Dose, mg/kg	Thymus' cells $\times 10^6$ Cell	IR	Bone marrow cells	IR	Lymph nodes cells $\times 10^6$	IR
1. control (n = 8)	–	39.4 \pm	–	12.7 \pm	–	25.3 \pm	–
2. RS (n = 8)	–	12.7 \pm	-3.10	4.5 \pm	-2.82	9.4 \pm	-2.72
3. RS + Harmala (n = 8)	50.0	17.1 \pm	+1.35	6.2 \pm	+1.38	12.1 \pm	+1.29
4. RS + KC (n = 8)	100.0	16.2 \pm	+1.28	5.7 \pm	+1.27	11.0 \pm	+1.17
5. RS + KC + veh. (filler)(n = 8)	100.0	16.7 \pm	+1.32	5.9 \pm	+1.31	11.5 \pm	+1.22

As can be seen, the total number of cells in the thymus of the control group mice is $39.4 \pm 1.7 \times 10^6$, and in animals with RS it is 3.10 times smaller. When irradiated mice of harmala, Karelinia caspia with vehicle (filler) are injected, the number of cells in the thymus significantly increases 1.35 times, 1.28 times and 1.32 times, respectively. The stimulating activity of the studied samples does not differ significantly from each other. Consequently, all studied plant products are able to increase the number of cells in the thymus in mice with RS. The total number of cells in the bone marrow in irradiated mice is reduced by 2.82 times. Under the influence of Harmala, the number of cells in the bone marrow increases significantly by 1.38 times. In irradiated mice that received Karelinia caspia, the number of bone marrow cells significantly increased by 1.27 times in comparison with the untreated group.

The stimulating activity of the Karelinia caspia is significantly lower than in the harmaly. In the group of mice with RS, who received Karelinia caspia with vehicle (filler), the number of cells in the bone marrow increases by 1.31 times ($p < 0.05$), and this level does not differ significantly from the data obtained in animals receiving Harmala. Thus, one can draw a conclusion about the ability of the studied agents to stimulate the proliferation of cells in the central (thymus, bone marrow) immunity organs in irradiated animals.

Next, the effect of plant remedies on the total number of cells in the peripheral organs of immunity (mesenteric lymph nodes) was studied in mice with RS (Table 3). In the control group, the number of cells in the lymph nodes is $25.3 \pm 0.8 \times 10^6$, and in irradiated mice is 2.72 times less. All studied herbal remedies significantly increase the number of cells in lymph nodes in mice with RS: harmala – 1.29 times, Karelinia caspia – 1.17 times Karelinia caspia with filler – 1.22 times. By stimulating activity, the studied samples do not differ significantly from each other. Thus, all the studied herbal remedies have the ability to increase the number of cells in the central and peripheral organs of immunity in irradiated animals.

The results of studies on the evaluation of the effect of herbal remedies on hematologic indices are given in Table 4. In the control group, the number of red blood cells is $4.7 \pm 0.1 \times 10^9 / \text{ml}$, and in irradiated mice is 2.76 times less. In irradiated mice receiving Harmala, the number of erythrocytes in the blood increases significantly by 1.24 times. Under the influence of Karelinia caspia, the number of erythrocytes increases by 1.12 times ($p < 0.05$). The stimulating activity of harmal is significantly higher than that of Karelinia caspia. Addition of vehicle (filler) to Karelinia caspia increases its stimulating properties: the number of erythrocytes increases by 1.18 times. Consequently, the studied herbal remedies can in-

crease the number of erythrocytes in peripheral blood in animals with RS.

The number of blood leukocytes in irradiated mice is reduced by 2.88 times. The studied herbal remedies have

the ability to reliably increase the number of leukocytes in the blood of irradiated mice.

Table 4. – The Influence of Harmala and Karelina caspia on the number of red blood cells and leukocytes in peripheral blood in mice with radiation sickness (RS) ($M \pm m$)

Group	Dose. mg/kg	Erythrocytes $\times 10^9$ /ml	IR	Leukocytes $\times 10^6$ /ml	IR
1. control (n = 8)	–	4.7 \pm	–	6.9 \pm	–
2. RS (n = 8)	–	1.7 \pm	–2.76	2.4 \pm	–2.88
3. RS + Harmala (n = 8)	50.0	2.1 \pm	+1.24	3.0 \pm	+1.25
4. RS + KC (n = 8)	100.0	1.9 \pm	+1.12	2.8 \pm	+1.17
5. RS + KC + veh. (filler) (n = 8)	100.0	2.0 \pm	+1.18	2.9 \pm	+1.21

Under the influence of Harmala, the number of leukocytes increases by 1.25 times ($p < 0.05$) and Karelina caspia with vehicle (filler) – by 1.21 times ($p < 0.05$).

The stimulating activity of Harmala is significantly higher than that of Karelina caspia.

References:

1. Azizov U. M., Abidov A. A., Aliev Kh. U. Hypoglycemic activity and acute toxicity of dry extracts of hips, bean leaves, walnut leaves, nettle leaves, yarrow herb // Mat. Of science.-practical. Conf. "Integration of education, science and production in the formation". – Tashkent, – 2010. – P. 331–332.
2. Gorbacheva A. V., Aksinenko S. G., Zelenskaya K. L. Anti-inflammatory properties of a number of herbal preparations // Bulletin of the Siberian Branch of the Russian Academy of Medical Sciences. – 2003. – No. 1 – P. 12–15.
3. Rasina L. N., Larionov L. P., Lyubashevsky N. M. Study of phytopreparations as a means of pharmacological correction of radiation effects // Pharmacy. – 2003. – No. 1. – P. 30–32.
4. Turischev S. N. Medicinal plants – regulators of bowel function // Pharmacy. – 2002. – No. 3. – P. 47–48.
5. Chaadaeva A. V., Tepkeeva I. I., Moiseeva Ye. V. Antitumor activity of peptide extract of medicinal plants PE-PM on a new mouse model of T-lymphocytic leukemia // Biomedical chemistry. – 2009. – V.55. – No. 1. – P. 81–88.
6. Chuchalin V. S., Teplyakova E. M. Correction of pathologies of hepatobiliary system with complex herbal remedy // Bulletin of Siberian Medicine – 2007. – V. 6. – No. 4. – P. 52–57.
7. Sharapov Sh. M., Yunusova Kh. M., Rakhimova G. K. Development of a drug for the treatment of the prostate and prostate adenoma // Mat. scientific-practical. Conf. "Integration of education, science and production in the formation." – Tashkent, – 2010. – P. 286–287.
8. Shakhmurova G. A. Influence of phytoecdysteroids on immunogenesis in radiation sickness // Uzbek biological journal. – 2005. – No. 1. – P. 3–5.
9. Yuldashev A. S. Medicinal plants of the South-Turkestan and North-Zarafshansky ranges: Abstract. dis. ...doc. Biol. sciences. – Tashkent. – 2001. – 49 p.
10. Jerne N. K., Nordin A. A. Plaque formation in agar by a single cell. – 1963. – Vol. 105. – P. 405–407.

*Khamraev Farhod Sharafovich,
The Dean of Medical and Pediatric Faculty
of the Bukhara State Medical Institute,
Bukhara, Uzbekistan
E-mail: doctorfarkhod@gmail.com*

NEUROPHYSIOLOGICAL EVALUATION OF THE EFFICIENCY OF TREATMENT OF BOTULOTOXIN OF SPASTIC FORMS OF INFANT CEREBRAL PALSY

Abstract: 75 patients with infant cerebral palsy (cerebral palsy) were treated and received treatment with a drug based on botulinum toxin-A. Patients are divided into 3 groups. The results of ENMG-examination in the 15th day and after 3 months of treatment showed with sufficient evidence that already at the first stage of the study, the use of local injections of botulinum toxin-A improves the condition of the peripheral neuromuscular device. Positive shifts are most pronounced in patients of the 1st group (with a high rehabilitation potential) and in patients of the 2nd group (who have the skills of independent walking).

Keywords: spasticity, motion, botulotoxin, correction, rehabilitation.

Very important for the treatment of patients with spastic forms of cerebral palsy is the possibility of reducing muscle hypertension, which is not an end in itself, but it helps to eliminate and significantly reduce its influence as one of the main factors in the development of contractures and achieve functional improvements in the patient [1].

Despite the fact that there is a sufficiently large number of ways to reduce muscle tone in cerebral palsy, all of them have their shortcomings, side effects, undesirable effects and many contraindications. Most of the techniques require a long-term use, at a time when the effect is kept short enough. Therefore, the search continues for new, more effective, long-term, a traumatic, having a minimum number of side effects and contraindications, methods of correction of muscle tone. In this sense, the use of local injections of botulinum toxin-A (BT-A) is very attractive [2–4].

The aim of the research was to study the effect of injections of BT-A on the indices of the functional state of the neuromotor apparatus of patients with spastic forms of infant cerebral palsy (ICP) using the methods of global and stimulation electroneuromyography (ENMG) to objectify the evaluation of treatment effectiveness.

Materials and methods. We observed 75 patients suffering ICP who received inpatient treatment at the Republican Children's Psychoneurological Hospital in Tashkent. Among the observed children there were 40

boys and 35 girls. The age of the patients ranged from 2 to 14 years, on average 8 ± 6 years.

Taking into account the late formation of the motor habits in children with ICP and the consequent narrowing of the informational space the main task for treatment for our patients is early rehabilitation of their motor sphere. The most important stage is the achievement of the vertical body position and walking capacity. Just this is the target of the most our cases (group 1–20 patients). We could not suggest that in the other part of children the course of rehabilitation resulted in acquiring of independent vertical pose and walking due to more severe retardation of psychomotor development. The purpose for use of BT-A for these children was to acquire other locomotor actions: to turn over, to sit, to creep (group 2–21 patients). Group 3 included children who received injection of BT-A in order to eliminate cosmetic defect and correction of walking (group 3–30 patients). Injection of BT-A was administered in those muscle-agonists which were key in the formation of pathological muscular synergia. The dose was independent not only on muscle size but also degree of spasticity, degree of lesion.

Results and considerations. The results of ENMG studies conducted before the treatment in all patients showed a significant difference in many parameters, in comparison with healthy children.

High levels of bioelectrical activity (BEA) of resting muscles were observed both in the upper and lower extremities. Overstrained in comparison with healthy children, BEA muscle in rest testified to a significant muscle hypertension: – biceps arm muscles – 158.95 mV (116.14% higher than in healthy children); – triceps muscles of the shoulder – 191.58 mV (by 162.03% above the norm); – anterior tibial muscle – 157.46 mV (227.9% above the norm); – gastrocnemius muscle – 122.97 mV (55.83% above the norm).

BEA rest in patients with cerebral palsy in extensors is higher than in flexors. In the examined healthy children, BEA rest in the flexor is higher than in the extensors. ENMG with an arbitrary muscle contraction in children with spastic forms of ICP was of the type of tonic tension, it was low-amplitude, high-frequency, slowly increasing at the beginning of the movement and slowly decreasing at the end. BEA in the performance of its function (with arbitrary muscle contraction) is significantly reduced compared with healthy children. According to the surface ENMG data, practically all patients had signs of a violation of supra segmental regulation of muscle tone, which manifested itself in a significant increase in the norm of the reciprocity coefficient (CR) and the adequacy coefficient (CA). The data of monosynaptic testing showed that the ratio of Nmax to Mmax, which characterizes the level of excitability of spinal neurons, before treatment was 15.81% (37.24% in healthy), which indicates a significant decrease in the total number of motor neuron motor units involved in the norm in a reflex reaction. The threshold for the ap-

pearance of the M-response in the examined patients averaged 2.25 mA (4.57 mA in healthy subjects), the threshold of the H-reflex, normalized according to the M-response – 2.08 mA (3mA in healthy), indicating weakening the influence of the pyramidal pathway on segmental motoneurons.

The results of the ENMG survey conducted by us on the 15th day after treatment showed with sufficient evidence that already at the first stage of the study, the use of local injections of BT-A improves the condition of the peripheral neuromuscular device. This was manifested in reliable positive dynamics, obtained from ENMG data. The amplitude of BEA IM in rest decreased by 34.4%, BEE PMM at rest decreased by an average of 46.9%, which was clinically manifested in a decrease in the tonus of the calf muscles.

Positive shifts are more significant not in injected muscles, but in muscle antagonists, which is apparently due to the normalization of reciprocal relationships, as evidenced by the positive dynamics of CR and SC. The CR dropped by an average of 30.9%, CA – by 30.3%. These changes in the coefficients determining the degree of regulation of the muscle tone were almost always accompanied by an increase in the amplitude of BEA in the agonist muscles. Those patients who noted these changes showed less co-contraction of the antagonists, involvement of the muscles in pathological synergies, and as a result, the function of the agonist improved, which was manifested in an increase in the amplitude of its BEA when performing an arbitrary physiological effort, but was clinically observed improvement of motor abilities of patients.

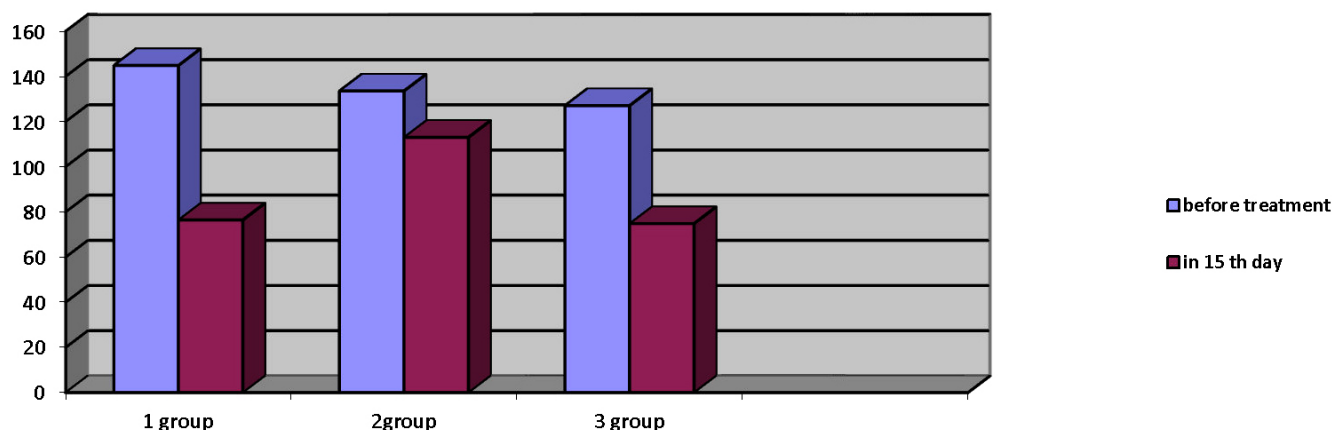

Figure 1. Change of BEA in the rest of m. gastrocnemius before and on the 15th day of treatment with BT-A

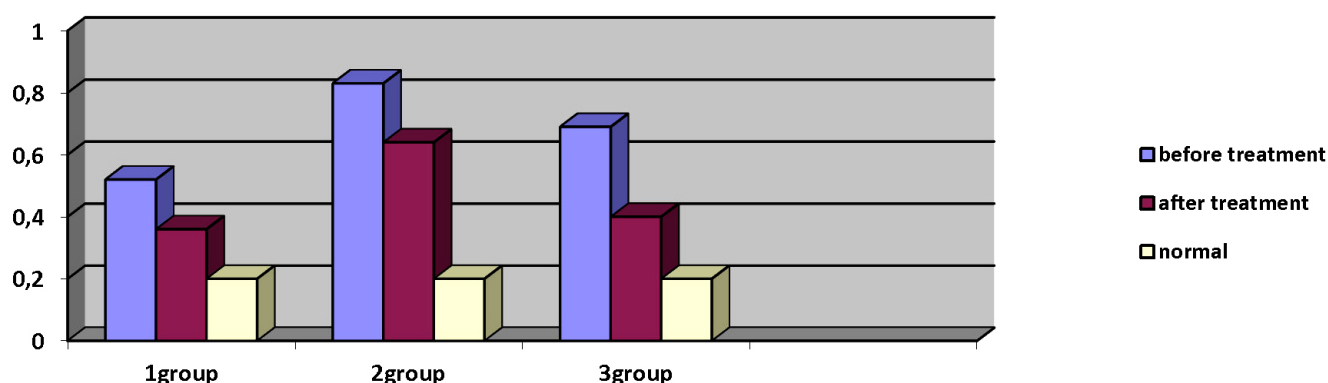

Figure 2. Change of the reciprocal coefficient parameters before and after treatment

Monosynaptic testing data showed a positive dynamics of the ratio of N_{max}/M_{max} , which characterizes the level of excitability of spinal neurons, which indicates an increase in the total number of motor neuron units involved in the reflex response. In 1 group of patients (with high rehabilitation potential), this indicator approached

the values registered in healthy children ($38.4 \pm 1.4\%$). The biggest jump of this indicator occurred in the 2nd group (patients with severe degree of lesion) – by 77.8%. In the third group of patients with independent walking skills, the N_{max}/M_{max} ratio increased by 37.6%.

Table 1. – Comparative analysis of dynamics of ENMG indices before treatment, on the 15th day and in the distant period

ENMG indicators		Before treatment	On the 15 th day	In 4–6 months
BSP	BEA in the rest	145.2 ± 13.4	$89.6 \pm 7.3^{**}$	$97.7 \pm 10.9^*$
	BEA in contraction	590.3 ± 56.0	755.9 ± 79.2	590.3 ± 31.1
Musculus gastrocnemius	BEA in the rest	135.3 ± 12.7	$88.7 \pm 8.5^*$	$91.8 \pm 11.6^*$
	BEA in contraction	423.0 ± 41.4	$591.9 \pm 45.5^*$	$583.6 \pm 57.9^*$
Reciprocal coefficient		0.65 ± 0.07	$0.45 \pm 0.04^*$	0.33
Adequacy coefficient		0.87 ± 0.02	$0.55 \pm 0.03^{***}$	0.38
N/M%		15.4 ± 3.5	20.7 ± 3.7	28.9 ± 6.0
M-response threshold		2.29 ± 0.17	2.71 ± 0.29	$4.64 \pm 0.73^{**}. a$
H-reflex threshold		2.10 ± 0.10	2.29 ± 0.18	$3.50 \pm 0.52^*. a$

Note: * – Reliable with respect to data before treatment: * – $P < 0.05$; ** – $P < 0.01$;

*** – $P < 0.001$. a – reliably with respect to data on day 15 treatment: a – $P < 0.05$

Conclusions:

1. The results of ENMG studies on the background of treatment with BT-A indicate a significant decrease in the tone of not only injected muscles but also in muscle antagonists and agonists, which is expressed in a decrease in BEA resting of the calf muscles, on average, by 36.7%.

2. As a result of treatment with local BTA injections, the arbitrary activity of the leg muscles increases due to an increase in BEA on average by 40.6% in performing its

function, which clinically manifests itself in the development of new motor skills.

3. Already on the 15th day of treatment with BTA, the reciprocal relationship between muscle antagonists improves, which is reflected in a decrease in CR and SC on average by 30.6%.

4. Positive changes are most pronounced in patients with high rehabilitation potential.

References:

1. Kozhevnikova V. T. Modern technologies in complex physical rehabilitation of patients with cerebral palsy.– Moscow,– 2005.– 238 p.
2. Klochkova O. A., Klochkova A. L., Namazova-Baranova L. S. et al. The concept of “key muscles” and the early onset of botulinotherapy with spastic forms of infantile cerebral palsy // Questions of modern pediatrics.– 2017; 16 (1): 39–48.
3. Valencia D. Colombian experiences with botulinum toxin type A in children with cerebral palsy. 5 World Congress of the International Society of physical and rehabilitation medicine. 13–17.06.2009. Istanbul.– 1252 p.
4. De Araujo I. F., Carazzato M. S., Aoki S. S. Comparison between peripheral nerve block with phenol 5% and with botulinum toxin type A on hip adductor muscles in patients with cerebral palsy // 5 World Congress of the International Society of physical and rehabilitation medicine. 13–17.06.2009. Istanbul – 1253 p.

*Husanghodjaeva Malika Tursunkhodzhaevna,
Head of the Department of Emergency Gynecology
Republican Scientific Center of Emergency
E-mail: medical center, Uzbekistan
E-mail: evovision@bk.ru*

MORPHOLOGICAL, MORPHOMETRIC CHANGES IN MOMOMATOUS NODES IN WOMEN WITH UTERINE MOMORY

Abstract: The development of proliferative processes is due not only to the increased proliferation of cells, but also to the weakening of the induction of apoptosis. With low proliferative activity (simple MM), the level of apoptotic activity is high enough. With a high activity of proliferative processes, the level of apoptosis is sharply reduced, i.e. tumor growth can be considered as a consequence of the imbalance between cell proliferation and apoptosis.

Keywords: Myoma of the uterus, myomatous node, proliferation, apoptosis.

Myoma of the uterus (MM) is the most common reproductive tract tumor in women of childbearing age and occupies one of the leading places in the pathology of the reproductive system [1, 2]. In the dynamics of recurrent MM after ME, morphological and morphometric features of simple and proliferative MM were studied during and outside of pregnancy, complementing the understanding of the pathogenesis of the disease and tumor recurrence after ME. The participation of apoptosis processes in the development of simple and proliferating MM is characterized [3, 4, 5].

The main causative factors and prognostic criteria for relapse of MM after ME have been established (clinico-morphological studies). In the prognosis of relapse, the leading factors were proliferating histotype of MM, hyperplastic processes in the endometrium, endometriosis disease. The proliferating tumor histotype is present in the recurrence of MM after ME with more pronounced mitotic activity compared to the initial parameters. It has been established, in case of relapse of MM after ME, the histological picture of the removed uterus was characterized by multiple true growth zones, rapid and synchronous growth of MU.

Purpose. The study of morphological, morphometric changes in myomatous nodes (MN) in women with uterine myoma (MM).

Materials and methods of research

Morphological, morphometric and immuno-histochemical studies were performed in the department of

pathological anatomy of RSCEMP (head of department, MD, professor BA Magrupov). This work is based on a prospective sample survey, conservative and operative treatment of 285 women with MM of reproductive age who entered the emergency gynecology department. In the morphological study, macro-preparations, MN, removed during the operation, were studied. For this purpose, in each case, MN was taken from the central and peripheral zones, and in the presence of macroscopically visible focal changes – also several pieces of tissue from such foci.

Results of the study and their discussion

Morphological changes in the MN itself had a progressive character and depended on the size and location of MN and the gestational age. The first signs of a disturbance in the blood supply of MN and evidence of compensatory processes developing in the tissue in response to hypoxia were a new formation of capillary vessels, the number of which in the field of view reached 50–60. There were no proliferative changes around the vessels. In the area of ischemia, areas with poorly expressed intermnsular edema with preservation of myocyte nuclei were found. Dystrophic changes increased, manifested by more and more increasing edema of the tissue with the expansion of intermnsular spaces. The vessels of the microcirculatory bed in the zone of pathology were unevenly expanded, full-blooded, single leukocytes appeared in the lumen of individual capillaries. Ischemic changes were followed by the development of necrosis of MN. In the cells of MN, still retaining their structure,

signs of dystrophic polymorphism, the amount of chromatin, indicating the apparent non-viability of the dystrophic cells were determined. Later, with the progression of the circulatory disturbance in MN, pronounced intermnsular edema with a sharp expansion of tissue gaps was observed. Foci of necrosis are formed. Massive leukocyte infiltration completely occupied the whole zone of necrosis, in the same zone there were extensive foci of hemorrhages. Capillary vessels and small arterioles were in the state of paretic expansion, in their lumen were determined fibrin clots, and around perivascular hemorrhages. Edema became massive, forming extensive cavities, delaminating intermnsular gaps, and the phenomenon of myxomatosis appeared.

Regardless of the contingent of patients, proliferative MM during ME was met in 11.3% of women. This indicator is almost the same for non-pregnant and pregnant women, traditionally operated, and significantly higher than in women after LME (20 (12.1%) and 1 (3.3%, $P < 0.05$), respectively. women with SS MN who underwent LME, and such localization of MN is not typical for proliferating MM.

Of the 23 patients with a relapse of MM, repeated ME was performed in 16. Macroscopically, the MN of the relapsed MM had borders with the adjacent myometrium, but their consistency was milder than that of the simple MM. On a cut they had the appearance of a homogeneous tissue, often with multiple hemorrhages, in the form of multiple MNs. In a number of cases, there was a picture of MN necrosis and secondary dystrophic changes in the form of hemorrhage into the tissue of MN, edema, the appearance of leukocytes in the tissue lesion zone. "Endometrioid explants in the myometrium formed" growth zone, and in the endometrium were clearly expressed signs of glandular hyperplasia. In all 16 women, the recurring MM was proliferating. Foci of proliferation of tumor cells were most often localized in the perivascular spaces around the vessels.

In some cases, the entire MM was MN from proliferating myocytes with sinusoidal vessels. The size of myocyte nuclei was fairly homogeneous. Tumor cells maintained monomorphy, mitoses were single, or their number was 5–10 in 10 fields of vision. An increased amount of mitosis was observed predominantly around sinusoidal vessels in growth zones. Myometrium outside MN is hypertrophic. In the stroma, there was an increased

number of capillaries per unit area and their fullness. In addition to the main MN, small MNs were found in the stroma. When the proliferative variant of MM recurred, the histological pattern remained the same. In the tissue, there was an increased formation of new vessels, around them a number of zones of growth of tumor myocytes were determined, and signs of proliferative activity persisted. In all 16 cases of repeated MEA due to the relapse of MM, the proliferating type of MM was detected. Taking into account that the same woman can have different histotypes of MM (multinodular growth), and SS MN are more often simple MM, it can be assumed that a relatively larger relapse rate of MM is associated with more frequent loss of MIs not noticed during LME. The number of myocytes in a simple MM exceeded the norm by 1.5 times, in proliferative – by 4.1 times. The ratio of the area of myocytes and intermnsular space in the uterus without any pathology was 55.9% to 44%, respectively, in a simple MM – 25.3% to 74.6%. Reduction of the area occupied by myocytes with a simultaneous increase in the area of intermnsular space is probably associated with pronounced dystrophic changes in MN and tissue edema, disorders of hemo- and lymphodynamics, destructive changes and necrosis of myocytes. In the proliferating MM, the ratio of the area of myocytes and intermnsular space was 70.7% to 29.1%, which is associated with the pronounced proliferation activity of smooth muscle cells and an increase in their number per unit area. The increase in the volume of MN in the proliferating version of MM is due to cell hyperplasia, and the high proliferative activity of myometrium cells indicates a high potential of tumor growth.

The process of formation of growth zones of MN is inextricably linked with the processes of angiogenesis. The growth and development of MM was accompanied by the formation of new microvessels from existing ones. At the same time, the vessels of the MM differed from normal ones, since they had a sinusoidal structure, which can not be attributed either to the arterial or venous system, and had pronounced morphological features, due to the lack of muscular and adventitious membranes in their structure. The vascular network of simple MMs was expressed in varying degrees. In the morphometric study of a simple MM, the number of vessels of sinusoidal type averaged 85.38 ± 2.6 per unit area under study. The increase in the size of MN with a simple MM was due to a violation of

microcirculation and the development of dystrophic and necrobiotic processes. In such MN, the number of sinusoids increased on average to 100.1 ± 3.9 , which probably served as a manifestation of compensatory processes developing in tissues in response to hypoxia. Proliferating MM were characterized by active angiogenesis processes representing sites with a number of vessels of sinusoidal type and the formation of "growth zones" both in the MN itself and in the surrounding myometrium. The presence of many small, chaotically scattered vessels along the periphery and in the center of the MN was noted, their number on the average reached 227.1 ± 10.0 . Foci of tumor cell proliferation most often localized in the perivascular spaces around the vessels, as well as in the peripheral parts of the MN. In a morphometric study of recurrence of proliferating MM, the number of sinusoidal vessels on average was 190.6 ± 7.4 per unit area. The increase in the number of vessels in the proliferative variant compared with the simple version of MM was 2.7, in comparison with the relapse of 2.2. In the proliferating MM, unlike simple MM, multiple "growth zones" around the vessels were formed and the processes of neoangiogenesis in these MNs were actively proceeding. The high density of microvessels due to the increase in their number in MN was the most significant component in the initiation of tumor growth and it was the presence of sinusoidal vessels that indicated active angiogenesis and the formation of active growth zones in myometrium.

The level of expression of the proapoptotic factor CD-95 (FAS / Apo receptor) was highest in the simple MM ($54 \pm 3.9\%$), the mean in the proliferating factor ($32.5 \pm 1.7\%$), and its lowest value was determined in MN with the relapse of proliferating MM ($9.7 \pm 1.1\%$), which indicated a low readiness for apoptosis of tumor cells, contributing to an increase in its size.

Thus, the development of proliferative processes is due not only to increased proliferation of cells, but also to the weakening of the induction of apoptosis. With low proliferative activity (simple MM), the level of apoptotic activity is high enough. With a high activity of proliferative processes, the level of apoptosis is sharply reduced, i.e. tumor growth can be considered as a consequence of the imbalance between cell proliferation and apoptosis. The source of the proliferation foci in the perivascular zone is vascular wall cells, which is confirmed by studies of expression of the CD-34 marker of the endothelium. In MN, CD-34 was

detected not only in the endothelium of microvessels, but also in individual cells of the vascular wall and perivascular tissue, in the endothelium of the myometrium vessels. A large number of vessels in proliferating MM indicated an increase in the process of neoangiogenesis.

Examination of Ki67 marker expression allowed to evaluate proliferative activity of stromal cells, as the main growth mechanism in MN is the increase of cell proliferation activity. The reaction product of Ki67 was found in the nuclei of the fibroblastic elements of the stroma in the proliferative version of MM and in cases of relapse.

Thus, the results of the studies showed that there is a close relationship between the processes of neoangiogenesis, apoptosis, proliferation, and growth activity in simple and proliferating MM. In simple MM, tumor growth during pregnancy is primarily due to myocyte hypertrophy and secondary changes, myocyte proliferation is low, with low angiogenesis, expression of apoptosis markers is high, growth zones are few. At the base of MN growth during pregnancy (proliferating MM) there is a pronounced proliferation of myocytes, to a lesser extent stromobrazovanie, active angiogenesis, apoptosis sharply reduced.

The mechanism of growth of simple MM in pregnant women is due to stromal-parenchymal relationships and in 39 out of 45 it was characterized by slow proliferative growth and, as a rule, single MN, located predominantly IMI and intermnscularly in the bottom and the uterus. The growth of the tumor during pregnancy was primarily due to myocyte hypertrophy and secondary changes with microcirculation disorders and the development of necrobiotic processes. There were no growth zones in the surrounding myometrium and remote areas of the uterus, proliferative and mitotic activity was low. Secondary changes in MN tumors developed quite often and were manifested by red and hyaline degeneration, edema, necrosis. At there was an accelerated death of myocytes in the central zone of MN. The change in the volume of MN in these terms was associated with tissue swelling, disorders of hemo- and lymphodynamics, destructive changes and necrosis. Morphological changes in NPMNs were clearly related to time boundaries. First, microcirculation disorders and the growth of tissue hypoxia caused compensatory changes in smooth mnscl cells, then decompensation ensued – edema developed, and cell destruction began. Dystrophic changes in the tumor should be considered

not as complications in the development of the latter, but as links in a single process. Pregnancy was the cause of destabilization of blood circulation in MN.

Proliferating MM outside and during pregnancy during relapse is caused by rapid growth, large size, large amount of MN, mainly intermnsular arrangement, more often taking a centripetal growth direction, causing deformation of the uterine cavity. The growth of MN during pregnancy was due to hypertrophy of myocytes and their hyperplasia, active angiogenesis and to a lesser extent stromobrazovanie. In women with repeated ME, conducted in connection with relapse of MM in terms of 1–4 years, proliferating MM was observed in all cases, without exception, characterized by rapid growth, multiple MNs having CM and IMSM location.

Conclusion. The tumor growth was caused, first, by hyperplasia of myocytes with high proliferative activity of myometrium cells, indicating a high potential of tumor growth. Areas of growth are multiple. Proliferating MM was combined with endometriosis (adenomyosis), which potentiated their growth. Secondary changes in MN tumors among non-pregnant women were no different from similar changes in the group of pregnant women. The active form of endometrial hyperplasia was associated with proliferating MM (in patients outside of pregnancy). The expression level of the proapoptotic factor CD-95 (FAS / Apo receptor) was minimal in MN with a pattern of recurrence of proliferative MM in pregnant and non-pregnant women. The processes of proliferation prevailed over the processes of apoptosis.

References:

1. Jancwrek M., Pietura C., Bednarek W. Uterine fibroid embolization // Abstracts of Annual Meeting of the CIRSE – 2003. Antalya / Belek, Turkey.– P. 23–24.
2. Olovsson M., Burlev V. A., Volkov N. I., and co–authors. Cellular proliferation, apoptosis and receptors for steroid hormones in patients with uterine myoma // Obstetrics and Gynecology.– 2005.– No. 4.– P. 23–28.
3. Sinclair D., Gaither K. Fertility Outcomes following myomectomy in an urban hospital setting // J. Nation. Med. Assoc.–2005.– Vol. 97.– P. 1346–1348.
4. Spies J., Warren E., Mathias S. Uterine fibroid embolization: measurement of health–related quality of life before and after therapy // J. Vasc. Interv. Radiol.– 1999.– Vol. 10.– P. 1293–1303.
5. Volkers N., Wouter J., Birnie E., Ankum W., Reekers J. Uterine artery embolization versus hysterectomy in the treatment of symptomatic uterine fibroids: 2 years' outcome from the randomized EMMY trial // Am. J. Obstet. Gynecol.– 2007.– Vol. 196.– P. 5191–5201.

*Yusupalikhodjaeva Saodat Hamidullaevna,
PhD., Tashkent State Dental Institute, Uzbekistan
the Faculty of Therapeutic stomatology
E-mail: syx76.76@mail.ru*

*Bekjanova Olga Esenovna,
PhD., ScD., Tashkent State Dental Institute, Uzbekistan
the Faculty of Therapeutic stomatology
E-mail: bekjanovaolga@mail.ru*

*Patkhiddinov Jaloliddin Sharofiddin o'gli,
student, Tashkent State Dental Institute,
Uzbekistan the Faculty of stomatology*

BACKGROUND DISEASES AT PATIENTS WITH CANDIDIASIS OF ORAL CAVITY MUCOSA

Abstract: Oral cavity mucosa candidiasis develops at pathology of all organs and systems of organism, and crucial role in a pathogenesis of a candidosis infection belongs not only to causative agent, but to condition of a macroorganism.

Keywords: candidiasis, mucous membrane of an oral cavity, candidiasis stomatitis, social and demographic characteristics.

Candidiasis of mucosa of oral cavity and lips (labial) belongs to one of the most widespread diseases in dentistry. In retrospective analysis of frequency of prevalence of candidiasis there is revealed a sharp augmentation of its share (more than 30%) among other nosological forms of diseases of a mucosa of oral cavity [1, 36–38; 2, 34–36; 3, 110–112; 7, 73–74; 10, 429–430; 12, 21–26; 13, 75–77]. This results from the fact that candidiasis develops against the background of certain changes in human body, various pathological states and also due to adverse effects (use of cytostatic agents, antibiotics, hormonal drugs, augmentations of background radiation, etc.) [3, 110–112; 5, 114–116; 6, 5–6; 8, 13–15; 11, 21–25; 14, 316–318]. Candidiasis of oral cavity mucosa (COCM) are a frequent complication at immunocompromised patients, it is shown during the weakening of protective forces of organism, disorder of endocrine functions, digestive and hemopoietic systems, blood circulatory systems, metabolism, at oncologic diseases, HIV infection, intestinal dysbacteriosis, etc. [4, 10–14; 6, 8–14; 7, 74–76; 8, 8–12; 9, 1011–1014; 15, 329–331].

However, despite a large number of publications devoted to question of influence of pathogenic microflora, including sort of *Candida* fungus on a homeostasis of hard

and soft tissues of oral cavity, we didn't find the works dedicated to studying the problem of candidiasis of oral cavity in combination with background somatic pathology.

Objective of research: to define background diseases and risk factors of development of a candidiasis of OCM.

Materials and methods. This research was prospective (on time of data collection and formation of selection), dynamic (in temporary parameters), observation). The research was carried out within 3 years (from 18 to 65). A research object – patients with candidiasis of oral cavity. 323 patients were examined. Main group was comprised of patients with candidiasis OCM – 173 persons (53, 56%) and 150 patients (46,44%) without symptoms of pathology of OCM made group of control. Clinical trial was referred on identification of a basic disease and possible risk factors, included: collecting of complaints, anamnesis, objective survey, detection of associated diseases, all-clinical laboratory trials.

A diagnosis of OCM candidiasis was made in the presence at patient of characteristic changes of oral cavity, identification of mycelium, pseudo-mycelium, heaping *Candida* spp cells. In colored smears prints of mucosa of oral cavity and (or) signs of invasive body height of fungus or allocation of causative agent at inoculation of biopsy material.

Statistical analysis of obtained data was carried out by means of parametrical and nonparametric methods, using program Statistica for Windows 6.0 (StatSoft, Tulsa, Okla). For quantitative assessment of results of conducted researches there has been used the relation of chances (OR). Indicator of OR was counted for interrelation assessment between factor of influence (risk factor) and risk of development of disease. Interpreting of indicator was carried out as follows: when OR was more than unit (with account of confidential intervals for this indicator), development of a recurrence could be bound to action of this risk factor. If OR was less than unit or less unit, then factor of influence didn't exert impact on result. Assessment of importance of differences was carried out by criterion for assessment of zero hypothesis with calculation of level p and by method of the confidential intervals (CI) [Rebrova, 2002; Plavinsky, 2010].

Results and discussions. Patients were presented by age groups from 18 to 65 years and older. Compared groups of patients were randomized on signs of age and gender. All patients had duration of a disease from 1 to 3 years and frequency of a recurrence not less once a year.

Considering that the patients having additional background diseases and risk factors such as can have a candidiasis at the same time: existence of malignant

neoplasms and endocrinopathies, use of antibacterial drugs of a broad spectrum of activity, cytostatic agent, inhalation and peroral glucocorticosteroids, so we have carried out inspections on existence of background pathology at patients with clinically diagnosed with OCM candidiasis. As a result of comprehensive examination we revealed the groups of background diseases of attendees at patients with OCM candidiasis.

Clinical inspections established direct dependence of prevalence of OCM candidiasis and age of patients. At the same time main specific gravity in a total amount of patients falls on age period from 34 to 64 years and is more older (more than 67,63%) of patients. It is possible to assume that so high case rate of adult population is explained by higher frequency of background somatic pathology, frequent reception of antibiotics and hormonal (steroid drugs).

It is necessary to notice that vast majority of surveyed 95 (54.91 ± 3.78%) had disease duration of more than 3 years; patients suffered from candidiasis from 1 year to 3 years 51 (29.48 ± 3.46%) and only 27 (15.61 ± 2.76%) had rather short term of a disease – to 1 year. Apparently their data presented in table 1, practically on all groups on groups of patients on MKB – 10 higher frequency of background somatic pathology has been found in patients with OCM candidiasis.

Table 1. – The frequency of somatic pathology in patients with candidiasis oral mucosa

№	Group of diseases according to the ICD – 10	Code for ICD – 10	Main group n = 173	Control group n = 150
			number of diseases / abs number of diseases%	
1	2	3	4	5
1.	Gingivitis and periodontal diseases (K05)	K05	$\frac{150}{86.71} \pm 2.58$	$\frac{75}{50.0} \pm 4.08$
2.	Circulatory system diseases (100–199)	100–199	$\frac{62}{35.84} \pm 3.65$	$\frac{18}{12.0} \pm 2.12$
3.	Nervous system diseases	G00-G99	$\frac{26}{15.03} \pm 2.71$	$\frac{17}{7.33} \pm 2.12$
4.	Blood and hematopoietic organs diseases	D50-D89	$\frac{92}{53.18} \pm 3.80$	$\frac{49}{32.67} \pm 3.84$
5.	Urinary system diseases	N30-N39	$\frac{61}{35.26} \pm 3.63$	$\frac{25}{16.67} \pm 3.04$
6.	Ear and mastoid process diseases	H60-H95	$\frac{18}{10.40} \pm 2.32$	$\frac{6}{4.0} \pm 1.60$
7.	Eye diseases	H00-H59	$\frac{52}{30.05} \pm 3.48$	$\frac{37}{24.66} \pm 3.53$

1	2	3	4	5
8.	Endocrine system with disorders of delivery and metabolism	E00-E90	$\frac{64}{36.99} \pm 3.67$	$\frac{15}{10.0} \pm 2.45$
9.	Digestive organs diseases	K00-K93	$\frac{76}{43.93} \pm 3.77$	$\frac{38}{25.33} \pm 3.53$
10.	Respiratory organs diseases	J00-J99	$\frac{32}{18.50} \pm 2.95$	$\frac{12}{8.0} \pm 2.21$

Note: in the numerator – an absolute number, in the denominator-%

Thus range of background diseases at development of OCM candidiasis is rather wide and includes practically all studied classes of diseases, reliable correlation dependence isn't established only on group of diseases of eyes.

Measure of association allows estimation of communication force between an outcome and factors

which these cause an outcome. S main measure of association is relation of chances. Calculation of relation of chances allowed to allocate the most significant groups of background pathology of development of OCM candidiasis in the studied group of patients (Table 2).

Table 2. – Relative of risk and chances of weighting of the somatic status in the implementation of OCM candidiasis

№	Risk Factor	OR relation of chances	S error	Confidence Interval
1.	Gingivitis and periodontal diseases	6.522	0.277	3.788–11.227
2.	Circulatory system diseases	4.096	0.297	2.288–7.333
3.	Nervous system diseases	2.139	0.379	1.017–4.96
4.	Blood and hematopoietic organs diseases	2.341	0.231	1.488–3.684
5.	Urinary system diseases	2.723	0.271	1.602–4.630
6.	Ear and mastoid process diseases	2.787	0.485	1.076–7.217
7.	Eye diseases	1.312	0.252	0.801–2.15
8.	Endocrine system with disorders of delivery and metabolism	5.284	0.314	2.853–9.787
9.	Digestive organs diseases	2.309	0.242	1.436–3.713
10.	Respiratory organs diseases	2.610	0.359	1.291–5.276

Following the (table 2) – all analyzed risk factors have an indicator over 1, therefore they are risk factors, that is confirmed by positive indicators 95% DI. **Carried-out analysis showed that** the chances of development of OCM candidiasis is highest for such risk factors as gingivitis and illnesses of the parodont – 6.522 (95% 3.788–11.227); diseases of endocrine system. disorder of nutrition and metabolism-5.284 (95% 2.853–9.787); diseases of blood circulatory system – 4.096(95% 2.288–7.333); diseases of ear and mastoid – 2.787(95% 1.076–7.217); diseases of urinary system – 2.723(95% 1.602–4.630); diseases of respiratory organs – 2.610(95% 1.291–5.276); diseases of a blood and hemopoietic organs

– 2.341(95% 1.488–3.684); diseases of a nervous system – 2.139(95% 1.017–4.496); diseases of digestive organs – 2.309(95% 1.436–3.713) and diseases of eyes – 1.312(95% 0.801–2.150).

By results of this researches OCM candidiasis develops at pathology of all organs and systems of organism, and crucial role in a pathogenesis of a candidosis infection belongs not only to causative agent, but to condition of a macroorganism. A releaser of development of lesion OCM candidosis is complex relationship between macro – and microorganism. Disturbance of reactions of immunoregulation and change of resistance factors of a macroorganism – on one hand, in-

crease of fastness of microorganisms to germicides – on other hand define risk of development and gravity of OCM lesion. At the same time metabolic disturbances and other diseases leading to development of immunodeficiency can be factors contributing to development of candidiasis. It is possible to assume that development of secondary candidiasis complicates the course of chronic disease, and use of antibacterial therapy, glucocorticosteroids and immunosuppressive treatment aggravates this vicious circle.

Conclusion. Thus, in analysis of background somatic pathology at patients with OCM candidiasis the most significant risk factors of its development are allocated such as diseases of parodont, diseases of a metabolism, endocrine system. It is necessary to notice that OCM candidiasis can be complication of any group of diseases. At the same time it is important to focus attention on controlled or partially controlled risk factors of OCM candidiasis noted during the given research. Further it will help with creation of individual plan of measures on prophylaxis of a disease.

References:

1. Beybulatov G. D., Ostrovskaya L. Yu., Lepilin A. B. Factors influencing the development of the candidate-associated parodontitis // Russian Dental Journal.– 2014.– No. 4.– P. 36–38.
2. Drobotko L. N., Kiselnikova L. P., Seydokin A. G., Dronov I. A. Fungal diseases of the oral cavity // MEDICAL COUNCIL – No. 9.– 2017.– P. 33–41.
3. Kochneva E. V. Determination of pathogenicity factors of *Candida fungi albicans* and their role in the development of the infectious process / Topical issues of modern medicine: a collection of scientific papers on the results of the inter-university annual correspondence scientific and practical conference with international participation, Ekaterinburg, March – 2014 / ICTRON.– Ekaterinburg,– 2014.– P. 110–113.
4. Melekhina Yuliya Emmanuilovna. Clinico-immunological features of recurrent esophageal candidiasis: A vtoref. dis.cms,– St.-Petersburg,– 2015.– 22 p.
5. Nenasheva N. M. Safety of inhalation glucocorticosteroids in the therapy of bronchial asthma // Pullmontology.– 2014.– No. 3.– P. 113–120.
6. Raidenko O. V. Superficial skin fungal infections in HIV-infected patients: etiology, clinical features, diagnosis and treatment: Abstract IS.d. cms,– St.-Petersburg,– 2014.– P. 22.
7. Reshetnikova I. D., Tyurin Yu. A., Glushko N. I., Lisovskaya S. A., Mustafin I. G., Fassakhov R. S. 1 Virulent properties of *Candida fungi* in patients with persistent bronchial asthma, long-term inhalation steroids // Pulmonology.– 2014.– No. 3.– P. 73–77.
8. Tilavberdyev Sh. A. Clinico-immunological characteristic oral candidiasis in immunocompromised mucosa GOVERNMENTAL: Avtoref. dis. cms. Tashkent.
9. Brusca M. I. The impact of oral contraceptives on women's periodontal health and the subgingival occurrence of aggressive periodontopathogens and *Candida species* / M. I. Brusca, A. Rosa, O. Albaina et al. // J Periodontol.– 2010.– Vol. 81.– No. 7.– P. 1010–1018.
10. Canabarro A. Association of subgingival colonization of *Candida albicans* and other yeasts with severity of chronic periodontitis / A. Canabarro, C. Valle, M. R. Farias et al. // Periodontal Res.– 2013.– Vol. 48.– No. 4.– P. 428–432.
11. Cornely O. A. ESCMID guideline for the diagnosis and management of *Candida* diseases – 2012: non– neutropenic adult patients / O. A. Cornely, M. Bassetti, T. Calandra et al. // Clin Microbiol Infect.– 2012.– Vol. 18.– Supp I7.– P. 19–37.
12. Cuesta A. I. Prevalence of *Staphylococcus spp* and *Candida spp* in the oracavity and periodontal pockets of periodontal disease patients (A. I. Cuesta, V. Jewtuchowicz, M. I. Brusca et al. // Acta Odontol Latinoam.– 2010.– Vol. 23.– No. 1.– P. 20–26.
13. Costa KR D. A., Ferreira J. C., Komesu M. C., Candido R. C. *Candida albicans* and *Candida tropicalis* in oral candidosis quantitative analysis, exoenzyme activity, and antifungal drug sensitivity // Mycopathologia.– 2009.– Vol. 167.– No. 2.– P. 73–79.

14. Duggan S., Leonhardt I., Hünninger K., Kurzai O. Host response to *Candida albicans* bloodstream infection and sepsis. *Virulence.* – 2015; 6 (4): 316–26. doi: 10.4161 / 21505594.2014.988096. Epub – 2015. Mar 18.
15. Jonathan P. Richardson and David L. Moyes Adaptive immune responses to *Candida albicans* infection *Virulence.* – 2015. May–Jun; 6 (4): 327–337. Published online – 2015. Jan 21. doi: 10.1080/21505594.2015.1004977
PMCID: PMC4601188

Section 8. Pedagogy

*Dolinskaya Ludmila Vasilievna,
Odessa State Environmental University,
Chief of the Laboratory of the College of Computer Technology
E-mail: lslvvas@ukr.net*

PEDAGOGICAL CONDITIONS OF TRAINING OF THE TECHNICAL PROFILE SPECIALISTS TO CARRY OUT TRAINING ACTIVITIES IN HIGHER EDUCATION SHOOOL

Abstract: The analysis of possible use of the integrating approach, which is applied when training future teachers, graduates of technical specialties to carrying out training activities in a higher educational institution, was carried out. Skills which correspond to readiness of a teacher, who has higher education, to manage the educational activity of subjects of training are defined.

Keywords: pedagogical training, management, educational process.

Actuality. In the course of carrying out training activities the teacher should not only have a wide range of special knowledge, but also knowledge, and, especially, understanding of the basic principles, provisions and laws of pedagogics (didactics, in particular), psychology and techniques of teaching a training material is required. A key indicator of teacher's professionalism is the ability to create a particular training system and to provide optimal level of regulation correctly and in time. This ability also means to manage with adjusting the course of training process [1]. It is reached by implementation of effective (operational) diagnostics of knowledge and students' skills [2]. Such approach allows to plan accurately and to predict training process correctly [3].

Until recently, pedagogics and psychology consciously relied only on specific patterns of training process which were already reported in works [2, 4, 5]. The general patterns of training of technical profile specialists (graduates of engineering specialties) in pedagogical (teaching) work were applied (and are still applied!) almost, instinctively, one may say, blindly, they are not always reasoned and proved. Unfortunately, it was supposed that future teacher, a teacher – the graduate of a higher educational institution (of a technical profile, in

particular), is ready, by default, to carry out and manage the educational process, and is capable to provide necessary quality of students' training. Therefore the specifics of professional training goals of future teacher having technical education include the detection of all range of his/her practical activities that defines tasks and the goals of studying special and technical disciplines.

There is an indisputable fact that the ultimate goal of training of specialist's teachers (with basic technical education) in higher educational institutions on postgraduate education departments, in the magistracy, or during a postgraduate study is defined by requirements of society and the social order of the state. Therefore, content, forms and types of educational activity of the training subjects must be flexible, i.e., adaptive for of time and social requirements. Having gained knowledge, having created abilities, teachers-specialists, trained again, further have to master and improve the professional and pedagogical skills on the specific pedagogical platform in the future – in technical university, college, or technical school. That is why researches which are directed to detailed studying and development of future specialist "portrait" of different technical profiles and oriented for professional and pedagogical work are of particular importance. Creation and enforcement of qualification

characteristics of the teachers having vocational technical education (engineers technicians and technologists, electrical and mechanical engineers, software engineers, engineers in the field of SAPR, etc.) [4] have become practical results of such researches.

Problem definition. The purpose of work is confined to defining content and a training technique of specialists technicians for carrying out training activities in higher education institutions of a technical profile. To achieve this purpose we set the following tasks: to analyse the training of specialists of a technical profile (graduates of engineering specialties) to participation in educational and pedagogical work; to define main skills needed in the course of professional training of students.

Material statement. The qualification characteristic of university graduates of a technical profile assumes that the student has to acquire skills in the following types of activities: general education; basic technical; special technical; engineering; social and humanitarian; production and management; cultural and educational; social and economic [3, 5].

In spite of the fact that the management activity is allocated in the qualification characteristic, content and methods of preparation for this type of activity are not disclosed thoroughly and not studied in detail. It is confirmed by the fact that management of educational process and teaching work are actually separated. Graduates of a technical profile get “a subject education”, i.e., formally they have a right to teach subjects they have studied, but, unfortunately, they have no practical skills in teaching and management of training process.

Graduates of pedagogical higher education institutions do their teaching work-study programmes which are obligatory. Professional and pedagogical training of future teachers is performed on the basis of curricula and training programs of courses which correspond to a certain specialty.

Having analysed the curricula of technical specialists training according to preparation cycles (humanitarian and socio-economic, mathematical, natural-science, professional and practical), we defined the disciplines studying which, it is reasonable to develop knowledge and abilities which are necessary for forming of pedagogical skills of a future teacher.

In the course of studying a training material on technical disciplines, the implementation of the elements of

“Pedagogics”, “Psychology” and “Teaching Techniques” (even in a format of an elective course or a scientific and pedagogical extracurricular activity) opens a possibility of forming absolutely new pedagogical knowledge. This process can be implemented by the following ways: 1) theoretically reasonable and systematic control of knowledge; 2) qualitative and quantitative analysis of achievements level of subjects of training in training process; 3) forecasting of difficulties and mistakes which students could face; 4) stimulation and organization of different forms of educational activity; 5) increasing of a motivational component of training process, taking into account new tendencies in development of science, technologies and production.

We assume that formation of pedagogical, scientific and methodical knowledge and abilities by technical profile specialists during studying a training material on special disciplines can be implemented by merging of special knowledge and a technique of their statement. Besides, the analysis and selection of a training material must be in accordance with the training purposes, taking into account the level of educational achievements of subjects of training.

Introduction of a subject “Teaching technique” is necessary for training the future technical profile specialists for pedagogical work, and also for managing the educational process. Carrying out students’ teaching work-study programmes is especially important, for example, if it is based on the same higher education institution, and with participation of junior students. At the same time students who are going to be engaged in pedagogical work in the future can be involved in teaching work-study programmes. Knowledge and skills in development curricula of teaching and educational work for a year or a semester are also formed. Skills of a correct formulation of a lesson subject, the purpose and problems of training are developed. Students gain experience of the correct qualitative and quantitative estimation of educational achievements level of subjects of training.

In the process of studying the majority of themes on disciplines “Pedagogics”, “Bases of scientific research”, and also organizing students’ practical research work, new opportunities are developed, i.e. knowledge and skills to carry out different forms of diagnostics: conversation, observation, questioning, testing, sociometry, statistical processing of research results etc. Students offer

models of their own teaching technique, using modern innovative technologies and scientific approaches.

Formation of knowledge and skills on the basis of "Psychology" is another important component. This discipline is directed to receiving and fixing the information necessary for management of group of training subjects.

It is possible to assume that when studying the disciplines mentioned above, students successfully acquire knowledge and skills of pedagogical and managerial character. Nevertheless, in practice, even successful students face huge problems.

Defining such concept as "training of future teachers of technical disciplines for carrying out training process of subjects of training", we draw a conclusion that it includes such basic characteristics as "training", "teaching", "management of educational activity". Under a definition "training", we will understand the purposeful system-structured study, a transfer of necessary knowledge and skills for future professional work of the graduate of the technical direction of training. Readiness of the teacher of technical disciplines for training process control forms through the process of "training". Correct organization and correct management in education comes to a front boundary in improvement of knowledge quality of youth today. Readiness of a teacher for carrying out and managing the educational activities is fully formed and rather accurately expressed level of a motivational direction and professionally significant qualities and abilities which allow to perform tasks of coherent pedagogical process.

From our point of view, readiness of future teachers of technical disciplines for monitoring procedure of educational activity of subjects of training of higher education institutions of a technical profile is defined by the following: a) profound and strong knowledge in the field of pedagogics and psychology (together with understanding of the sense of pedagogical work); b) successful mastering difficult management and pedagogical skills which are necessary for practical work; c) awareness of interrelation between elements of knowledge and skills acquired by subjects of training; d) use of theoretical knowledge and skills in practice.

Pedagogical theory and teaching work-study programmes are the driving force of forming process of a system of knowledge and skills of teachers – those who graduated from technical higher education institutions. Pedagogical theory and practice disclose wide perspec-

tives for activation of teachers' creative activities while carrying out studies. They also motivate an interest in acquiring new, progressive system of knowledge and skills. Therefore process of teachers' training for management of educational activity of subjects of training has must be considered according to system approach [1, 3, 5]. From our point of view, it is necessary for teachers of this type to form the skills which allow to integrate psychological and pedagogical, methodical, fundamental and applied, scientific, special and technical knowledge. Ability to create a system of control and diagnostic, informational and analytical, motivational and targeted, planned and predictive, organizational and research, regulatory and correctional knowledge has to be brought to a high level.

On the basis of the analysis carried out we can identify two components of readiness of technical specialties graduates of higher education institutions for pedagogical work and to control the quality of training of the training subjects. The first component is theoretical. The development of system of knowledge of didactics, psychology and teaching technique (special disciplines, in particular) is expected here. Skills in the field of management are also of great importance [6]. The second component is active and practical. It encompasses forming of pedagogical and managerial skills, capability of future teacher to carry out a specific management activity on the basis of earlier acquired knowledge and a desire for self-training and self-development.

So, proceeding from the categories and terms analyzed above which create the concept "training of future teachers of technical disciplines for carrying out training process of subjects of training", the last can be provided in the context of the research conducted by us, namely, "Training for carrying out study of subjects of training" is a difficult multilateral process of transferring theoretical knowledge and practical skills with implementation of the systematic, predicted and technology secured, directed to creation of optimal conditions for achievement of high standards of knowledge and skills to carrying out studying of subjects of training to students.

Management of education quality is implemented by a teacher through two function blocks. The first function block provides management of educational cognitive activity to carrying out studying of subjects of training. It includes the following functions: pedagogical, scientific and methodical, control and diagnostic, information and

analytical, motivational and targeted, planned and predictive, organizational and executive, regulatory and correctional. The second function block is directed to increase the professional and pedagogical level of subjects of training. It provides pedagogical introspection (reflection); increasing of special training level; increasing of psychological, pedagogical and methodical levels of training.

Conclusions. The analysis of training of university graduates of a technical profile for pedagogical work, management and carrying out training of subjects of training, which was carried out by us, allowed to define those skills which are the main in the course of professional training of students of a technical profile.

It is necessary to emphasize that a graduate of a higher educational institution who will be engaged in pedagogical work should conform to the following requirements: 1) to be able to organize and carry out psychological and pedagogical diagnostics using different forms and techniques (conversations, observations, questioning, testing, sociometry, statistical data analysis); 2) to be able to combine psychological and pedagogical diagnostics with a training material when studying special (technical) disciplines, predicting mistakes, training results and difficulties which subjects of training could face; 3) to be able to develop curricula of teaching and educational work for a year or a semester planning the work in the context of management of educational activity of subjects of training; 4) to formulate a subject and the purpose of a lesson correctly and accurately and, on the basis of it, to set tasks, both for himself/herself and for subjects of training; to carry out introspection of a lesson (a lecture, a practical and laboratory lessons, an educational seminar; 5) to increase the level of requirements, stimulating work with students in accordance with tendencies of their development and at the same time changing a lesson course quickly, considering results of psychological and pedagogical diagnostics; 6) to connect current instructing and operating control of knowledge of subjects of training by implementation

of individual approach and at the same time to undertake self-education; 7) to engage the subjects of training, to interest them in new scientifically significant perspectives, using different forms of educational activity; to select thoroughly and analyze a training material according to the training purposes, taking into account the level of readiness of subjects of training; to master and improve continuously a technique of teaching a subject; 8) to consider relationships between subjects of training, to understand features of interpersonal likes and dislikes in the course of their grouping for accomplishment of the common academic task.

Finally we should notice the following thing: in spite of the fact that forming of all-pedagogical knowledge and skills is a long process, pedagogical readiness of the graduates of a technical higher educational institution has to be implemented systemically and completely throughout the whole period of their training [1]. At the same time it is necessary to consider the fact that scientific and methodical, pedagogical training of students of the technical direction of education is a continuous change of pedagogically reasonable, consecutive training stages during which specific objectives of development and education of the teacher's identity are solved. Specifics of a training process in a higher educational institution are that this process is value-based. We should notice that it is quite difficult to monitor all types of those factors which create a system and also types of connections between system elements, the nature of interactions between elements of such systems [5]. These positions distinguish between an educational process and a production process. The last, mostly, acts as the process oriented towards the accomplishment and achievement of a specific production objective and the accomplishment of some material designated purpose [6].

Perspectives of further researches consist in development of model of training of teachers – graduates of the technical direction of training – to organize and carry out pedagogical work.

Referances:

1. Babansky Yu. K. Optimization of teaching and educational process: Methodical bases / Yu. K. Babansky.– M.: Education,– 1982.– 192 p.
2. Technique of application of block diagrams of processes of group and individual forms of education / V. V. Kovalchuk, L. V. Dolinskaya, S. V. Ryabchenko, V. V. Skalozub // Bulletin of the Chernihiv national pedagogical university of T. G. Shevchenk "Series: Pedagogical sciences".– 2017.– Issue 150.– P. 13–18.

3. Psychology of training of adults / Yu. N. Kulyutkin.– Press: Prosveshcheny, 1985.– 128 p.
4. Dolinskaya L. V. Forming and improvement of profesionalno-pedagogical qualities of graduates of the technical direction of education // Bulletin of the Chernihiv national pedagogical university of T. G. Shevchenk “Series: Pedagogical sciences”.– 2017.– Issue 149.– P. 158–163.
5. Dolinskaya L. V. Forming of professional competence / V. V. Kovalchuk, L. V. Dolinskaya, // Quality management of training of specialists: materials H_H of the international academic and research conference.– Odessa: Odessa state academy of construction and architecture.– 2014.– P. 38–39.
6. Dolinskaya L. V. Bases of the theory of management from a position of the system analysis / V. V. Kovalchuk L. V. Dolinskaya // Odessa: publisher Bukayev Vadim Viktorovich,– 2017.– 210 p.

*Rakhmatov Uchkun Ergashevich,
senior teacher, Tashkent state pedagogical
university named after Nizami,
E-mail: shga2065@yandex.ru*

A PERFECTION OF THE PROFESSIONAL COMPETENCE OF TEACHERS BY USING OF CREATIVE WORKS IN BIOLOGY LESSONS UNDER SOLVING TASKS AND EXERCISES

Abstract: The article summarizes the experience work of the department of Methodology of teaching biology of Tashkent State Pedagogical University named after Nizami on improving the professional competence of the biology teacher of secondary schools by solving tasks and exercises. By stimulating the thinking and cognitive activity of pupils and increasing their own efforts in mastering knowledge in solving tasks and exercises in biology at all stages of education, it is possible to achieve the development of cognitive interest in biology.

Keywords: biology lesson, schoolchildren, solution of tasks and exercises in biology, teaching methods, pedagogical technologies.

Modern school requires a lot from the teacher and deep scientific training, high skill, unconditional pedagogical literacy and competence.

Teaching biology involves the use of various means and methods of teaching.

The tasks of my research of pedagogical activity are multifunctional, but the main ones are:

1. To increase the motivation to teaching biology in solving tasks and exercises by using of modern pedagogical technologies, methods of developing training.
2. To develop creative and mathematical thinking, memory, biological speech of pupils in solving tasks and exercises in biology.
3. Create optimal conditions at the lesson for the development of each pupil in solving tasks and exercises in biology.

It is necessary to use modern pedagogical technologies, methods of developing teaching for solving tasks and exercises in biology to implement the planned tasks. I consider the various activities of pupils at lesson, which they will make interesting the lesson. At each lesson it will be demanded to have a workbook and a textbook to solve tasks and exercises. It is necessary to maintain a positive emotional attitude of the lesson, this will contribute the pupils' cognitive interest to the subject. For each lesson in biology, we must select and develop tasks and exercises that they will determine the rational methodology.

We can differentiate tasks and exercises by the degree of helping to the pupil from the teacher's side, according to the degree of independence of pupil in the performance of tasks and exercises. This is especially important for weak pupils. The work should be organized in such a way, that the degree of independence of schoolchildren increases by time, and the dose of help decreases. For such differentiation, there is an accumulated didactic material with samples of assignments, reminders – supportings, reminders – algorithms [4].

No rejecting the traditional methods of constructing of a lesson, we can apply unconventional forms. The lesson of forming a new knowledge is a lesson-research, lesson-journey. Lessons in testing knowledge are credits and quizzes. Applying different forms of organization of educational activities of pupils are individual, group and frontal.

In the lessons of biology, for the development of the cognitive interest of pupils, it is necessary to use all kinds of biological tasks and exercises. It is true that if there is no cognitive task, there is no work of thought, there is a task – there is a search for its solution. A setting of tasks in the teaching process increases the pupil activity. Pupils explore the phenomenon, look for ways to solve them, put forward various assumptions, bring evidence, and this, undoubtedly, contributes the activation of the thinking activity of schoolchildren, the development of

logical thinking, cognitive independence and, in conclusion it helps to create formation and development of cognitive interest to biology [1, 3].

In biology classes, we can use the following types of tasks:

- tasks, they promote the development of logical thinking.
- task, can help to recognition of natural objects.
- task, they serve the forming of skills, advance and prove hypotheses.
- tasks, they promote the development of research skills.
- tasks, they help to connect the theoretical knowledge with practical ones.
- tasks, related to introspection.
- tasks, containing new information for pupils.

Pupils find for themselves a lot of interesting and cognitive facts in the performance of assignments and exercises; this will facilitate the teaching of complex topics, as well as provide new approaches to testing pupils' knowledge.

The choice of a creative task is a creative task for the teacher, since it is required to find a task that would answer the following criteria:

- A creative task does not have a single-valued and monosyllabic answer or solution;
- It is practical and useful for pupils;
- It is related to the life of pupils;
- It brings an interest to pupils;
- It maximizes the teaching goals.

The ideal didactics is its absence. The pupil strives for knowledge in such a way, that nothing can stop him or her. For this, various tasks and exercises are offered, from which the pupil has the right to choose, what does he like:

- makes a drawing on the topic;
- creates a scheme of a supporting summary;
- thinks up a biological task on the topic;
- selects an example on the topic from the additional literature;
- compiles a crossword;
- thinks up a fantastic story, for example “A life of the organism in a new habitat”;
- thinks up with experiments.

The application of creative tasks in the lessons of biology leads to more effective self-realization of the pupil and makes a preservation of his or her individuality. Pu-

pils are not afraid of new bold non-standard solutions, they may reconsider their views and actions, their mistakes, and they may disagree with the teacher's opinion, so they suggest a better solution to the problem [2].

As a result of solution of creative tasks in the classroom pupils can improve the assimilation of educational material, forms intersubject communications. To activate the cognitive activity of pupils in the process of studying biology – the creation of a problem situation on the basis of statements. I suggest, that pupils will comment on the statements:

1) “Who does not love nature, one does not love human”. F. Dostoevsky.

2) “Grandiose things are done by grandiose means. One nature does a great work for present”. A. Herzen.

3) The well-known geographer and traveler A. Humboldt asserted, that “human is preceded by forests, and accompanied by deserts.” Why does the scientist think so?

The activation of cognitive activity in the teaching of biology allows us to achieve certain results:

1) a teaching activates mental activity, so it is very difficult to learn by pupil, but especially with interest;

2) the majority of pupils had a positive motivation for studying the subject, cognitive interest is not only in particular topics of the course, but in general, in biology;

3) the effectiveness of intellectual and creative abilities of pupils increased.

I believe, that in the process of such an organization of training, the pupils seize different roles in educational cooperation, acquire independence, confidence, master various forms and means of cognitive and communicative activity.

In conclusion we want to note:

1. By stimulating the cognitive activity of pupils and increasing their own efforts in mastering of knowledge under solving tasks and exercises on biology and at all stages of education, it is possible to achieve the development of cognitive interest in biology;

2. In teaching of solving tasks and exercises in biology, we must actively work on the development of all pupils, among strong and weak pupils in academic performance;

3. The use of the considered methods in the educational process promotes the development of cognitive interest, deepens the knowledge of pupils in solving tasks and exercises in biology;

4. Pedagogical theory is developed by teacher's methodological skill and this stimulates mastering. Therefore, the system of methodical means and techniques of activating of cognitive activity in solving tasks and exercises in biology for schoolchildren is essential index in practical mastering by each teacher, in the development of appropriate skills and abilities.

References:

1. Kornilova E. A. Modern approaches to constructing of a lesson in the condition of the realization of federal state educational standard C (from the experience of teaching natural-mathematical disciplines): A methodical manual / Edited by Kornilova E. A. [Text] – Belgorod,– 2015.–72 p.
2. Modestov S. Yu. Collection of creative tasks in biology, ecology and basis of life safety: a manual for teachers / S. Yu. Modestov. [Text] – Sankt-Petersburg,– 1998.– 175 p.
3. Serikov V. V. Education and personality. Theory and practice of designing pedagogical systems.– M.: The publishing corporation “Logos”,– 1999.– 272 p.
4. Rakhmatov U. E., Shakhmurova G. A., Azimov I. T., Rakhmanov J. A., Azimov B. I. Solution of biological problems and exercises (basics of cytology and genetics). Teaching – methodological guidance. Solution of biological problems and exercises (basics of cytology and genetics). Teaching – methodological guidance. T. “Literature Sparkles”.– 168 p.

*Khasanova Gulsanam Khusanovna,
senior teacher, of Andijan retraining public education personnel
and in-service training regional center under
Andijan state university, Uzbekistan
E-mail: kuzinka1982@bk.ru*

ESSENTIAL FEATURES OF VOCATIONAL EDUCATION SYSTEMS IN UZBEKISTAN AND JAPAN

Abstract: This work is dedicated to one of the most pressing issues of today – the study of the formation and development of the Uzbek and Japanese vocational education, study and comparison of experience the functioning of educational systems, which focused on education of physically and spiritually developed generation. In recent years, there has been a rising global need to train and educate certain number of workers to possess high quality, relevant vocational skills which leads to an enormous increase in the demand for vocational education and training. The article analyzes and compare the competitiveness of vocational system of Uzbekistan and Japan qualitatively and quantitatively and then gives some suggestions on Uzbekistan's vocational education development.

Keywords: openness, continuous education, international standards, intellectual potential, distinguishing features, further perfection.

One of the driving forces of progress in any field of human activity and knowledge is the synthesis of the accumulated world experience. In the context of the reform of the education system in our country, the study and analysis of the trends in the development of education abroad is becoming vital importance. As is known, democratization processes are currently taking place in education systems in the leading countries of the world. Its essential feature is the openness, continuity of all its stages. The theoretical basis of the principle of continuity in the education system is the concept of continuous education. Nowadays the world community determines the content of the new education, the newest technologies of education are developed and introduced, and the educational process is constantly being improved. This is facilitated by many important factors: the ever-increasing volume of knowledge, skills and abilities necessary for students, the experience of educational institutions in different countries. In addition, world education must correspond to a new level of production, science, culture. So, the renewal of the education system is an actual, inevitable task. Education is one of the decisive values of life. The desire for education is determined not only by the desire to acquire knowledge as a guarantor of the extraction of material

goods, but also by the awareness of the need for a broad culture. Therefore, we can say that a comparative analysis of different education systems and the identification of specific approaches to the content of education make it possible to identify the prerequisites and trends in the formation of a single educational space. Issues of development vocational education depend largely on the study of the world experience. The educational system of each country has its own specifics, expressed in actual goals and objectives, methods and forms of training of students, the material basis of features, the system of selection and training of students, staff and others. The world experience of training is useful to study all regardless of the level of material welfare of the population, social and economic development of the country.

In Uzbekistan, people under the age of 30 comprise approximately 60% of the total population. The essence of educational reform in Uzbekistan is to preserve the present intellectual potential of the educational system and to modify our goals and activities in order to develop individuals who are capable to build and to live in a democratic civil society and a free market economy. Therefore, one of our main goals is to educate and train a healthy generation, both physically and mentally.

Considering the principals and experiences of developed countries of the world, Uzbekistan has recognized its main direction of educational development. They include the following [5]:

- Modification and further perfection of the education and socialization content;
- Development of new school, curricula and textbooks;
- Stress on individual ability and talent;
- Vocational and professional development in accordance with changing economic needs;
- Integrating Uzbekistan with world educational standards.

We realize one of the main results to accomplishing educational reform is changing the thinking and mentality of our people and society. It is of great importance. At the same time we understand that by striving to create a new education system according to the world international standards, we will achieve success not only in our country, but we might by sharing our knowledge and experience with developing countries and add our contribution to the world educational system.

Analysis of international experience is becoming the most important resource of modernization of vocational training. The modern system of education can be estimated from the index level of education in the countries of the world (Education Index), the combined index of the United Nations Development Programme (UNDP), is calculated as the adult literacy index and population index combined percentage of students receiving education. It is considered that developed countries should have a minimum index of 0.8, although they had a rate of 0.9 or higher in the vast majority. Of the 187 countries participating in the ranking, the educational index in Uzbekistan is 0.651 (93th place), for Japan, it was 0.808 (26th place), (the maximum in Australia – 0.927 minimum in Niger – 0.198). According to these data, Japan refers to the high country levels of literacy [9]. Education in the country is traditionally a prerogative of the state, which has not lost its social significance to this day.

Analysis of the dynamics of change quantitative and organizational forms of vocational education of Uzbekistan, by the nature of its development can be roughly defined into following [4, P. 57]:

1. Unstable (origin and formation of the national vocational education as the education system) – 1924–1940 years;

2. Mobilization (military and post-war period) – 1941–1959 years;
3. Evolutionary (monotonic development) – 1960–1980 years;
4. The pre-crisis (spasmodic development) – 1981–1986 years;
5. Crisis (qualitative changes in development) – 1987–1990 years;
6. Adaptation (stabilization and gradual exit from the crisis) – 1991–1996 years;
7. A new development (implementation of the national model of education) – 1997–2017 years.

One of the distinguishing features of the National model of training is to introduce separate types of education. It was created a new type of educational institutions: academic lyceums and professional colleges, offering the possibility of mastering one or more modern professions and the acquisition-depth theoretical knowledge in different academic disciplines. The choice of the institution of a particular type is free. Moreover, both college high schools gives the right to go on their education in the subsequent education levels [7, P. 65].

As can be seen the main feature of this model – is the continuity of education. That is, a person has the opportunity to acquire knowledge, skills and qualifications throughout his life. This program creates an effective mechanism for the educational system, which has as its main components present respect for the individual, the disclosure of abilities and creativity; the formation of free-thinking man, his moral, physical and spiritual development; progressive training, acquisition of professional skills and a complete personal fulfillment in life. A perfect system of continuous education based on the modern economy, science, culture, engineering and technology is a fundamental precondition for the country's development. This system ensures formation of the new generation of human resources that will be capable of identifying long term objective and effectively achieve them; generation that shows high standards of general culture and professional skills; people that are creative, socially active and able to, independently, appreciate social and political landscape [6, P. 6].

The main objective of the policy of the Japanese government in the field of education was the education and training of creative, original thinking, harmonious and spiritually rich personality, able to operate in a variety

of consolidated public and state structures. In Japan, the first education reform, laid the foundations of its modern appearance, began with the adoption in 1872 of the Basic Education Act. The new system of education, non-estate introduces compulsory training should contribute to the emancipation of the will and initiative of the people, the acceleration of the modernization of Japanese society, as well as – the achievement of proclaimed aim- “enrichment and strengthening of the country [2].”

The history of education can be divided into the following five periods [3, P. 290]:

1. Period base (1868–1885). It was founded the original body education. In June of 1871, it was created the Ministry of Education. In 1872, the Meiji government developed a plan to reform modern school system on a national scale and in August declared the Education Act. The main objectives of this law are:

- Education should ensure the successful advancement of the person on the social ladder;
- Schools function is to instill patriotic feelings of every person;
- All Japanese should learn practical science that ultimately will benefit society and help build a modern state.

2. The period of consolidation (1886–1916). There have been published various law school, established systematic educational structure. In 1885, it was founded cabinet system, was developed the basis for the school system the following periods. None of its major part is not self-sufficient. All components of the system – primary, secondary, vocational, university education – are interconnected. It has formed an educational system that combines loyalty to the monarch with a commitment to free scientific research necessary for the successful establishment and rapid development of Japan as a modern state.

3. The period of expansion (1917–1936). The educational system was based on the recommendations of the Extraordinary Board of Education (1917–1919).

4. War period (1937–1945). The peak of militaristic education. By the early 1930s, in fact the whole process of training and education was controlled by the government. The Ministry of Education, local committees were under the direct control of the Ministry of the Interior, which controlled the whole nation.

5. The modern period (1945 – today). Educational reforms during the Union occupation. The main objective pursued by the occupation authorities, was democratiza-

tion, and demilitarization and decentralization of Japanese society. “Prewar militaristic education was abolished and a new system of education, based on the peaceful democratic tradition has been formed”. Much attention was paid to pre-school education in Japan, because according to psychologists, to seven years a person receives 70% of knowledge and only 30% – for the rest of his life [3, P. 291].

If a few centuries ago, Japan was a-closed country, now it is a powerful state open to the world. That the educational system, which operates in Japan now, developed in 1947 and has undergone during its existence a few reforms, becoming one of the leading in the world. Japanese education system combines the features of the British, American and French educational systems. The education system in Japan in many ways is similar to the education of other western developed countries. Despite that, Japan is characterized by certain features of the education system, which make the country attractive for many people [1, P. 165].

The Japanese educational system achieves amazing results, which are the fruit of the joint efforts of parents, students and teachers. The Japanese education system encourages students to the successful acquisition of knowledge as taught effective methods of development of the material creates a conducive learning atmosphere of the work, helping the integrated education of the individual, directs high school graduates to choose a profession [8]. Japan has a well-developed educational system in which the structure and function has in common with many industrialized countries. However, it is possible to identify some characteristics that are particular to the Japanese system. Professional Education in Diverse Fields to Respond to the Industrial Needs. In contrast to universities and junior colleges, which focus on the theoretic studies, professional training colleges aim is to give useful education in practice. Responding to the needs of the industries, they have established wide-ringed courses. There are quite a few fields where human resource development largely depends on the professional training colleges. The line-up of their curriculums is centered on experiments and practical trainings, and the instructors are well experienced in the real business world. Education for Variety of Professional Qualifications is the Main Pillar. Japanese society is based on “qualifications” and there are a large number of professional qualifications in Japan. Also, the number of various official examinations, which have been

established in order to upgrade. Since professional training colleges aim to respond to the industrial needs, obtaining these qualifications or passing the examinations are one of their main goals. The ministry of labor runs a system of skills tests through its training centers, these are intended to assist the entry of trainees into the labor market, or to support job changes. These examinations are very demanding, and employees are generally expected to invest their own time in preparing for them.

In conclusion, I would like to mention that the country is doing everything possible to ensure that

our children formed a comprehensively developed personalities, able to adapt to life in modern fast-changing society, become worthy citizens of their country, conscious of its responsibility to society, family and government, capable to put and solve new challenges and to adequately continue the deeds of their fathers. As consistently pointed by our President, “In the center of the aspirations of each of us is the dream to raise our children physically and spiritually healthy, nothing and no one is inferior, to see their happiness and prosperous future”.

References:

1. Зверева Н. Н., Муравьёва О. И. Опыт модернизации японской системы образования: история и современность. – URL: <http://cyberleninka.ru/article/n>. – С. 165–170.
2. Общее образования (Япония). Библиотека по педагогике. – URL: <http://pedagogic.ru>.
3. Современная образовательная система в Японии: традиция и тенденции развития. – URL: <http://anthropology.ru>. Hall J. W. Japan: From prehistory to modern times. – New-York. Tuttle Co. – 1995. – 290 p.
4. Толипов Р. Н. Развитие и совершенствование системы среднего- специального образования в Узбекистан // Диссертация. – 1993. – 57 с.
5. Education in Uzbekistan. – URL: <http://www.tashkent.org/uzland/educate.html>.
6. Education for All – 2015 / National Review. – 6 p. – URL: <http://unesdoc.unesco.org>
7. Development of education system in Uzbekistan. Statistical bulletin // 2000–2004. – 65 p. – URL: <http://uzdoc.eu/sites/default/files/development-of-education-system-in-uzbekistan>.
8. Distinctive features of Japanese education system / Reviews of National Policies for Education. – URL: <https://www.nier.go.jp/English/educationjapan>
9. United Nations Development Programme (UNDP). – URL: <http://www.undp.org>

Section 9. Political science

*O'tamurodov Akbar,
doctor, of Philosophy,
Head of Theory and practice of democratic society construction
Department, the Social Sciences Faculty
National University of Uzbekistan,
E-mail: karfagen_87@mail.ru*

THE MAIN STAGES OF THE FORMATION AND DEVELOPMENT OF CIVIL SOCIETY IN UZBEKISTAN

Abstract: In this article, the main stages of the civil society formation and development in the Republic of Uzbekistan.

Keywords: Development Strategy, modernization, civil society, reforms.

Today, in most countries of the world, where the legal democratic system is settled as a combination of universal and national values, it is almost universally acknowledged that the founding of a civil society is the best way to develop a human lifestyle, and its inclining globalization requires the study of civil society as a science.

Our first President, I. A. Karimov, stated, “Our main strategic goal is to be firm and unchangeable, to build a free democratic state based on a market economy, and to build a strong foundation for civil society” [1, 331].

President of the Republic of Uzbekistan Sh. M. Mirziyoyev evaluated the achievements made during the years of independence, “... we will continue to consistently and consistently continue the path of wide-ranging political, economic and social reforms initiated by the first President I. A. Karimov. This path is a solid foundation for building a free, democratic, humane state, building a civil society, raising the economic power of our Homeland and further prosperity” [2].

The notion of civil society is the result of the centuries-long experience of human society, and is defined by the status of human rights and freedoms.

It is well known that in the face of any state and society that has gained its independence, it is necessary to create the concepts of development, which will be able to create the prospects of its development. The develop-

ment model that perfectly reflects the interests and needs of its national development, in the future, will yield its positive outcomes and realize the potential of the nation. From this point of view, on the initiative of I. A. Karimov, the first president, who led the struggle for independence of our state, developed the concepts of strategic development of our state and society. He led the formation of the Republic of Uzbekistan's strategy of independence and progress based on the experience of advanced democratic states and the harmony of national-spiritual traditions.

The main priorities of the ongoing reforms in Uzbekistan are the formation of a civil society in the country. “The Concept for Further Deepening Democratic Reforms and Forming Civil Society in the Country” developed and submitted by I. A. Karimov, at the joint session of the Legislative Chamber and the Senate of the Oliy Majlis on 12 November 2010, was a strategic program of building a new society in the country. It should be noted that this concept proposes the adoption of a number of legal foundations – the adoption of laws for a new society.

The work on the establishment and development of civil society in Uzbekistan can be conditionally divided into four stages: the formation and development of civil society:

The first stage involves the 1991–2000 period. During this period, first, the foundations of the civil society were created.

In the second stage, active processes on democratization and modernization of the country for 2000–2010 were continued.

The third stage is 2011–2016. During this period, the legal basis for the building of civil society was developed, the social supporter of civil society – the middle social layer was further strengthened.

The fourth stage starts in 2017 and is characterized by the practical aspects of the formation of civil society. The idea of building a civil society in this period was further developed in the “Development Strategy” in five priority areas of the Republic of Uzbekistan’s development in 2017–2021 and “The Concept of Administrative Reforms in the Republic of Uzbekistan” and began a radical transformation period in this area. At this stage, civil society developed rapidly and began to show itself in many ways. Meanwhile, the reforms carried out by the President Sh. Mirziyoyev show that the new stage has started.

Uzbekistan has entered the era of modernization of the new era of radical changes and reforms – the end of the second decade of the 21st century – starting from 2017. Developed by the initiative of President Sh. Mirziyoyev the “Development Strategy for 2017–2021”, approved by the President Decree on February 7, 2017, has begun a radical era of development in the country, characteristic of new, developed countries. The program, which is aimed at modernization of all spheres of the society, consists of five directions, which are aimed at modernization in the country, separate regions, different branches and directions in the next five years. It briefly describes the socio-economic, political, cultural, scientific-technical, technological, investment, and modernization of all aspects of society, as well as a “roadmap” for developed countries. The “Development Strategy” also focuses on the development of a clear, realistic, capacity building, and mechanisms for implementation of planned goals and objectives.

Firstly, President Sh. M. Mirziyoyev has developed clear timelines to implement the goals set out in the Decrees and Resolutions. Specifically, the state program adopted in connection with the adoption of the Year of Operation of Innovative Business, Innovative Ideas and Technologies by 2018 sets out key conditions for the implementation of the Development Strategy.

President Sh. Mirziyoyev addressed his appeal to the Oliy Majlis on the following issues on the devel-

opment of civil society and its problems: “The role and place of non-state non-profit organizations in our reforms in building a free civil society, protecting human rights and freedoms it should be emphasized. At present, there are more than 9,000 non-governmental non-profit organizations in the country, and there are 29 international and foreign non-governmental organizations’ branches and representative offices... The decree and decisions aimed at improving the activities of non-government non-profit organizations have been adopted. However, in spite of these important efforts, it is sufficient to systematize the problems of the population, to address them clearly, in particular to support the most vulnerable women, to prevent crime and crime among young people and to ensure their employment is not noticeable. They are only busy attending meetings. We believe that non-government non-profit organizations today can make a breakthrough in their work by drawing conclusions from critical remarks” [3, 34–35].

It is necessary to apply modernization processes in modern Uzbekistan from the point of view of national aspect. For example, the first phase of modernization in Malaysia is a theoretical formulation of the Malaysian development model. The role of government-led development programs in the development of theoretical and practical programming goals of the Malaysian state was remarkable. The “New Economic Policy” program, especially the four-year plans, has played an important role. Additionally, according to Deng Xiaoping, the founder of the modernization in China, the three-stage development strategy envisages joining the Chinese average of 2050 [4]. However, the impact of the strategy adopted in the Republic of Uzbekistan in the global practice, such as the objectives of the development program, the duration of its implementation, and its implementation mechanisms are different: first, the explicit and explicit time-frame of the implementation of the targets, secondly, the pre-establishment of legal and economic foundations for the realization of these goals, the establishment of funding sources for the modernization process, taking into account national conditions in the country, etc. The international community has also been recognized by the “Development Strategy” based on a shorter period of modernization – over five years of its implementation of the expertise of all levels of expertise, its indicators of relevance to the country’s capacities.

Discussion of the “Development Strategy” project by the public and the public over the past few months, taking into account the suggestions and recommendations of scientists, entrepreneurs, farmers, population, and their discussion in the labor collectives has played an important role in improving the legal and political awareness of our people. These measures, in turn, have helped improve the project, taking into account the real needs and needs of the population. In other words, the modernization process in our country has been reflected not only on foreign experiences, but also in the “Development Strategy”, which is based on the needs of the national traditions, the challenges posed by their solutions, and the need for reform. The “Development Strategy” project passed on “public expertise” and public debates on TV, radio and the Internet.

At the present time, the implementation of the “Development Strategy” positively influences the development of all sectors of the society, including laws, presidential decrees, resolutions, government decisions, and the results of their implementation. This means that the tasks in the “Development Strategy” are gradually being implemented. In this process, the President’s vertical lobby and the People’s Deposits are doing important work for the reform. They are working on solving problems, creating conditions for development based on their applications, applications and suggestions.

Monitoring the implementation of the goals and objectives of the “Development Strategy”, the adoption and implementation of the state program for the development of a key sector every year necessarily involves coordination and analysis of this process. This objective requires the establishment of analytical centers. Given the international experience, we see the sights of new developments in this area. In particular, the Center for Modernization Studies under the Academy of Sciences of China operates. This

research center is engaged in the implementation of the monitoring of the processes of modernization, the development of strategic programs that define the prospects of their publication and modernization. Such centers are available in all developed countries. The Development Strategy Center was established in Uzbekistan on February 23, 2017. Its main tasks are:

- request and receive required statutory, statistical and analytical information from ministries, departments, banks and other organizations within their mandate;
- submission to expert groups to be established by the commissions on the drafting of draft documents envisaged by the Program;
- engaging on a contractual basis as experts from public administration bodies, agencies, banks, academics and researchers from research and higher education institutions, independent experts, including foreign governments;
- to determine the right of coordination of invited national and foreign experts for development of measures on implementation of the Development Strategy [5].

In general, in the current “Development Strategy” was recognized as a national model of development and recognized by international organizations. Modernization in any country in the world of experimental theories and models of modernization theories and models is rarely found in the development model, which covers all spheres of the society, giving its effect in the short run. From this point of view, Uzbekistan has long been recognized by developed state and international organizations in decades as decentralization of the public administration, liberalization of the economy, creating favorable legal and financial conditions for the social layer of the proprietor, encouraging innovation and investment in the country began to show itself. Of course, this means that our state is actively pursuing civil society.

References:

1. Karimov I. A. Ozod va obod Vatan, ehrkin va farovon xayot – pirovard maqsadimiz. T.: Ўzbekiston.– 2000. 8-zhild.
2. Mirziyoev Sh. M. Erkin va farovon, demokratik Ўzbekiston davlatini mard va olizhanob halkimiz bilan birga quramiz. Ўzbekiston Respublikasi Prezidenti Shavkat Mirziyoevning Ўzbekiston Respublikasi Olij Mazhlis Qonunchilik palatasi va Senatidagi nutqi. Halk sʻyzi. 15.12.2016.
3. Mirziyoev Sh. M. Olij Mazhlisga Murozhaatnomasi.– T.: Ўzbekiston,– 2018.
4. Deng Xiaoping. Selected Works of Deng Xiaoping. – Vol. 3. Beijing: People Press.– 1993.
5. URL: http://www.lex.uz/pages/getpage.aspx?lact_id=3114480&twolang=true

Section 10. Agriculture

*Zhurlov Oleg Sergeevich,
Institute for Cellular and Intracellular Symbiosis,
Ural Branch Russian Academy of Sciences,
Orenburg, Russia
E-mail: jurlov1968@mail.ru*

*Grudinin Dmitriy Aleksandrovich,
Institute of Steppe,
Ural Branch Russian Academy of Sciences,
Orenburg, Russia
E-mail: grudininda@yandex.ru*

*Mushinskiy Alexandr Alekseevich,
Institute for Cellular and Intracellular Symbiosis,
Ural Branch Russian Academy of Sciences,
Orenburg, Russia
E-mail: SAN2127@yandex.ru*

*Yakovlev Ilya Gennadievich,
Institute of Steppe,
Ural Branch Russian Academy of Sciences,
Orenburg, Russia
E-mail: russo-turisto01@yandex.ru*

METHODOLOGICAL APPROACHES TO MONITORING MICROBIAL COMMUNITIES OF AGRICULTURAL LANDSCAPE OF THE STEPPE ZONE

Abstract: The article analyzes the methodological features of sampling soil for agrochemical, microbiological and metagenomic analysis. The possibility of integrating soil sampling methods on the basis method for sampling soil from equidistant points with GPS positioning is discussed, as a single methodical technique, most accurately reflecting the features of the distribution of physical and chemical properties and microbial communities of soil. Standardization of soil sampling methods for physicochemical, microbiological and metagenomic research is necessary for the construction of a GIS “Microbial communities of agricultural landscape”.

Keywords: agroecology, bacterial communities, agricultural landscape, geographic information system (GIS).

Introduction

Methodological development of issues of increasing soil fertility, the effectiveness of “self-restoration” and re-cultivation of agricultural landscape, are an actual task of agroecology.

Microorganisms of the soil are the main destructors of organic matter and promote the transfer of nutrients in form that is accessible to plants. They have a dominant role in the processes of mineralization and humification of plant residues in the soil.

One of the main tasks contributing to the increase of soil fertility is the conservation and effective regulation of the qualitative composition of microbial communities of agricultural landscape. Microbial succession, under the influence of external and internal environmental factors, is the main reason for the change in the composition of microbial communities of agricultural landscape and natural landscapes.

Therefore, the development of a system of geoinformation mapping of microbial communities will help control their changes under the influence of biotic and abiotic factors.

Development of methodological foundations of phylogenetic mapping of microbial communities of soils will contribute to the effectiveness of recultivation of agricultural lands and restoration of natural landscapes.

Monitoring the physicochemical parameters of soil

The lack of unified requirements for soil sampling for agrochemical, microbiological and metagenomic analysis does not allow analyzing the totality of soil «health» indicators. Today, for the sampling of soil, accredited organizations use several techniques [1, 2, 3, 4]. Often, the territory under investigation is not homogeneous. Features of microrelief and soil mosaic affect the distribution of vegetation and microbial communities of soil [5].

The methods used average the physicochemical parameters of soil samples taken in different parts of the field, smoothing out this heterogeneity. This approach is dictated by the “old” labor-consuming methods of research and analysis of a typical “dominant” in the study of the physical and chemical properties of the soil, which are extrapolated over the entire area of the investigated soil region. Modern methods of soil analysis are more economical, both from the point of view of the use of time, the amount of material taken, and the reagents used.

Paradoxically, until now there is no method that would meet the requirements of sampling automation for a number of physical and chemical properties of the soil and showed physicochemical parameters in a certain sector of the field.

The standardization of soil sampling techniques and their integration into a single methodical technique will allow in the future carrying out complex monitoring studies of the chemical composition and microbial

communities of soils. The most popular method of sampling in soil science and agrochemistry is the «konvert» method [6].

However, it does not take into account the sterility of the soil sample, it is impossible to determine the thickness of the layer of the soil horizon, an average sample (total sample) is selected. According to the results of agrochemical and microbiological analysis, it is impossible to compare the actual distribution of microbial communities depending on the agrochemical indicators of the soil.

Moreover, the features of soil sampling of the agricultural landscape and natural landscapes associated with the formation of monitoring sites are not suitable for soils in urban areas. The presence of communications, anthropogenically-modified horizons makes it impossible to form stationary sites in urban areas.

Therefore, it is necessary to develop a single method for sampling soil for physicochemical, microbiological and metagenomic analysis.

Monitoring of microbial communities

An important factor for constructing a geoinformation system for phylogenetic mapping of microbial communities will be the effectiveness of soil sampling.

Today, in agricultural microbiology, the basic approaches to the determination of microbial communities of soils have changed. Whereas earlier “cup” methods were used to estimate the number of cultivated groups of microorganisms by seeding on selective nutrient media [4], today, with the development of modern methods of molecular genetics sequencing, approaches to soil sampling have changed [7].

This led to revolutionary changes in the study of the metagenome of microbiological communities of soils and contributed to the development of a new trend in molecular genetic studies-comparative metagenomics. Modeling the links between microorganisms using bioinformatic analysis methods often involves a hypothetical nature of the relationship, which does not allow evaluating the relationship between microorganisms in the microbial community.

The method of sampling for metagenomic research does not take into account the features of the landscape relief, the sampling points of the soil are empirically selected, and the soil samples are mixed with the formation of a common sample. Such studies do not take into

account seasonal changes in the qualitative composition of microbial communities associated with changes in temperature and soil moisture.

So, as a result of studies of the soil microbiome by molecular genetic methods it was found that the proportion of cultivated bacteria is less than 1% of the composition of microbial communities of soils. Uneven distribution of pH, soil moisture, vegetation cover lead to the creation of “biogeographic patterns” [8], the formation of the biotic nuclei of the ecosystem, which are sources of distribution of microbial communities. Interpretation of metagenomic data is problematic, because often the complex composition of microbial communities varies in time and space [9].

Today, as a result of high-throughput sequencing of 16S-rRNA gene libraries, the main taxa of microorganisms forming microbial soil communities are known – α -Proteobacteria, Actinobacteria, Acidobacteria, Verrucomicrobia, Bacteroidetes, Firmicutes, Gemmatimonadetes, Chloroflexi [10]. It was also shown that the composition of microbial communities strongly depends on two physicochemical parameters of the soil (soil moisture and pH). In arid regions, actinobacteria predominate and in water-saturated proteobacteria.

Undoubtedly, they form the main part of microbial communities of soils, but the most variable part is represented by poorly represented taxa whose qualitative composition is influenced by both internal and external environmental factors. Analysis of the composition of microbial communities of different types of soils, based on the results of microbiological and metagenomic analyzes, makes it possible to identify ecological-trophic groups of microorganisms and to carry out their further monitoring.

The method of phylogenetic mapping of microbial communities proposed by us is that soil sampling is performed at grid sites with a 25-meter cell centered at the GPS positioning point. Sampling soil is made to a depth of 20 cm sterile aluminum cylinders. Point samples are not combined and characterize the distribution of microbial communities throughout the topsoil (organic and organo-mineral horizons). The systematization of metagenomic analysis data with GPS positioning will allow not only to characterize microbial communities located at equidistant points, but also to determine the boundaries of their distribution. The creation of

GIS “microbial soil communities” will allow to identify phytopathogenic microorganisms and, when developing appropriate methods, to monitoring the content of harmful substances in the soil. No less important is the development of the direction associated with microorganisms-biosensors of physical and chemical properties of soils. Shifting the qualitative composition of microbial communities can be used as an indicator of the ecological state of agricultural landscape.

Hence, each point sample of the soil characterizes the state of physicochemical parameters in a certain sector of the field, and the number of sectors with similar characteristics reflects the diversity of the distribution of not only the physicochemical parameters, but also the differences in the composition of microbial communities in each sector of the field. The formation of a general sample in the selection of samples with “standard” methods of metagenomic analysis contributes to an increase in the proportion of “dominant” and a decrease in the share of “minor” taxa, which may lead to a shift in the distribution of microbial communities in the field region and does not allow analysis of the distribution of microbial communities along the gradient of physico-chemical soil indicators.

Conclusions

First, the creation of methodological bases for phylogenetic mapping of microbial communities of soils will allow monitoring of the composition of microbial communities, the spread of phytopathogenic microorganisms and their regulation.

Secondly, based on the results of monitoring the phylogenetic composition of microbial communities of agricultural landscape, it will be possible to develop scientifically grounded recommendations on the rational use of organic and mineral fertilizers.

Thirdly, the standardization of the soil sampling methodology for agrochemical, microbiological and metagenomic analysis will allow us to compare the results of analyzes obtained by other researchers and to assess the effect of a complex of factors on the fertility of the soils of the agricultural landscape.

The reported research was funded by Russian Foundation for Basic Research and the government of the region of the Russian Federation, grant № 17–44–560976.

References:

1. Arinushkina E. V. Guidelines for the chemical analysis of soils.– Moscow: Moscow State University,– 1970.– 487 p.
2. GOST 17.4.3.01–83. (ST SEV 3847–82). Protection of Nature. Soil. General requirements for sampling. Enter. from 01.07.84 to 01.01.89.– Moscow: Publishing Standards,– 1983.– 2 p.
3. GOST 17.4.4.02–84. Protection of Nature. Soil. Methods of selection and preparation of samples for chemical, bacteriological, helminthological analysis. Enter. from 01/01/86.– Moscow: Publishing Standards,– 1984.– 15 p.
4. Methods of soil microbiology and biochemistry. Edited by D. G. Zvyagintseva.– M.– 1991.– 303 p.
5. Dobrovolskaya T. G., Golovchenko A. V., Pankratov T. A., Lysak L. V., Zvyagintsev D. G. Assessment of bacterial diversity of soils: the evolution of approaches and methods. Soil Science.– 2009.– No. 10.– P. 1222–1232.
6. Methodological recommendations sampling of soils, soils, bottom sediments, silt, sewage sludge, industrial sewage sludge, production and consumption wastes. PND F 12.1: 2: 2: 2: 2.3: 3.2–03.– Moscow,– 2014.
7. Andronov E. E., Pinaev A. G., Pershina E. V., Chizhevskaya E. P. DNA isolation from soil samples (methodical instructions). SPb: ARRIAM RAAS.– 2011.– 27 p.
8. Fierer N., Morse J. L., Berthrong S. T. et al. Environmental controls on the landscape–scale biogeography of stream bacterial communities. Ecology.– 2007.– Vol. 88.– P. 2162–2173.
9. Ebrahimi A., Or D. Microbial community dynamics in soil aggregates shape biogeochemical gas fluxes from soil profiles – upscaling an aggregate biophysical model. Glob Chang Biol.– 2016. – Vol. 22.– P. 3141–3156. URL: <http://dx.doi.org/10.1111/gcb.13345>
10. Lauber C. L., Strickland M. S., Bradford M. A., Fierer N. The influence of soil properties on the structure of the bacterial and fungal communities across land–use types. Soil Biol. Biochem.– 2008.– Vol. 40.– P. 2407–2415. URL: <http://dx.doi.org/10.1016/j.soilbio.2008.05.021>

Section 11. Technical science

*Alikulov Shuxrat Sharofovich,
E-mail: sharofovich@mail.ru*

THE RESEARCH OF INTENSIFICATION OF THE TECHNOLOGICAL PROCESSES OF IN SITU LEACHING OF URANIUM

Abstract: In this paper, we present the simulation based on the 3D MAX program. The simulated pilot plant is located on the block of the field. The site includes nine technological wells (six injection and three productive) with vertical extended collectors. The simulated site is confined to the central part of the productive horizon, the sole of which lies at a depth of 95–97 m, the upper and lower waterproof are sustained, lithological windows are absent. In the process of modeling, the structure of the underground flow of solutions was studied, which is formed when long collectors of various lengths and permeability are involved in operation. The hydrodynamic flow pattern obtained within the experimental-industrial sector, obtained as a result of the solution of the initial variant, showed the symmetric propagation of solutions over single hydrodynamic cells of the field.

Keywords: Collector, uranium leaching, modeling, filtration coefficient, depth of ore body, productive horizon.

A general analysis of the consequences of the use of vertical extended collectors was carried out in the work. Estimation of the influence of the length (longitude) and the degree of reservoir permeability on the main geotech-

nological indicators of working off for the field conditions was carried out experimentally by modeling. Seven basic variants of the problem interrelated with the length and permeability of the reservoir are shown in Table 1.

Table 1. – The basic variants of modeling of ISL systems with vertical collectors

Permeability, m / day	Length of long reservoir, m (%)		
	5.2 (20)	11.6(46)	25.0(100)
144	I	II	III
280	IV	V	VI
The initial version – without extended collectors			

The coefficient of filtration of the aggregate of the extended collector (granulated polyethylene) is determined on the KF-OOM instrument in the chemical and soil science laboratory of the enterprise. Based on the simulation results, hydrodynamic flow networks formed under the influence of extended collectors are constructed, calculations of the acidification time and the time of the single hydrodynamic cell recovery, as well as the reagent consumption and the average concentration of the useful component in the productive solutions are performed.

Initial data and modeling procedure

In this paper, we present the simulation based on the 3D MAX program. The simulated pilot plant is located on the block of the field. The site includes nine technological wells (six injection and three productive) with vertical extended collectors. The simulated site is confined to the central part of the productive horizon, the sole of which lies at a depth of 95–97 m, the upper and lower water bodies are sustained, lithological windows are absent. The waters of the pressure horizon, the depth

of piezometric level from 48–57 m (in the north) to the self-discharge (in the south), the head above the roof increases in the same direction from 35–50 to 130–140 m. The water-bearing rocks are sandy-clay sediments with the filtration coefficient is 4–12 m/day. The thickness of the horizon, varying from 6.5–7.5 m on the left flank of the section to 4.5 m on the right, is identical for each group of three wells that form elementary hydrodynamic cells. The water content of the rocks, according to experimental data, varies from 1.2 to 5.6 l/s with a decrease in the level of 1.63–8.34 m. Specific well rates are 0.26–1.28 l/s. The rate of self-depreciation varies from 1.8 l/s at the self-ejection boundary to 50–72 l/s in the southeastern part of the horizon.

When the natural situation is schematized, the following average values for the parameters are adopted: the dimensions of a single hydrodynamic cell are 25 × 45 m, the productive horizon is 6 m, the filtration rate is 8 m/day, the technological wells depending on their location in the reservoir are 25.50 and 100 m³/day. The calculated filtering resistances were transferred by means of scaling factors to electric ones, which were typed on the grids of the electro-integrator connected in the planning model. The change in permeability in the specification of extended collectors was taken into account by recalculation and replacement of the corresponding resistances in the range of the collector. Connections of electrical potentials: in the initial version without extended collectors in all nodes of the model to estimate the possible influence of boundary conditions with respect to a single hydrodynamic cell, in other variants only for a calculated unit cell.

The potentials obtained were used to construct hydrodynamic grids and subsequent calculations of the time and rate of acidification. The reliability of the measured electrical parameters was ensured by the balance sheet specification of the boundary conditions of the second kind, and the accuracy was verified by balance calculations according to Kirchhoff's law for electric circuits (according to the variant with self-distribution of the flow through the perfect gallery).

In the process of modeling, the structure of the underground flow of solutions was studied, which is formed when long collectors of various lengths and permeability are involved in operation. The hydrodynamic flow pattern obtained within the experimental-industrial sector, obtained as a result of the solution of the initial variant,

showed the symmetric propagation of solutions over single hydrodynamic cells of the field. Therefore, for convenience in calculating the indicators, a half-cell with dimensions of 12.5 × 45 m is adopted.

The time of advance of solutions between technological wells was calculated by the finite-difference method with the help of the known dependence (1) on the main current strips isolated on hydrodynamic grids, taking into account the self-distribution of flow along the length of the extended collector

$$t_i = \frac{P_{ef}}{K} \sum_{i=0}^n \frac{\Delta l_i^2}{\Delta U_i} \quad (1)$$

where P_{ef} – Effective porosity of the formation in fractions of unity, assumed to be 0.2;

K – coefficient of filtration, m/day;

l_i is the distance between neighboring equipotentials of a given current tape, m;

U_i – difference of potentials on the current tape section of length m;

n – is the number of cells in the current ribbon.

The construction of the current tapes was determined by the condition of equal costs for each of them from extended collectors $QnT = 6.25 \text{ m}^3/\text{day}$ (0.25 mA). For the calculation of geotechnological indicators, a uniform distribution of the reserves of the useful component in the semi-cell was adopted. Thus, the time of working out the half-cell for 80% of extraction of its reserves is determined by the formula:

$$T_{80\%} = N \cdot t \quad (2)$$

Calculation of the specific consumption of the reagent per unit mass of the extracted useful component is carried out by the formula

$$K = \frac{\bar{C} \cdot Q \cdot T_{80\%}}{P_{80\%}} \quad (3)$$

Where \bar{C} is the average concentration of the reagent taken 10 g/L;

Q – flow of a technological well entering the half-cell and equal to 50 m³/day, %.

P – recoverable cell stocks.

The average concentration (content) of a useful component in productive solutions is determined by the formula

$$\bar{C} = \frac{P_{80\%}}{Q \cdot T_{80\%}} \quad (4)$$

The time of distribution of solutions is the most important geotechnological indicator characterizing the acidification and elaboration of the productive horizon.

In any cell in the reservoir, the solution moves with maximum velocities along the shortest current bands between the production wells, which occurs under the influence of the largest pressure gradients acting in this direction.

The remoteness of the working parts of the wells from the boundaries of the formation (cells) and the associated spreading of solutions leads to their dilution, uneven processing of the formation, and the formation of so-called stagnant zones, the motion in which almost does not occur, which excludes such zones from the field of operation.

Optimal cases – perfect galleries that connect wells in pumping and casting rows – are technically impossible. Therefore, extended reservoirs make it possible to approximate, to a certain extent, the problem of uniform development of reservoir deposits.

At the same time, collector cavities that are ideal in size (length and width) and permeability can not be created practically. Under real conditions, unpredictable deviations of the design parameters of extended collectors will always occur, due to the inconsistency of their dimensions and the inability to achieve uniform permeability.

In connection with some conditionally accepted initial indicators ($P_{80\%} = 400\text{kg}$, $N = 8$, $C = 10\text{g/l}$), it is more convenient to perform a comparative evaluation of the obtained dependencies in relative units, taking as a basis the parameters of the initial variant (without extended collectors).

The purpose of pilot-industrial works on the construction of sites with extended collectors is the creation and development of technology and technical equipment for the construction of extended collectors, the development of a PW system with vertical extended collectors in the ranks of technological wells.

The main tasks of pilot industrial works are:

- construction of special wells for collectors;
- the use of granulated polyethylene as a filter material as inert to the action of sulfuric acid and having a positive buoyancy of the material, which does not require the use of highly viscous liquids for the delivery of materials with high specific gravity to the collector wings;
- determination of parameters of the process of occurrence of zones of increased permeability and modes of basic technological processes.

To predict the fracture pressure parameters, the following problem was theoretically solved: a liquid was pumped into the array through vertical slits at a pressure p .

In the polar coordinate system (r, β) , the distribution of radial, tangential and tangential stresses is:

$$G_{rr} = G_{cr} \left[1 - \left(\frac{r_0}{r} \right)^2 \right] + C_0 \left(\frac{r_0}{r} \right)^2 + 2 \sum_2^{\infty} C_n \left(\frac{r_0}{r} \right)^n \cos n\beta + \left[1 - \left(\frac{r_0}{r} \right)^2 \right] \sum_2^{\infty} n C_n \left(\frac{r_0}{r} \right)^n \cos n\beta \quad (5)$$

$$G_{\beta\beta} = G_{cr} \left[1 + \left(\frac{r_0}{r} \right)^2 \right] - C_0 \left(\frac{r_0}{r} \right)^2 + 2 \sum_2^{\infty} C_n \left(\frac{r_0}{r} \right)^n \cos n\beta - \left[1 - \left(\frac{r_0}{r} \right)^2 \right] \sum_2^{\infty} n C_n \left(\frac{r_0}{r} \right)^n \cos n\beta \quad (6)$$

$$G_{r\beta} = \left[1 - \left(\frac{r_0}{r} \right)^2 \right] \sum_2^{\infty} n C_n \left(\frac{r_0}{r} \right)^n \sin n\beta \quad (7)$$

Where

$C_{cr} = \lambda\gamma H$ – lateral mountain pressure;

r_0 – is the radius of the well;

r – distance from the well axis;

β – polar angle;

G_{rr} , $G_{\beta\beta}$ – normal radial and tangential stresses;

$G_{r\beta}$ – tangential stresses;

half the angle of the slit solution;

coefficient of lateral rock rupture;

H – is the depth of the processing interval.

Knowing the stress distribution in the array, you can determine

$$G_{1,2} = \frac{G_{rr} + G_{\beta\beta}}{2} \pm \sqrt{\left(\frac{G_{rr} - G_{\beta\beta}}{2} \right)^2 + G_{r\beta}^2} \quad (8)$$

To determine the critical burst pressure, the following criterion was chosen:

$$(G_{\max} - G_{\min})^2 + 8T_0(G_{\max} + G_{\min}) = 0 \quad (9)$$

$$\text{If, } 3G_{\min} + G_{\max} > 0,$$

$$\text{And, } G_{\min} = T_0, \text{ if } 3G_{\min} + G_{\max} > 0,$$

Where G_{\max} – is the maximum principal stress;

G_{\min} – is the minimum principal stress;

T_0 – critical tensile strength.

Thus, if the above identities are observed at the points of the array, a disturbance of the mountain mass will occur.

The solution was processed using Matlab calculations. The corresponding program was compiled and the

destructive functions ψ were calculated by the formula (9) The results of the calculation of the fracture function ψ are given in the application in place with the program with the following input data: $G_{cr} = 0,93MIIa$, $\alpha_0 = 0,3125pad$; $T_0 = 2,25MIIa$; $p_0 = 4,0;5,0$ and $6,0MIIa$.

Isolines were constructed for selective modules of the fracture function. (In Fig. 1). The isolines are shown $\psi = -0.51, -1.05, -2.13k, -2.44$ (blue color)

at a discharge pressure of 4.0 MPa. The minus sign in this case indicates that the rock of the surrounding massif is in the precritical state of equilibrium. As can be seen from the figure, as we approach the walls of the well ψ , it tends moderately to zero, that is, to a state of discontinuity. On the wall of the borehole, on the median axis, the function takes its minimum value for a pressure of 4.0 MPa and is equal to -0.51 , which is very close to zero.

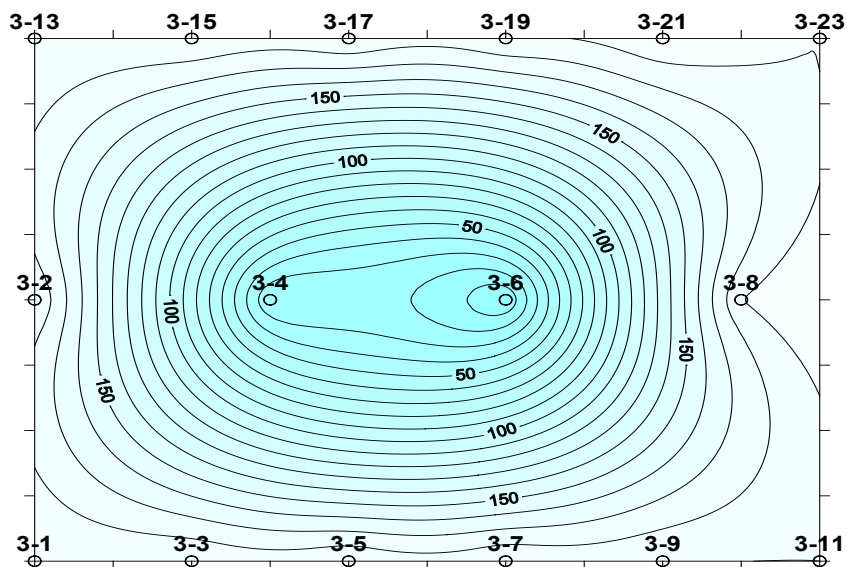

Figure 1. Ways to spread the solutions of underground uranium leaching

But, nevertheless, the destruction of the array is not yet taking place. With a pressure increase up to 5.0 MPa, a point appears on the wall of the well, the coordinates of which $(r_0, 0)$ already with a positive value close to zero of 0.15 of the fracture function ψ (red dot). This indicates that at p_0 4.8–5.0 MPa on the borehole wall on an axis with an angle of 0° , with the orientation of the slits adopted in the figure, a fracture surface or fracture of fracture appears. And, finally, in Fig. 1. At pressures of 6.0 MPa, the fracture surface encompasses a significant zone approximately equal to the size of the semicircle with a radius $(1.3-1.4) r_0$, where r_0 is the radius of the borehole. In this pressure range (5.0–6.0 MPa), the cavity begins to develop rapidly and a main crack is formed in

the massif, as a result of which the pressure at the bottom sharply decreases. Thus, for a given type of impact on the face and with the accepted strength characteristics of the surrounding rocks, the fracture in the massif starts to appear at a critical burst pressure of about 5.0 MPa, which is consistent with the experiment carried out at the well where the fracture pressure was 5.0 MPa.

With increasing strength characteristics of rocks, namely the critical tensile stress $T_0 = 5.7$ MPa, which is typical for cement stone formed as a result of long downtime, the pattern of isolines for the failure function is identical to the isolines in (Fig. 1). For pressures up to 10.5 MPa. And only at a pressure of 11.0 MPa in the cement stone will develop a crack that will destroy it.

References:

1. Grabovnikov V.A. Geotechnological calculations and studies in the exploration of metal deposits for underground leaching / OCNTI VIEMS.– M.,– 1978.
2. Istomin V.P. Features of the mineral and raw materials base and the prospects for uranium mining in the mine No. 5. Mountain Herald of Uzbekistan – No. 4.– 2003.– P. 67–68.

3. Kalabin A. I. Extraction of minerals by underground leaching and other geotechnological methods. –M.: Atomizdat. – 1981.
4. Kashe M. N. Investigation of hydrodynamic and hydrochemical regimes of underground leaching processes for determination of technological parameters Abstract of Cand. Thesis – M. MGRI, – 1974.

*Arifjanov Aybek Mukhamedjanovich,
doctor, of technical sciences, professor,
Head of the Department of Hydraulics and Hydroinformatics,
Tashkent Institute of Irrigation and Agricultural Mechanization Engineers
E-mail: obi-life@mail.ru*

*Akmalov Shamshodbek Bakhtiyarovich,
doctoral, researcher of Tashkent Institute of Irrigation
and Agricultural Mechanization Engineers,
Department of Hydrology and Hydrogeology
E-mail: shamshodbekjon@mail.ru*

*Samiev Luqmon Nayimovich,
Senior researcher, Department of Hydraulics and Hydroinformatics,
Tashkent Institute of Irrigation and
Agricultural Mechanization Engineers.
E-mail: luqmonsamiev@mail.ru*

*Tursunoy Ubaydullaevna Apakxo'jaeva,
assistant, Department of Hydraulics and Hydroinformatics,
Tashkent Institute of Irrigation and
Agricultural Mechanization Engineers*

CHOOSING AN OPTIMAL METHOD OF WATER EXTRACTION FOR ARID REGIONS IN THE CASE OF BESHBULAK AND YANGIOBOD VILLAGES (SYRDARYA PROVINCE, UZBEKISTAN)

Abstract: This article is about choosing an optimal method of water extraction in arid areas. Water is a very important asset in arid areas. In order to control water allocation, specialists need fast and accurate information about water objects and irrigation sets. Remote sensing data are a useful tool for this. Many researchers have used these data with satisfying results. With remote sensing data a lot of methods and ways to extract water objects have been created. Choosing a more effective method has been an important goal for researches. In our paper a lot of water extraction methods are compared in the Beshbulak and the Yangiobod region. According to the results, the most accurate method of water extraction for arid zones is chosen. This method is water objects extracting with the NIR2 (near infrared) band of VHR (very high resolution) data.

Keywords: NDWI (normalized difference of water index), RS (remote sensing), Water management, object based image analysis (OBIA), eCognition, Arid regions.

1. Introduction

Water extraction is very important for water accounting system. 10 years ago the VHR remote sensor was created. It has a connection with IKONOS and QuickBird satellites' launches. Afterwards, more developed satellites were launched [6]. The development in RS was the reason to use this information more widely in water management. Since 2000 the usage of RS in

water management has increased sharply. RS systems have been developing and launching different satellites with various possibilities. Water objects and irrigation sets of the country in small areas have been enlarged by the spectral resolution of satellite sensors, enabling analysis of irrigation sets on land. Main objective of this research to choose optimal index of water extraction for arid zone.

Water extraction methods. For water extraction used different indexes which created in different years by different scientists and different bands of satellites. They are:

$$\text{McFeeters' [5] index} - \text{NDWI}_M = \frac{(G - \text{NIR})}{(G + \text{NIR})} \quad (1)$$

There: G-green band of satellite images, NIR-Near infrared band of satellite images.

$$\text{Wolf et al., [7]; [8] index} - \text{NDWI}_W = \frac{(C - \text{NIR2})}{(C + \text{NIR2})} \quad (2)$$

There: C – coastal band of satellite images, NIR2–2nd near infrared band of satellite images.

$$\text{Chen et al. [1]} - \text{NDWI}_{Ch} = \frac{(G - \text{NIR2})}{(G + \text{NIR2})} \quad (3)$$

$$\text{Jawak \& Luis [3] [4] index} - \text{NDWI}_{J1} = \frac{(C - \text{NIR1})}{(C + \text{NIR1})} \quad (4)$$

$$\text{NDWI}_{J2} = \frac{(B - \text{NIR1})}{(B + \text{NIR1})} \quad (5)$$

$$\text{NDWI}_{J3} = \frac{(B - \text{NIR2})}{(B + \text{NIR2})} \quad (6)$$

There: B-blue band of satellite images.

2. Method and materials

Case of study. The research areas are Beshbulak and Yangiobod villages which are situated in Syr-Darya Province, Uzbekistan.

Field data collection. It is obligatory to point out the appropriate method among them with the best results to classify the water objects in the province at present and in the future. It guarantees the creation of a useful method for specialists to observe the water objects. Thus, it is necessary to compare the water objects in WV2 trapezium in field experiments for validation. To realize this comparison, one needs to collect data about features of water objects. Taking this need into account, we have taken the information about water objects' location; their size and width in the WV2 trapezium.

Satellite data collection. From RS data for water extraction analysis used WorldView-2 satellite data. For irrigation set extraction analysis we have chosen two zones. The first zone is well supplied with water WV2–2011 (Beshbulak vilage) and the second one is desert zone which has some problems with water supply WV2–2012 (Yangiobod village) (Tab. 1):

Table 1.– List of collected WordView-2 data and their technical characteristics (Source: digitalglobe.com 2014)

Collected data (WorldView-2 (Q3–09))						
ID	Year	Month	Date	Latitude	Longitude	Cloud cover
WV2–2011 (Beshbulak village)	2011	07	21	40.501	69.05	0
WV2–2012 (Yangiobod village)	2012	09	12	40.481	68.729	1

Segmentation analysis. After numbers of segmentation analyses, we have chosen the following optimal parameters for segmentation of WV images (Tab. 2):

Table 2.– Segmentation parameters for WV2 data

Satellite name	Image layers	Image Layer weights	Scale parameter	Shape	Compactness
WV2–2011 (Beshbulak village) WV2–2012 (Yangiobod village)	Pan	3	50.75	0.2	0.9
	Costal	3			
	Blue	2			
	Green	2			
	Red	2			
	NIR	2			
	NIR2	2			
	Red edge	1			
Yellow	1				

Homogeneous objects nearby the river are larger in segmentation of the image, so we have set $SP=250$ for Quandtree based segmentation. After the segmentation, small segment objects ($\leq 256 p \times l$) and objects with $NIR < 120$ have been classified into “watery objects”, and the others into “other objects”.

In the next step, watery objects were segmented with the algorithm “multiresolution segmentation region grow”, the scale parameter has been increased until the creation of a homogeneous object and optimal parameter scale above had been chosen (Tab. 2). The reason of choosing a small scale parameter for the growth algorithm is the covering of water bodies with strong coastal vegetation in this area. And it becomes difficult to separate the coastal vegetation in segmentation. That is why

we have chosen a small parameter. And now, the second step is the classification process.

Classification. In this step we used assign class and merge region algorithms. In analysis it is seen that high reflectance objects prevent the determination of water objects when using NDWI. For this reason, the first step must be the classification of these objects into “high reflectance”. Most high reflectance objects are artificial areas. This situation we can see in a lot of similar analyses. In other words, in our analysis the most effective layer was coastal bands to determine “high reflectance” objects. We used DN indices of this band for determining open ground, ground ways, buildings and asphalt roads, as well. Consequently, coastal band is the most suitable band for classifications of asphalt ground roads and population centers (Tab. 3).

Table 3.– Classification value of urban areas for WV2 data

Satellite name	IF	THEN	ELSE
	Coastal		
WV2–2011 (Beshbulak village)	≥ 417	Roads and urban areas	Unclassified
WV2–2012 (Yangiobod village)	≥ 349		

Water bodies and irrigation sets. The use of the above mentioned formulas for NDWI calculation in WV2 images analysis in different conditions has given positive results. We used “water object classification with WV2

image analysis” from all these formulas and we evaluated the effectiveness of this formula (1)-(6). Besides, we used different bands of images for water extraction (Tab. 4).

Table 4.– Classification value of water objects for WV2 data.

Satellite name	IF				THEN	ELSE	
	NIR	NIR2	Pan	RedEdge			
WV2–2011	≤ 260	≤ 430	≤ 278	≤ 360	Water bodies and irrigation sets	Unclassified	
WV2–2012	≤ 440	≤ 420	≤ 237	≤ 420			
	Brightness	NDVI	$NDWI_w$	$NDWI_{ch}$			$NDWI_{j3}$
WV2–2011	≤ 292	$\leq 0,09$	≥ 0	≥ 0			≥ -0.1
WV2–2012	≤ 325	$\leq 0,18$	≥ -0.1	≥ -0.05			≥ -0.18
	$NDWI_{j1}$	$NDWI_{j2}$	$NDWI_M$				
WV2–2011	$\geq 0,13$	≥ 0	≥ 0.1				
WV2–2012	$\geq 0,12$	≥ 0.2	≥ -0.06				

The accuracy of the results have been tested by classification accuracy

3. Results

Classification accuracy. For the classification accuracy checks were created in water objects shape file by using GIS and GPS in the research area (Fig.1).

Observations showed that the desert area consists of two water objects (lakes) and 19 irrigation sets. Only two of the investigated irrigation branches are

more than 10 meters width (main channels), the rest of the canals` width is 4–5 meters and a lot of other channels have a width of less than four meters. On the coastal area of the river we have found four water objects, one of them is a river that divides 21 irrigation sets. Four branches out of those are of 10 meters width (Fig. 1).

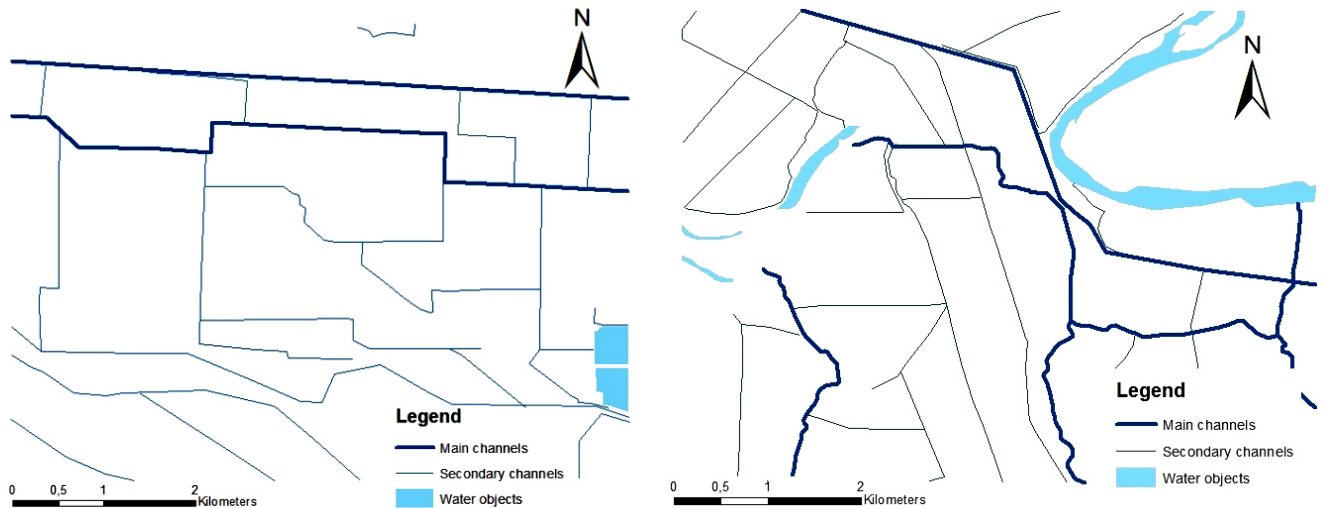

Figure 1. Created water sets and object map for Yangiobod and Beshbulak villages (source Akmalov)

Classification results. The smallest value of the near infrared band of the WV2 satellite gave us water objects. Because of this band we could extract large water objects and big water branches. In both analyses large water objects are fully determined. As Beshbulak village is located on the coastal area and as its main agricultural planting is rice growing, water full rice fields are also classified into water objects. That is why the map contains a lot of water objects.

The water objects were classified with different methods and evaluated accuracy of those methods. The conclusion was that NIR2 band is the most efficient in determining water branches in Yangiobod and Beshbulak villages of Sirdarya region then other indexes and layers. Investigations demonstrated that, NIR2 layer showed the highest accuracy. According to this formula we could extract 19 water objects from desert area and 26 water objects from the river area (Fig. 2).

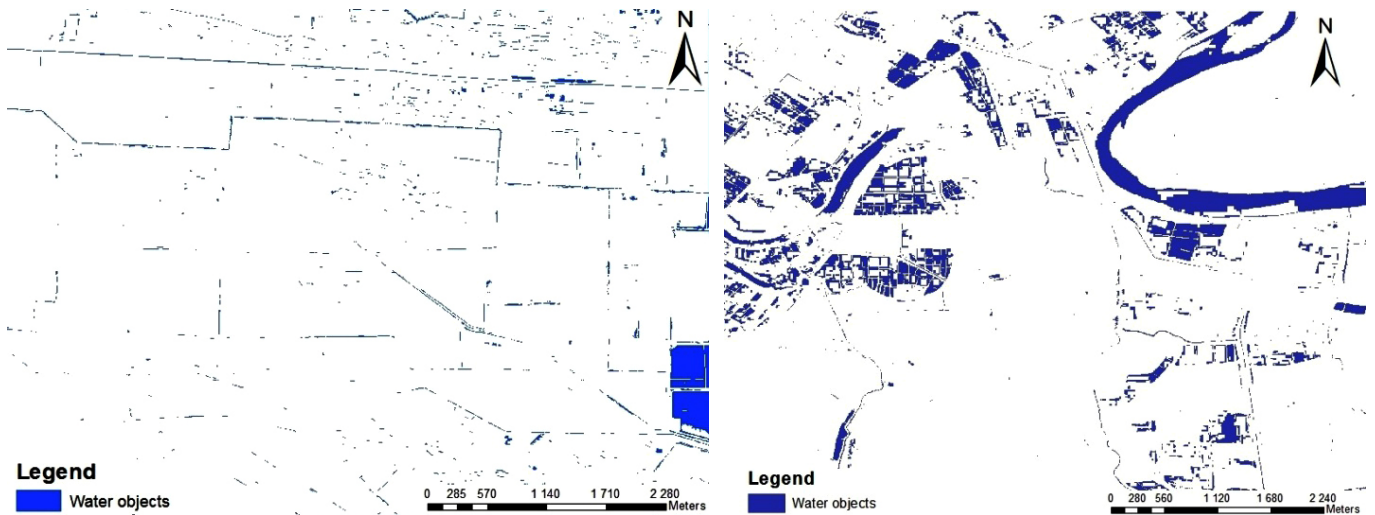

Figure 2. NIR2 Water extraction analysis with using NIR2 band result for Yangiobod And Beshbulak villages

By the results of this analysis we can recommend the optimal index for calculating water objects. The established new and rich map for water sets and resources is of benefit for the region. We faced some difficulties in detect-

ing small water objects in Beshbulak village. It was impossible to separate rice fields from water objects as they were filled with water. Moreover, groundwater has also mixed with water objects as they come to the surface. This issue

could be observed in Dubovyk et al., [2]’s work. They classified water objects with the OBIA method and classified above mentioned waters as agricultural lands. In conclusion, they marked those areas as flood areas.

4. Conclusions

For analysing irrigation sets and controlling their exploitation period, reconstructing and calculating its water share, irrigation sets extraction methods were created with the help of WV2 data. It is a valuable information base for the region’s agriculture. This information has very important consequences for the region.

Analysis brought the following general results:

- OBIA is the most reliable and advanced method for analyzing RS images, it gives the possibility of analyzing water objects conditions;
- The NIR2 band gives the best results in identifying water objects in Syr-Darya Province;

Our research work concerns a scientific analysis of Syr-Darya region’s water resources and RS, preventing the following problems and introducing the following novelties.

Acknowledgements

The author is grateful to Erasmus Mundus Eurasian-CEA scholarship, Lille1 University Science and technology, Doctoral department SESAM and Laboratory TVES, head and personnel of departments of UFR “Geography and urban planning” and “Department of International affairs”: Prof. Philippe Deboudt, Prof. Francois-Olivier Seys, Christine Vandebosch, Mojca Maher Pirc, Veronique Level, Antoine Sugita, Klavdija, Emeline Marchesse and others, “Tashkent Institute of Irrigation and Melioration” in Uzbekistan head and personnel of departments of Hydromelioration: Prof. Mukhamadkhon Khamidov, Dr. Bakhodir Mirzaev, Dr. Toxir Sultanov and others, head of UzGidroMet centre Dr. Bakhriddin Nishanov and others for providing financial and material assistance to carry out this research work, who supported with materials and finance during the writing of this article. The author is especially grateful to his supervisors Prof. Olivier Blainpain and Dr. Eric Masson.

References:

1. Chen G., Hay G.J., Carvalho L.M.T. & Wulder M.A. Object-Based Change Detection. *International Journal of Remote Sensing*, 33 (14).– 2012.– P. 4434–4457.
2. Dubovyk O., Menz G., Conrad C., Thonfeld F. & Khamzina A. Object-Based Identification of Vegetation Cover Decline in Irrigated Agro-Ecosystems in Uzbekistan. *Quaternary International, Hydrological and Ecological Responses to Climatic Change and to Land-use/land-cover changes in Central Asia*, 311.– 2013.– P. 163–174.
3. Jawak S.D., & Luis A.J. A Spectral Index Ratio-Based Antarctic Land-Cover Mapping Using Hyperspatial 8-Band WorldView-2 Imagery. *Polar Science*, 7 (1).– 2013.– P. 18–38.
4. Jawak S.D., & Luis A.J. A Rapid Extraction of Water Body Features from Antarctic Coastal Oasis Using Very High-Resolution Satellite Remote Sensing Data. *Aquatic Procedia*, 4.– 2015.– P. 125–132.
5. Mc. Feeters S.K. The Use of the Normalized Difference Water Index (NDWI) in the Delineation of Open Water Features. *International Journal of Remote Sensing*, 17 (7).– 1996.– P. 1425–1432.
6. Navulur K., Pacifici F. & Baugh B. Trends in Optical Commercial Remote Sensing Industry [Industrial Profiles]. *Geoscience and Remote Sensing Magazine*, 1 (4).– 2013.– P. 57–64.
7. Wolf A. F. (2012). Using Worldview-2 Vis-NIR Multispectral Imagery to Support Land Mapping and Feature Extraction Using Normalized Difference Index Ratios. In *SPIE Defense, Security, and Sensing*. DOI: 10.1117/12.917717.
8. Wolf A. T., Natharius J.A., Danielson J.J., Ward B.S. & Pender J.K. International River Basins of the World. *International Journal of Water Resources Development*, 15 (4).– 1999.– P. 387–427.

*Babakhanova Madina Avazovna,
scientific employee,
Tashkent state technical university,
E-mail: polycomft2005@rambler.ru*

*Negmatova Kamila Soyibjonovna,
doctor, of the technical sciences,
Tashkent state technical university,
E-mail: polycomft2005@rambler.ru*

MODIFIED ANTICORROSIVE PAINT COATINGS

Abstract: That at process of formation of a composite covering of optimum temperatures hardening the developed composition should consider 120–140° C.

Keywords: anticorrosive materials, kaolin, lignin, industrial waste.

Introduction

Many anticorrosive materials are manufactured with application not one but several polymers, their mixes. The properties of such materials depend on structure of a mix, properties of their components and their compatibility, modes of mixture and subsequent technological processes.

The specificity of polymeric coverings formed from coatings systems, consists that the process of hardening them is connected to course polymers on a substrate finished by formation of above molecular structures, forming a spatial grid [1].

Materials and methods

In this connection we modify epoxide resin with cubic rest pentozan of connection (COPC). Composition, developed by us, on a basis rest of pentozan containing combination with epoxide pitch of the mark ED-20, filled with various mechanical activated fillers (kaolin, lignin, industrial waste, confirmed with the help of reagent hardening – polyetelinpolyamin.

The formation of defects at hardening coverings usually contacts to destruction of bubbles, hit of a dust-increased humidity of air, non-uniform distribution hardener in oligo measure system and non-uniform hardening of different sites of a surface by a regrouping of structural elements under action of internal voltage.

For estimation of influence of temperature of hardening on time of drying and the physical – mechanical properties of coverings of research are carried out at temperatures from 40 up to 200° C. The process of drying of a composition was carried up to a degree 3, characterized by absence of a trace and sticking a paper after removal of

loading in 0,2 H, according to a standard technique [2]. The results of tests are submitted in the table 1.

Results and discussions

As it is shown thermal hardening at temperatures up to 80° C passes during long time from 3 till 1,5 hours, thus the generated coverings have not enough high physical –mechanical parameters. The realization of process drying at temperatures 100–180° C allows at much small expenses of time to receive completely formed covering, justified by high parameters of hardness describing a degree hardening. The further increase of temperature results to dark a film of a covering.

In domestic and foreign practice for protection of machines, equipment both equipment from deterioration's and corrosion the wide application is found by coverings on the basis of greasiness of the developed polymeric materials providing their long safety in various conditions of operation, and also high physical-chemical, mechanical properties.

It is known, that during operation of the automobile vanish dying covering is exposed to destroying influence of the various factors – water, oxygen, solar radiation, change of temperatures, sulphurous and other gases contained in air of industrial areas, dust, salts etc.

Use of fillers (kaolin, lignin, waste of gold extraction industry) allows considerably to improve a complex of physical-mechanical and operational properties.

For realization of samples on an aggressive resistance as aggressive surroundings used chemical reagent, according to GOST 4204–77. In our work is basically used 30% concentration of H₂SO₄, density 1,84.

The test of the not filled and filled composite on chemical resistance was carried out according to GOST 9.403–80 by the method of complete immersing of samples in a solution of a sulfuric acid (table).

Table 1. – Influence of temperature hardening on time of drying of a composition, durability at impact, adhesive and hardness of coverings on a basis CRPC+ED-20

Temperature, °C	Time hardening up to a degree 3.4	Hardness of coverings, relative unit.	Adhesive in numbers	Durability at impact, kgs.sm
50	3	0.35	2	35
80	2	0.37	2	35
100	1.5	0.40	2	35
120	0.75	0.45	1	40
150	0.5	0.47	1	50
200	0.25	0.45	1	40

In the table the data on preservation of protective properties of coverings with various fillers and without them are submitted.

From the table it is visible, that the specified system binding + kaolin, binding + lignin and binding + waste keeps protective properties without change during 120–150 day, at the same time on the not filled samples the attributes of destruction of coverings are marked already ambassador 60–70 day of tests.

Summary

Thus on the basis is higher stated it is possible to conclude, that at process of formation of a composite covering of optimum temperatures hardening the developed composition should consider 120–140 °C.

That a filler shows a certain positive effect and increases a way of passage of aggressive surrounding into the depth of a matrix. The developed composite polymeric material can be successfully applied for a covering of units of machines working in aggressive conditions.

Table 2. – Dependence of protective properties of systems chemical resistant coverings with chemical resistant coverings from time of its presence in 30% - H₂SO₄

The name of a material	Duration, day	Protective properties, %
The not filled composite	100	60
	200	40
	300	30
	400	25
Composites filled with kaolin	100	75
	200	65
	300	60
	400	60
Composite filled with lignin	100	80
	200	75
	300	70
	400	68
Composite, filled by a waste	100	90
	200	85
	300	80
	400	80

References:

1. Karyakina M. I. Test of varnish dying of materials and coverings. – M. Goschimizdat, – 1989. – 280 p.
2. Ravitch B. M. and others. Complex use of raw material and waist. – M. Chemistry, – 1988. – 288 p.

Komilov Ne'matilla Muhammadjonovich,
 researcher, Scientific research institute
 of mechanization and agriculture electrification
 Republic of Uzbekistan
 E-mail: knm_1977@umail.uz

THEORETICAL BASES OF FORMING AN EARTH BED BY MEANS OF SPHERICAL DISKS

Abstract: In the article about the theoretical foundations of the shape of a spherical disk can be realized by changing the angle of rotation relative to the direction of movement of the disks to form the required level of operating conditions.

Keywords: diameter of disk, installation angle of disk with regard to motion direction, ascending angle of soil pieces through the running surfaces of disk, depth of sinking disks into the soil, height of earth bed being formed, spreading away distance of soil pieces coming out from the disk in the longitudinal direction.

The results of conducted analysis on the literature and comparative test implementations [1] showed that it is reasonable to apply the spherical disks in by consuming a less energy (power) and by this way to reach the required level of forming a earth bed.

In conditions of our country, making spherical disks have been studied by several researchers [2] researchers base on the researches implemented by them and each earth bed shall be formed by two disks installed at the opposite position each one another of (Scheme 1).

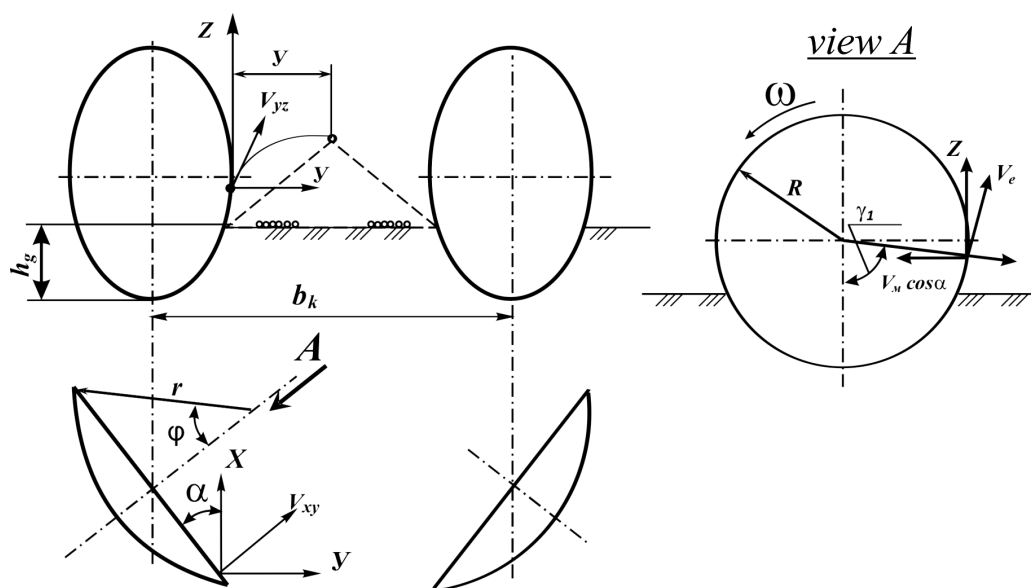

Scheme 1. Of forming the earth beds by spherical discs

In this case the following terms should be executed

$$h_g = \frac{H_n \sqrt{k_c}}{1 + \sqrt{k_c}}. \quad (1)$$

and

$$0,5D \sin \gamma_1 \sin \alpha < Y < b_k - D \sin \gamma_1 \sin \alpha, \quad (2)$$

In this case h_g – depth of sinking disks into the soil;
 H_n – height of earth bed being formed;
 k_c – coefficient of soil tillage;
 D – diameter of disk;

γ_1 – ascending angle of soil pieces through the running surfaces of disk;

α – installation angle of disk with regard to motion direction;

Y – spreading away distance of soil pieces coming out from the disk in the longitudinal direction.

In case if the 1st term is executed in order to form earth bed it will be enough for the required level level a height of soil excavated by the disks.

In case if the 2nd term is executed the soil pieces will drop onto the middle part of earth bed that means an earth bed is formed at the account of spreading away under the dropping down angle naturally. It outcomes in forming stable and big heighted earth bed.

By using the following formula we may determine the spreading away distance of the soil pieces coming out from the disk longitudinally [3].

$$Y = \frac{1}{g} \left[V_r^T (\sin \phi_0 \cos \alpha + \cos \phi_0 \sin \alpha \cos \gamma_1) - 0,5V_a \sin 2\alpha \sin \gamma_1 \right] \times \quad (3)$$

$$\times \left[V_a \cos \alpha \cos \gamma_1 + V_r^T \cos \phi \sin \gamma_1 + \left\{ \left[V_a \cos \alpha \cos \gamma_1 + V_r^T \cos \phi_0 \sin \gamma_1 \right]^2 + 2g \left[R(1 - \cos \gamma_1) - h_g \right] \right\}^{\frac{1}{2}} \right]$$

in this formula ϕ_0 – soil pieces outgoing angle out from the disk, degree;

V_r^T – relative velocity of soil pieces coming out from the disk throughout disk working surface, m/s;

V_a – assembly speed, m/s.

After analysis of the formulas (1), (2) and (3) it is seen, that in effort to reach forming an earth bed with the required level disks should move under the soil at a certain depth and at the same time relatively installation angle and motion velocity can be changed relatively due to its diameter, motion direction.

Regarding the formula (1) in order to form the earth beds in accordance with the agricultural requirements (24 ± 3 cm) average sinking depth of the disks into the soil should be 11,92–14,63 cm.

From the literature materials it is known, that the disk diameter is related with its sinking depth into the soil and by using the following formula it may be determined [3–4]

$$D = k_n \frac{H_n \sqrt{k_c}}{1 + \sqrt{k_c}}, \quad (4)$$

In this case k_n – is coefficient equal to 2.5 – 4.0 [5] for the earth bed forming assembly;

Lets put k_n with its values as it is identified and h_g with its values as above specified (4), and so determine the necessity of the disk diameter to be at 480–580 mm.

So if we consider these results, in effort to form earth beds for the required level for provided (set) labor conditions and speed range it should be implemented by way of changing the installation angle relative to motion direction of the disks.

References:

1. Khojiyev A., Komilov N. Choosing the type of earth bed forming operating element // “Independent training of competitive personnel: cooperation of world education system with higher education institutions” Materials collection of Republican scientific-practical conference. 20–21st of May – 2010. – Namangan, – 2010. – P. 76–78.
2. Khudoyorov A., Igamberdiyev A. Introducing the process of tilling earth beds forming by means of minimum tilling earth beds forming combined unit into practice // Effective using of new foreign machines and technologies under the soil climatic conditions of Ferghana valley. – Andijan. – 2009. – P. 159–162.
3. Hamidov A. Design of agricultural machines. – Tashkent: Teacher, – 1991. – 246 p.
4. Shoumarova M., Abdullayev T. Agricultural machines. – Tashkent: Teacher, – 2002. – 424 p.
5. Postnikov N. M. and others. Potatoes sowing machines. – M.: “Machinery” – 1981. – P. 93–105.

*Mamaraufov Odil Abdikhamitovich,
scientific researcher, the Department of Software of IT,
Tashkent University of IT,
E-mail: odil.mamaraufov@gmail.com*

DETECTION AND DETERMINATION COORDINATES OF MOVING OBJECTS FROM A VIDEO

Abstract: This paper is devoted to the creation of an efficient algorithm for determining the motion detection and isolation of an object based on background subtraction using dynamic threshold and morphology in the process. Background subtraction algorithm may also be used to detect multiple objects. Video images of human to identify methods to distinguish moving objects, the image of the reference image based on moving images through the search. Main components of the paper based on the analyses of stage of few hundred dynamic objects image sector, the separation and identification algorithms and software development. Algorithms developed can also be used for other applications (real-time classification of objects, etc.).

Keywords: Video surveillance, motion detection, background subtraction, background.

Introduction. This time the relevant tasks are the collection, analysis and processing of information on road safety, safety control, traffic on city streets and highways, road accidents and their study. Also relevant is the problem of determining the speed of traffic on motorways, registration of motor vehicles at intersections, posts and vehicle registration, car traffic and frequent road accidents. So important is the creation and implementation of video surveillance systems installed in roads and intersections. For the video surveillance system is an actual resolution of contradictions between the quality of the generated image and hardware of existing channels of communication and data storage. In spite of the high capacity, the modern hard disks are not sufficient for storing large amounts of information for a long time, as it should be according to the specifications. Traditionally this contradiction is resolved by video compression with a noticeable decrease in their quality and loss of information. To improve the efficiency of video surveillance systems need to develop methods for video data compression without loss of information about the object of interest for the long term storage and transfer in real time, high-quality images via communication channels with limited bandwidth [3]. Video moving object leads to the appearance of two phases-phase of adaptation to the current camera angle shooting and maintenance of objects of interest. The fixed camera shot scene with little

changing background (relative sequence) with moving objects is of great practical use in observation systems (maintenance of vehicles, people), security systems, etc.

Existing Work. Currently, there are many methods of detecting motion, or in another way, methods of subtracting the background. In addition to methods of subtracting the background, methods for preprocessing and post-processing of data were implemented: the Gaussian filter, binarization, and the median filter. In the literature, there is a comparative analysis of video motion detection methods based on execution time, consumed resources and calculation of metrics: precision, recall, F-measure. None of the background modeling algorithms can cope with all possible problems. A good background subtraction algorithm should be resistant to changes in lighting and avoidance of non-stationary background objects such as swinging leaves, grass, rain, snow and shadows from moving objects should be avoided. And the background model must respond quickly to changes: such as starting and stopping vehicles or any other starting point.

In the practice of disclosure and investigation of crimes, materials obtained by television monitoring systems that allow recording certain elements of the mechanism of committing a crime and criminals by means of video recording are quite often used. During the analysis of video images, forensic information can be obtained that helps to establish the spatial characteristics of the

imprinted objects, their group identity and to carry out identification [4].

Existing gaitoscopic techniques of forensic identification of a person on the grounds of appearance [5], imprinted on a video images are based on portrait identification using static images [6]. In some cases, these methods are powerless, for example, when the person of the offender is not visible, fixed in an unsuccessful foreshortening, hidden by a mask or dressed up.

The materials of the video recording contain a considerable amount of information on the volume and variety related to the functional elements of the appearance of a person (gait, facial expressions, articulation, gestures, etc.) [4]. These elements can be fixed and perceived for research only in dynamics as static illustrations of a person's appearance do not convey these properties. Dynamic properties of changes in the appearance of a person are very informative and are characterized by individuality, dynamic stability, selective variability, which allows them to be used to solve forensic tasks.

Recently, work is underway in our country and abroad to create new biometric technologies and security systems that measure various parameters and characteristics of humans [5]. These include the individual anatomical characteristics of a person, except for the face and fingerprints (the eye fundus, the iris of the eye, the shape of the palm of the hand, etc.), and its physiological and behavioral properties (voice, signature, gait, etc.). Such systems are created to restrict access to information, prevent intruders from entering protected areas and premises, but they can also be used in forensic science. The modern capabilities of biometric technologies already provide the necessary requirements for reliability of identification, easy for use and low cost of equipment.

Methods of linear filtering images. The filtering methods when evaluating the real signal at some point in the frame to take into account a lot of (neighborhood) of neighboring pixels, using a certain similarity of the signal at these points. The concept of neighborhood is fairly conventional. The neighborhood can be formed only on frame closest neighbors, but may be a neighborhood containing enough and strong enough distant points of the frame. In this case, the degree of influence (weight) of the far and near points on the decisions taken by the filter at a given point of the frame, will be completely different.

Thus, the filtering based on the ideology of the rational use of the data as a working point, and from its vicinity.

For solving the problems of filtration using probabilistic models and image noise and statistical optimality criteria apply. This is due to the random nature of the interference and the desire to obtain the minimum difference in average processing result from the ideal signal. The variety of methods and filtering algorithms associated with a wide variety of mathematical models and noise signals, as well as various optimality criteria.

There is a whole class of methods attenuation noisy images, as well as able to perform other operations (blur, border selection) based on the original image of the linear filtering. Linear filtering involves the use of a pixel raster spatially invariant transformation that would emphasize the necessary elements of the image and to avoid the influence of other, less important.

The filter is based on linear convolution operation, which is written for the discrete case as in formula (1)

$$q[m,n] = f[m,n]g[m,n] \quad (1)$$

where q – resulting raster obtained after convolution, m, n – coordinates x and y , which is performed in the convolution, f, g – baseline rasters. As raster f taken convolution kernel, which is a matrix of small dimension (usually no more than 5×5 elements), g – the original image, which should be filtered.

In more detail the operation of convolution is painted in the formula (2)

$$q[m,n] = \sum_{j=-u/2}^{u/2} \sum_{k=-v/2}^{v/2} f[j,k] \cdot g[m-j,n-k], \quad (2)$$

where j, k – meters horizontally and vertically in the calculation of convolution, u, v – linear convolution kernel sizes (width, height), the remaining symbols correspond to those of the formula (1).

One of the special case of application of the linear filter to the video images is the implementation for the purpose of smoothing convolution. Anti-aliasing smoothes jumps brightness of the image and allows you to remove unwanted noise.

Most often used for smoothing kernel convolution 3×3 , since in most cases they can achieve the desired effect, the price is relatively high, but still acceptable effort. Kernels fold dimension of $5 \times 5, 7 \times 7$, etc. They used very rarely because of too much labor. For example, the use of 5×5 convolution with the kernel, in comparison with the case of giving a $3 \times 3 (5/3) * (5/3) = 25/9 \approx 2.78$

times more processing operations on a single image pixel. Odds before the cores are selected so that the conversion did not cause the displacement of the original brightness of the image.

As you can see, the core of the convolution of even minimal dimension (3×3) will significantly distort the image, because the color of any specific pixel will affect its neighbors. Moreover, the larger dimension of the convolution kernel, the greater will be the impact of this. In addition, the smaller the ratio of the central matrix for the convolution kernel (the central coefficient corresponds to the pixel being processed), the greater the distortion. Distortion during this processing method is expressed as the lubrication of small parts, blurring edges, smoothing contrast transitions.

Second we are interested in how to use linear filtering to the processing of video images – the convolution with the kernel to emphasize the edges (aka Edge Detect). Such convolution kernel allows highlight the contours of objects and to suppress other elements of the image. Among the convolution kernels for this purpose, there are several basic is: Sobel Edge Detector, Gauss Edge Detector, Prewitt Edge Detector, Second-Derivatives filter. Matrix for them as follows (4).

Median filter, unlike the smoothing filter, realizes a non-linear noise reduction process. As for the impulse noise, then, for example, a median filter with a window of 3×3 is completely suppresses single uniform background emissions as well as a group of two, three or four pulsed emission. In general, for suppressing impulse noise band the window size should be at least twice the size of the group of interference. Along with the important advantage of the median filter is the fact that it is significantly less blurs the contours of objects in the image, this approach has a major drawback associated with the fact that the calculation of the median requires additional computational cost. After all, despite the fact that the complexity of calculating the median of the array element in the middle – there is order $O(n)$, is necessary to resort to additional tricks to practice really achieve linear complexity. But worst case reaches the difficulty still $O(n^2)$, especially if the number of elements in the array is small (in this case, there are only 9).

Brightness and Contrast Adjustments. We looked at some ways to remove noise from the original image. However, the stage of pre-processing of video on it usually does

not end there. Removing noise to minimize the number of false positives in the difference motion detector from interfering with reception and transmission of images, but the images containing the same scene, then can still vary significantly. The reason for this difference is the change in the level of illumination for registration of different frames. Changing the lighting level it may be caused by turning on or off the artificial lighting or weather conditions change, if the shooting is done outdoors. Usually at this point element wise difference between two adjacent frames reach very high values, which leads to false alarm detector, which detects the movement of the whole space lighting changes. To avoid such false alarms, at the stage of pre-treatment is necessary to resort to an adjustment of the brightness level of video [4, 8].

In calculating the brightness of the pixels of the current frame will be based on the pixels of the previous frame:

$$I_2(x, y) = A(x, y) \cdot I_1(x, y) + B(x, y), \quad (3)$$

where $I_1(x, y)$ – the brightness value of the pixel of the previous frame, $I_2(x, y)$ – the brightness value of the pixel of the current frame, $a(x, y)$, $b(x, y)$ – linear transform coefficients.

In general, a and b are the sets of data containing different values for each pixel. In practice, this requirement is usually simpler and replaced by an algorithm window area processing several tens of pixels within which the calculated values of the coefficients a and b , followed by an adjustment of these pixel values falling within a window in the current frame. Then, the window is moved to a new location, thus avoiding the entire frame.

It only remains to calculate the coefficients a and b . In [8] proposed two methods, one of which is based on the multiplication of luminance values of pixels of the current frame by a factor that converts the current frame to the same average luminance as in the previous frame:

$$a(x, y) = \bar{I}_2 / \bar{I}_1 \quad (4)$$

where \bar{I}_1 and \bar{I}_2 – the average brightness values in the previous and current frames, respectively. At this shear rate is not used:

$$b(x, y) = 0. \quad (5)$$

The second way to agree on neighboring frames on the average brightness value and variance:

$$\begin{aligned} a(x, y) &= \sigma_2 / \sigma_1, \\ b(x, y) &= \bar{I}_2 - (\bar{I}_1 \sigma_2 / \sigma_1) \end{aligned} \quad (6)$$

where σ_1 and σ_2 – mean square deviation of brightness in the previous and current frames, respectively, the remaining symbols are the same as in (4) and (5). Note that the processing of a sliding window averages and standard deviations of the value calculated by the inner pixels of the window.

Histogram bias is eliminated by the linear contrast, the idea of which is to convert the intensity of each pixel of the image with respect to the maximum and minimum values in the histogram for the current frame:

$$u'[m, n] = (u[m, n] - c) \cdot (b - c) / (d - c) + a, \quad (7)$$

where $u[m, n]$ – pixel of the original image with the coordinates (m, n) , $u'[m, n]$ – pixel of the output image with coordinates (m, n) , a – the lowest possible intensity value, b – the maximum possible value intensity, c – the minimum intensity value among pixels of the frame, d – the highest possible intensity value among the pixels of the frame.

Thus, all the intensity values that fall between the percentiles will be scaled and the other extreme values of a gain or b :

$$u'[m, n] = \begin{cases} a, & \text{if } u[m, n] \leq p_{low\%} \\ u^p[m, n], & \text{if } p_{low\%} < u[m, n] < p_{high\%} \\ b, & \text{if } u[m, n] \geq p_{high\%} \end{cases} \quad (8)$$

where $p_{low\%}$ – lower percentile (in this case, 1%), $p_{high\%}$ – the upper percentile (in this case 99%), the remaining symbols are similar to the notation for the formula (7)

$$u^p[m, n] = (u[m, n] - p_{low\%}) \cdot \frac{b - a}{p_{high\%} - p_{low\%}} + a.$$

Nor cut-off top and bottom 1% of the values, can use 3% and 5% thresholds and etc.

In this way, adjusting contrast noisiness on the tails of the distribution will not have a significant effect on the maximum and minimum for which will be scaled intensities, so this method is more resistant to the presence of noise.

In addition to increasing the contrast, at the stage of preparation of video image processing to the difference motion detector, it is important to bring these images to the same species. By this we mean a transformation of the original image, after which the color intensity histogram becomes uniform for all intensity values, which means that all values are equally probable [6].

This effect is achieved by replacing the distribution function of the pixel intensity of the color value with

equal argument of the largest intensity by a factor of at available to the number of levels of intensity:

$$k = u[m, n], \\ u'[m, n] = (b - a) \cdot n_k / N^2, \quad (9)$$

where, $u[m, n]$ – pixel of the original image with the coordinates (m, n) , $u'[m, n]$ – pixel of the output image with coordinates (m, n) , a – the lowest possible intensity value, b – the maximum possible value intensity, n_k – number of pixels in the original image with an intensity level equal to or less than k , N – total number of pixels in the image.

After treatment with this method, all frames of the video stream will be similar in the level of illumination (and the distribution of the number of pixels from the values of the intensity will be close to a uniform) that will prevent false alarms difference motion detection.

The method of the frame difference. Calculation of frame difference is a very common method of detecting the primary motion, after performing which, generally speaking, we can say whether there is a flow of personnel movement. Until recently, many motion detectors functioned exactly according to this principle [4]. However, this approach gives a fairly rough estimate, leading to the inevitable presence of the false reaction detector noise recording equipment, changing lighting conditions, a slight swing of the camera and so on. Thus, the videos need to be pre-treated prior to the calculation of the difference between them.

Algorithm for computing frame difference of two frames in the case of processing a color video in RGB format is as follows:

1) The input to the algorithm receives two video frames, which are two-byte sequence in RGB format.

2) calculates pixel inter-frame differences as follows:

$$R_d^i = |R_1^i - R_2^i| \\ G_d^i = |G_1^i - G_2^i| \\ B_d^i = |B_1^i - B_2^i| \quad (10)$$

where R_d^i, G_d^i, B_d^i – values of red, green and blue color components of the i -th pixel of the resulting raster, $R_1^i, G_1^i, B_1^i, R_2^i, G_2^i, B_2^i$ – the values of red, green and blue color components of the i -th pixel in the first and second frame.

3) For each pixel the average value between the values of three color components:

$$z^i = (R_d^i + G_d^i + B_d^i) / 3 \quad (11)$$

4) The average value is compared with a predetermined threshold. As a result, comparison of the binary mask is formed:

$$m^i = \begin{cases} 0, z^i < T \\ 1, z^i > T \end{cases} \quad (12)$$

where m^i – i – th value of the mask element, T – comparing the threshold, sometimes referred to as a threshold or a sensitivity.

Thus, the output of the algorithm is formed by a binary mask, one element of which correspond to the three color components of the corresponding source pixel two frames. The units are arranged in the mask in areas where possibly present motion at this stage, but can be separate elements false alarms mask erroneously set to 1.

The two consecutive frames from the stream, but may use frames with a long interval, for example, equal to 1.3 can be used as a frame of the two input frames. The greater this interval, the higher the sensitivity of the detector to the inactive objects, experiencing only a very small shift in one frame and can be clipped, being ascribed to the noise component of the image.

The advantage of this method is its simplicity and undemanding to computing resources. The method is widely used earlier on the grounds that there was insufficient processing power available to developers. However, it is now widely used, especially in multichannel security systems where it is necessary to process the signal from multiple cameras to one computer. After all, the complexity of the algorithm is of order $O(n)$ and is carried out in just one pass, which is very important for a large raster dimension, such as 640×480 pixels, 768×576 pixels, with which modern video cameras often work.

Results. Besides the fact that the implemented algorithm allows to process data in real time and to provide them moving objects, it has one very important feature. It lies in the fact that the program is written on the basis of this algorithm, it is a full-transforming the DirectShow filter. This means that, firstly, it is compatible with other DirectShow-filter and can be included in a filter graph, and secondly, it can easily be used by any application in which to detect movement in the video data. To this end, the program developers need only to know the unique identifier of the class and interfaces used in this filter detects motion. Then, after the resulting interface program can communicate with the connected to the column filter setting adjustable parameters and thus realizing its setting.

The scheme used algorithm detail to the level of processing procedures, and input / output parameters is shown in (Figure 1).

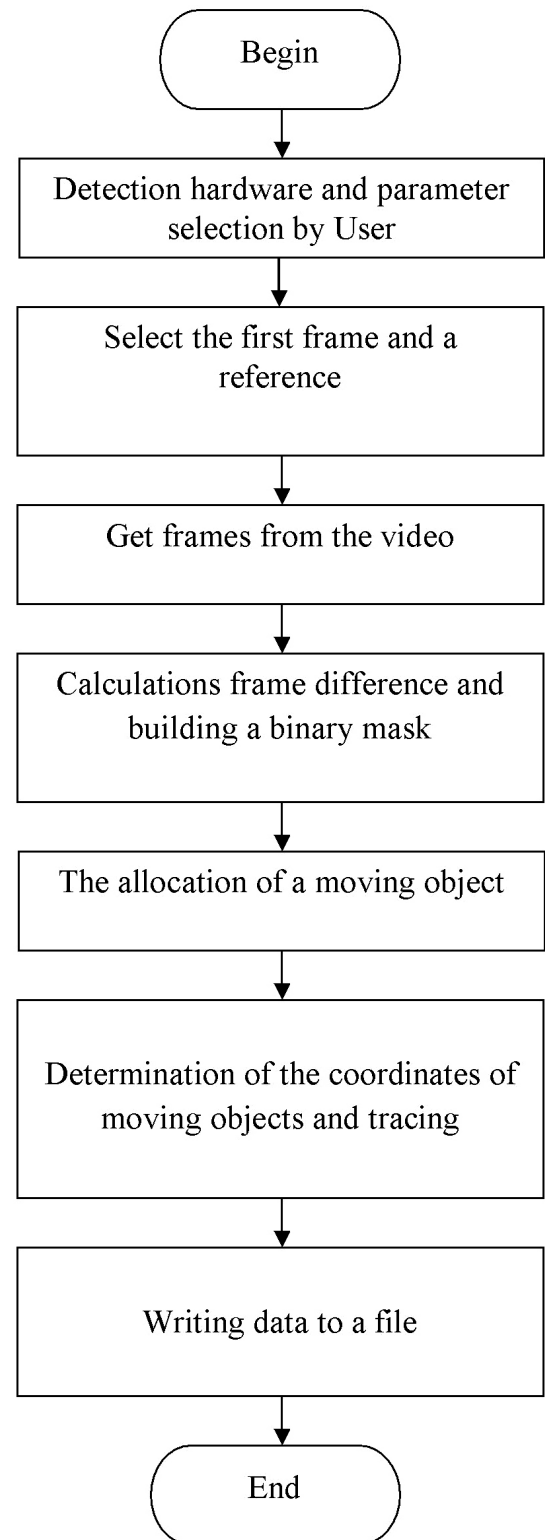

Figure 1. Stages of the modules

The algorithm consists of the following steps:

Step 1. Saved $K-2$ ($K-2$ frame is)

Step 2. Saved $K-1$ ($K-1$ block)

Step 3. Saved K – (current frame)

Step 4. Ref. Frame $K-1$ (base frame)

Step 5. Ref. Frame K (updated base frame)

Step 6. Mask_ B (mask on the difference between the current and the base frame)

Step 7. Rectangles (an array of rectangles flanking group of connected minzon)

Step 8. Objects $K-1$ (an array of objects from the previous frame)

Step 9. Objects K (array of objects after the current frame processing)

The following notation is used for operations:

- Interpolate – procedure of frame filtering
- Minus – the difference between the two
- Morphology – performs filtering operations of mathematical morphology
- SearchRectangles – search boxes on the difference mask
- ProcessObjects – the search for new objects and tracing old
- PostProcessObjects – removal of unnecessary objects
- SetRectAreaValue (rectangles, map) – marks the pixels belonging rectangles rectangular area on the specified map pixel map
- UpdateRefFrame – updates the pixels of the base frame.

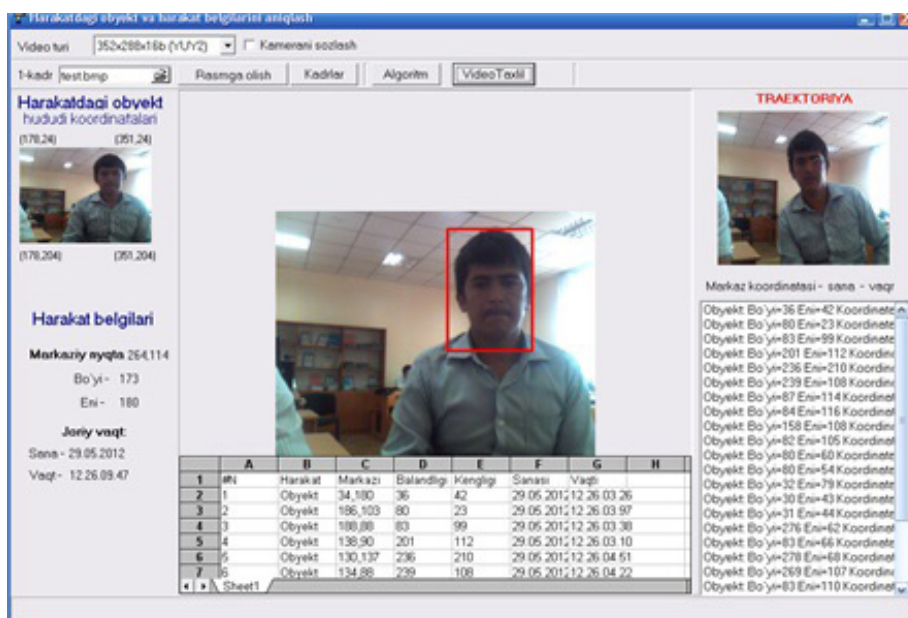

Figure 2. Software for Detection and determination of the coordinates of moving objects on the video

When pressing the button shows Algorithm algorithm preprocessing and detection of a moving object (Figure 4).

The software is developed in language Delphi 7. The software is installed on a computer running a surveillance camera.

Software removes the images in the format *.BMP of video over a range of time and sequences of images supplied to the algorithm.

The program contains both the original versions of functions that implement these operations, and optimized the use of which is possible if you want users to speed up the work of the detector and if it has a processor not lower than Intel Pentium IV.

Discussion. During the reviewed methods of image processing and detection of moving objects in a stream of video frames. For a number of methods have been implemented algorithms allowed to apply these techniques in the detector of moving objects.

Based on implemented algorithms was developed detection of moving objects. Designed detector is characterized by high quality of detection, resistance to noise recording equipment, peculiarities of weather conditions, the ability to work in daylight and artificial light, high-speed processing provides 1 channel video with a resolution of 640×480 pixels at a speed of 8–10 frames per second.

	A	B	C	D	E	F	G	H
1	#N	Harakat	Markazi	Balandligi	Kengligi	Sanasi	Vaqt	Sinfi
2	1	Obyekt	590,317	3	5	02.06.2016	15.29.05.1	3-sinf
3	2	Obyekt	595,312	1	2	02.06.2016	15.29.06.4	3-sinf
4	3	Obyekt	413,244	298	274	02.06.2016	15.29.06.9	To'silgan
5	4	Obyekt	438,271	364	294	02.06.2016	15.29.06.1	To'silgan
6	5	Obyekt	460,188	183	259	02.06.2016	15.29.07.3	To'silgan
7	6	Obyekt	443,272	364	281	02.06.2016	15.29.07.5	To'silgan
8	7	Obyekt	395,244	295	281	02.06.2016	15.29.07.7	To'silgan
9	8	Obyekt	354,265	330	274	02.06.2016	15.29.07.9	To'silgan
10	9	Obyekt	405,293	166	63	02.06.2016	15.29.07.1	3-sinf
11	10	Obyekt	311,291	354	263	02.06.2016	15.29.08.2	To'silgan
12	11	Obyekt	335,274	364	237	02.06.2016	15.29.08.6	To'silgan
13	12	Obyekt	389,276	389	268	02.06.2016	15.29.08.9	To'silgan
14	13	Obyekt	436,236	340	278	02.06.2016	15.29.08.3	To'silgan
15	14	Obyekt	429,265	396	270	02.06.2016	15.29.09.6	To'silgan
16	15	Obyekt	392,268	374	238	02.06.2016	15.29.09.8	To'silgan
17	16	Obyekt	345,287	366	205	02.06.2016	15.29.09.4	To'silgan
18	17	Obyekt	355,299	360	210	02.06.2016	15.29.09.2	To'silgan
19	18	Obyekt	397,298	361	316	02.06.2016	15.29.09.4	To'silgan
20	19	Obyekt	337,252	265	188	02.06.2016	15.29.10.6	To'silgan
21	20	Obyekt	343,251	263	175	02.06.2016	15.29.10.7	To'silgan
22	21	Obyekt	280,142	36	43	02.06.2016	15.29.10.1	3-sinf
23	22	Obyekt	399,160	54	65	02.06.2016	15.29.11.8	3-sinf
24	23	Obyekt	343,340	278	173	02.06.2016	15.29.11.5	To'silgan
25	24	Obyekt	424,259	113	339	02.06.2016	15.29.12.4	To'silgan

Figure 3. Formation of the report as a spreadsheet

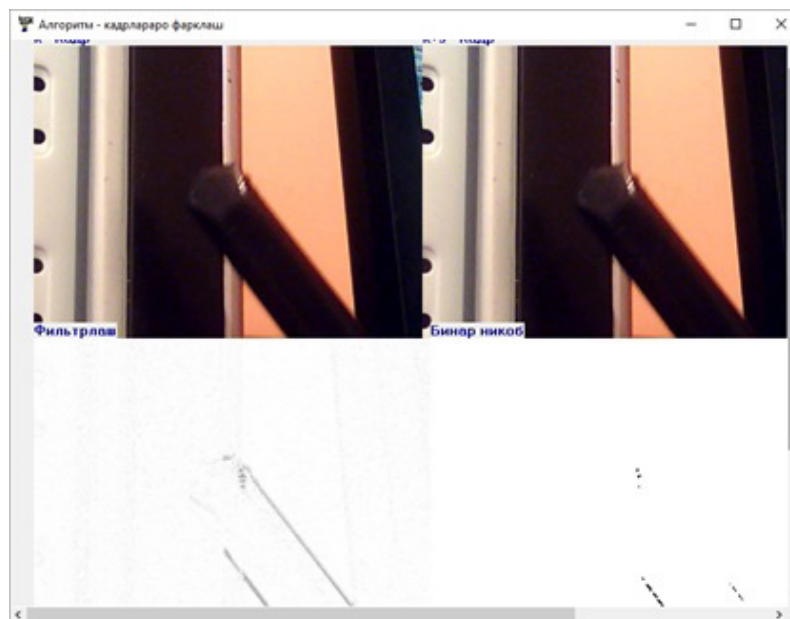

Figure 4. Results of frame difference and median filtering

When implementing modern powerful detector technology have been used, such as the COM and DirectShow, optimization was performed bottleneck algorithm using MMX instruction sets for SSE and acceleration of its operation.

At all stages of the development work carried out thorough testing of individual parts of the algorithm, as well as the entire detector as a whole.

Conclusion. Detecting and tracking moving objects are important topics in computer vision research. Classical detecting and tracking methods for steady cameras are not suitable for use with moving cameras because the assumptions for these two applications are different. In this work developed algorithms that can detect and track moving objects with a non-fixed position camera. The initial step of this research is to develop a new method for estimating camera motion parameters.

References:

1. Anam S., Uchino E., Suetake N. Image boundary detection using the modified level set method and a diffusion filter. *Procedia Computer Science*. 17th International Conference in Knowledge Based and Intelligent Information and Engineering Systems. – 2013; 22:192–200.
2. Hussin R., Juhari M. R., Kang N. W., Ismail R. C., Kamarudin A. Digital image processing techniques for object detection from complex background image. *Procedia Engineering*. – 2012; 41:340–4.
3. Guyon C., Bouwmans T. and Zahzah E. H. Robust principal component analysis for background subtraction: Systematic evaluation and comparative analysis, – 2014.
4. Tareque M. H, Al Hasan A. S. Human lips-contour recognition and tracing. *International Journal of Advanced Research in Artificial Intelligence*. – 2014; 3(1):47–51.
5. Sujatha B., Santhanam T. Classical flexible lip model based relative weight finder for better lip reading utilizing multi aspect lip geometry. *Journal of Computer Science*. – 2010; 6(10): 1065–9.
6. Sreenivas D. K., Reddy C. S., Sreenivasulu G. Contour approximation of image recognition by using curvature scale space and invariant-moment based method. *International Journal of Advances in Engineering and Technology*. – 2014. – May; 7(2):359–71.
7. Yang C. et. al. “On-Line Kernel-Based Tracking in Joint Feature – 3 Spatial Spaces,” DEMO on IEEE CVPR, – 2004.
8. Zoran Zivkovic. Improved adaptive gaussian mixture model for background subtraction. In *Pattern Recognition, ICPR – 2004*. IEEE Proceedings of the 17th International Conference, – P. 28–31.

*Mamatov Farmon Murtozevich,
Karshi Engineering-Economics Institute, professor,
Head of the Department of scientific-applied researches
and Innovation, Republic of Uzbekistan,
E-mail: fmamatov50@mail.ru*

*Toshtemirov Sanjar Jumaniyazovich,
associat professor,
Karshi Engineering-Economics Institute,
Republic of Uzbekistan*

*Xoliyarov Yormamat Berdiqulovich,
candidate, of technical sciences, Senior Researcher,
Soil Processing Department,
Scientific Research Institute of Mechanization
and Electrification of Agriculture (SRIMEA), Tashkent*

*Batirov Zafar Lutfullayevich,
candidate, of technical sciences, Vice-rector
Karshi Engineering-Economic Institute,
Republic of Uzbekistan
E-mail: botirov1972@inbox.ru*

ENERGY-RESOURCE-SAVING TECHNOLOGY AND A MACHINE FOR PREPARING SOIL FOR PLANTING COTTON ON THE RIDGES

Abstract: The article describes the features and advantages of an energy-resource-saving new technology for the preparation of cotton fields for sowing cotton seeds on the ridges, as well as the technological process of work and the test results of the developed combined machine for implementing the proposed technology.

Keywords: technology, soil, machine, cotton, formation of ridges, hull, deep-looser, paraplane, ridge-maker.

Introduction. In Uzbekistan, the preparation of soil for cultivated cotton on the ridges is carried out mainly stepwise, i.e. single-operation machines in several passes, which in many cases is not justified agronomically. One-operation technology of soil preparation for sowing includes fertilization, plowing, preparation of soil for sowing (disking, harrowing, pounding, etc.). Then the cotton is sown [1, 27; 2, 12; 3, 86–88; 4, 125–126].

Multiple travel of machinery along the field being treated leads to an increase in undesirable soil compaction by the wheels of tractors and machines, which leads to a decrease in the yield of cotton. This treatment is not soil-protective and does not meet modern requirements [4, 125–126; 5, 234–235].

Thus, traditional technologies are not justified agronomically and economically, as labor productivity is reduced, labor and funds are expended, soil is compacted, soil preparation time is tightened, soil is intensively dried, which leads to a decrease in crop yields.

Proceeding from the above, agriculture needs new, more advanced technologies and means of mechanization for soil cultivation. At the same time, machines and units must meet the following modern requirements: provide a sharp (1.5–3 times) increase in labor productivity, a decrease in fuel consumption of more than 20%; energy intensity of operations performed by combined units should be lower than the total energy intensity of operations of the whole complex of single-operation machines;

labor costs for the operation of combined units should be lower than when the whole complex of replaceable single-operation machines [6, 6–8; 7, 28–29].

Objects and methods of research. The object of the research is the technology of preparation of cotton fields for comb-seeding and a combined machine for the implementation of this technology. The methods of system analysis and the rules of agricultural mechanics were used in the research.

The studies were conducted in 2016–2017 in Kashkadarya region of Uzbekistan. Type of soil – takyr. Background – a field of cotton. The average slope of the terrain is 1° . The microrelief is uneven, combed. The average height of the ridges is 15,8 cm. Humidity and soil hardness in horizons 0... 10, 10... 20, 20... 30 cm was respectively 8,2; 12,1; 14,5% and 2,86; 3,1; 3,38 MPa.

Results of the research. The Karshi Engineering and Economics Institute has developed a new technology and a combined machine for preparing soil for planting cotton on the ridges [8, 8; 9, 11].

The peculiarity of the new technology is that the preparation of cotton fields for cotton planting on ridges is carried out by forming new ridges instead of existing ridges (fig. 1). At the same time, first the top layer of the crest of each aisle is processed to the depth a_1 by wrapping the soil of the crest of the aux $abcd$ for 180° to its place (fig. 1a and b), then the lower layer of the soil is deeply loosened (fig. 1b) to the depth a_2 and locally fertilizers are introduced along the line of the middle of each ridge without disrupting its shape by a special working organ with a sloping “paraplu” type post [10, 35–37], equipped with loosening plates and fertilizer elements, after which crests are formed.

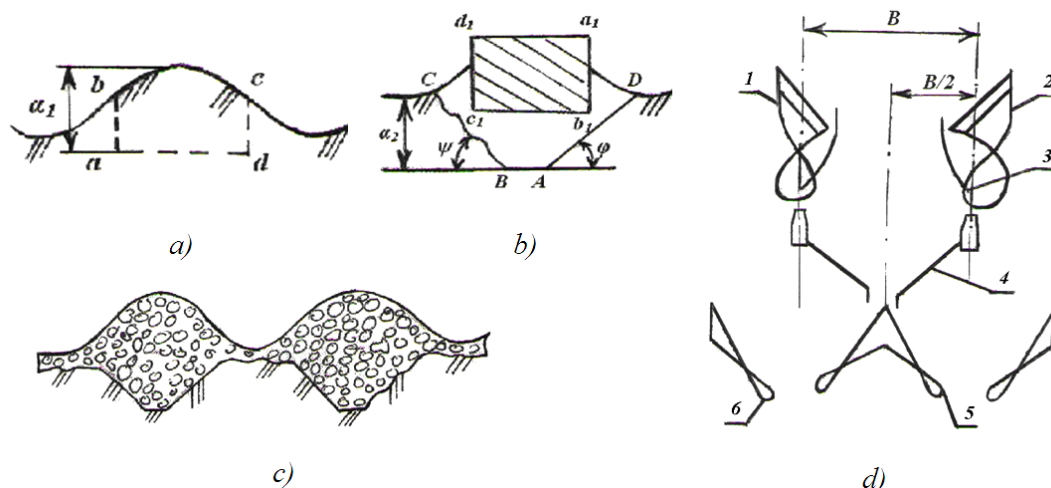

Figure 1. Scheme of technology and machines for preparing cotton fields for seeding on ridges

When the soil of the crest is rotated by 180° , seeds of weeds and plant debris are embedded in their place. The use of a new special working body with a sloping “paraplu” type support facilitates loosening of the old crest’s soil without moving and carrying soil aggregates to the surface, as a result of which the crests are not disturbed. At the same time, this working body locally makes fertilizers. The technology of crest formation instead of existing without moving soil in comparison with existing technologies requires much less energy.

The machine that carries out this technology contains the right – and the left-handed screw plow cases 1 and 2 with the plows 3, the deeper plows 4 of the “paraplu” type, equipped with loosening plates and fertilizer

elements, a fertilizer application device, two-sided 5 and one-side ridges 6 (Fig. 1 d).

On the basis of theoretical studies, an experimental sample of a combined machine was manufactured. During the tests, the machine loosened the soil under the ridges to a depth of 37.4 cm and formed a new crest with a height of 24.8 cm. The degree of loosening of the soil was 80,48%. The use of the combined machine reduces fuel costs by 46.72%, labor costs by 44.84% and operating costs by 60.4% compared to existing machines.

Conclusion. Studies have shown that the developed machine reliably performs the specified technological process, its performance is fully consistent with the agro-technical requirements.

References:

1. Маматов Ф. М., Мирзаев Б. С., Чуянов Д. Ш., Эргашев Г. Х. Агрегат для новой технология подготовки почвы под бахчевые культуры // Картофель и овощи.– Москва,– 2011.– № 1.– 27 с.
2. Маматов Ф. М., Мирзаев Б. С., Чуянов Д. Ш., Эргашев Г. Х. //Агрегат для предпосевной подготовки почвы // Сельский механизатор.– Москва,– 2011.– № 7.– 12 с.
3. Маматов Ф. М., Мирзаев Б. С., Авазов И. Ж. Агротехнические основы создания противоэрозионных влагосберегающих технических средств обработки почвы в условиях Узбекистана // Природообустройство.– Москва, – 2014.– № 4.– С. 86–88.
4. Mamatov F. M., Kodirov U. I. Energy-resource machine for preparing soil for planting root crops on ridges // European Science Review.– Vienna,– 2016.– No. 11–12.– P. 125–126.
5. Mamatov F. M., Shodmonov G. D., Chuyanov D. Sh., Ergashov G' Kh. New technology and combined machine for preparing soil for sowing gourds // European Science Review.– Vienna,– 2018.– No. 1–2.– P. 234–236.
6. Маматов Ф. М., Эргашев И. Т., Равшанов Х. А., Исломов С. И. Обоснование параметров механизма навески плуга на трактор//Механизация и электрификация сельского хозяйства.– Москва,– 2000.– № 11.– С. 6–8.
7. Маматов Ф. М., Эргашев И. Т., Исломов С. И. Комбинированный фронтальный плуг с активными рабочими органами// Механизация и электрификация сельского хозяйства.– Москва,– 2001.– № 8.– С. 28–29.
8. Mamatov M. F., Mirzaev B. S., Rashanov X. A., Temirova D. I., Aхзматов Б. Р., Кодиров У. И., Тоштемиров С. Ж. Способ подготовки почвы к севу сельскохозяйственных культур на гребнях и грядах // Patent of the Republic of Uzbekistan No. IAP 04832. Официальный бюллетень.– Ташкент,– 2014.– № 3.– 8 р.
9. Mamatov M. F., Mirzaev B. S., Rashanov X. A., Temirova D. I., Aхзматов Б. Р., Авазов И. Ж., Кодиров У. И., Тоштемиров С. Ж. Комбинированное почвообрабатывающее орудие // Патент на полезную модель UZ FAP 00672. Официальный бюллетень.– Ташкент,– 2011.– № 12.– 11 р.
10. Листопад Г. Е., Маматов Ф. М., Эргашев И. Т. Тяговое сопротивление почвоуглубителями с наклонной стойкой// Техника в сельском хозяйстве.– Москва,– 1991.– № 6.– С. 36–37.

*Mamatov Farmon Murtozevich,
Karshi Engineering-Economics Institute, professor,
Head of the Department of scientific-applied researches
and Innovation, Republic of Uzbekistan,
E-mail: fmamatov50@mail.ru*

*Ergashev Ismoil Toshkentovich,
professor, Samarkand Agricultural Institute, Samarkand*

*Mirzaxodjaev Sherzodxuja Shoxruxovich,
Senior lecturer, Samarkand Agricultural Institute, Samarkand*

*Xoliyarov Yormamat Berdiqulovich,
candidate, of technical sciences, Senior Researcher,
Soil Processing Department, Scientific Research Institute
of Mechanization and Electrification
of Agriculture (SRIMEA), Tashkent*

*Qurbanov Sherzod Baxtiyorovich,
Ph D., researcher, Department of agricultural mechanization,
Karshi Engineering-Economics Institute, Karshi*

PLOW FOR SMOOTH PLOWING WITH COMBINED WORKING BODIES

Abstract: There given the organization and principle of the functioning of the combined frontal plough with passive and active working parts, realizing smooth ploughing up by the reverse of layers within own furrow on 180° in this article.

Keywords: front plough, smooth tillage, the passive working parts, the active working parts, energy saturated wheeled tractor, efficiency of using power.

Introduction. When testing the front plows with passive working bodies carrying out a smooth, barefire plowing in the farms of the Republic of Uzbekistan, the problem of effective utilization of the power of energy-saturated wheeled tractors [1, 35–37; 2, 24; 3, 6–8]. It was found that the traction force developed by the tractors was not sufficient for all the soil-climatic conditions to operate at the required speeds because of their insufficient coupling weight. The problem is complicated by the fact that, due to the symmetrical location of the plow relative to the longitudinal axis of the tractor, its width of grip must be greater than the width of the tractor.

As the working speeds of the front plow with the passive working bodies increase, its traction resistance increases, which leads to the need to work on lower gears with incomplete engine loading and increased slippage of propellers. At low speeds, the technological process of turnover of beds is disrupted and the quality of plowing is sharply reduced [4, 86–88].

Objects and methods of research. The object of research is a plow for smooth plowing with combined working organs. The methods of system analysis and the rules of agricultural mechanics were used in the research.

Studies were conducted in the Kashkadarya region of Uzbekistan. Type of soil – light gray, medium loamy. Background – field from the winter wheat. The average slope of the terrain 1°. The relief is flat. Humidity and hardness of the soil horizontally 0 ... 10, 10 ... 20, 20 ... 30 cm was 8.75, respectively; 11.9; 15.5% and 3.43; 4.75; 5.4 MPa. The quantity of stubble residues is 0.895 kg/m², the stubble height is 9.1 cm.

Results of the research. To solve these problems, a front plow for smooth, unarmed plowing with active and passive working bodies has been developed (Fig. 1), in which the active working elements along with the technological functions will perform the functions of the propulsors and thus allow to unload the narrow link in the power transmission chain through the propulsor tractor,

as well as contribute to increasing the productivity and economy of the unit [5; 6, 28–29; 7, 10].

The technological process of the plow is carried out as follows: the knives of the active working organ 1 (Fig. 1) crush the plant remains and mix them with the upper layer of soil, going behind the active working organ plow bodies 2 with the plows 4 turn the beds into their furrow, laying the crushed vegetable Remnants to the bottom of the furrow. Roller 3 produces crushing of lumps and leveling of the soil surface.

When using this tool for plowing fields from perennial grasses with a powerful root system, the surface of

the wrapped formation is cut into bands with partial crumbling, as a result of which its elastic properties decrease and there is no reverse unwinding. When using active working organs in fields with a large amount of vegetation, cutting of plant residues and mulching them into the soil occurs, as a result of which the probability of plow plowing is reduced. When processing soils with insufficient moisture and high density of the knife of the active working organ, loosening the upper compacted and over-dried soil layer, improve the quality of crumbling.

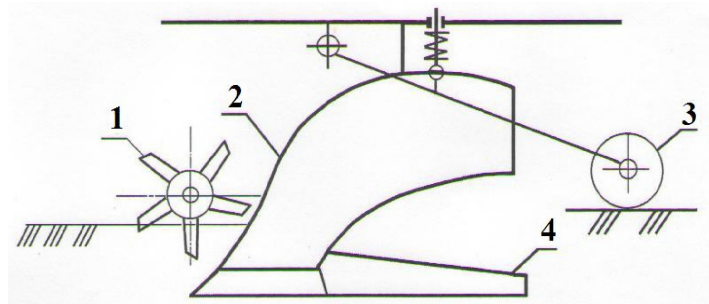

Figure 1. Scheme of plow for smooth plowing with passive and active working bodies

Rotating in the same direction as the tractor's propellers, the active working elements create a pushing force that compensates for the part of the traction resistance of the plow. Decrease in tractive resistance of the plow is also due to the fact that the plow bodies process the soil, the upper layer of which is broken up by active working bodies. With this arrangement of working bodies, a field of compressive stresses created by the body is superimposed on the stress field from the milling cutter, which is directed in the opposite direction. When a combination of stresses of different signs increases the degree of crumbling of the soil and reduces energy consumption [8, 61–70].

As a result of the studies, the following parameters and operating conditions of the active working element are justified: the drum diameter is 600 mm, the blade angle is 30°, the knife thickness is 10 mm, the knife sharpening angle is 20°, the number of blades on the disc is 4, the kinematic parameter (the ratio of the circumferential speed of the knife to the translational speed of the plow) $\lambda = 2.1$, transverse distance between knives 26 cm, longitudinal distance between the active working element and the body $l = 30$ mm.

Based on the studies carried out, an experimental plow sample was prepared for smooth plowing with

combined working organs. The plow tests showed that it reliably fulfills the given technological process, its performance indicators fully comply with the agrotechnical requirements.

Analysis of the obtained data shows that the installation of an active working element on the front plow contributes to an increase in soil crumbling by 18,3%, closing of plant residues by 9.1%, a decrease in the height of the ridges by 1.6 cm. The use of active tools has little effect on the stability of the course plow.

When installing active working tools, the drag of the front plow is reduced by 15.6%, and the coefficient of variation of the pull resistance is 1.42 times. Due to the reduction of the traction resistance, the tractor's skidding decreased and the working speed increased from 2,06 to 2.29 m/s. The increase in speed allowed to increase productivity by 11.3%. At the same time, the specific fuel consumption is reduced by 12.54%.

Conclusion. The carried out tests of the experimental sample of the front plow showed that the installation of active working elements on the plow contributes to the increase of soil crumbling, embedding plant residues and increasing the productivity of the unit.

References:

1. Лобачевский Я. П., Маматов Ф. М., Эргашев И. Т. Фронтальный плуг для хлопководства // Хлопок. – 1991. – № 6. – С. 35–37.
2. Маматов Ф. М., Эргашев И. Т., Равшанов Х. А. Мини-плуг для гладкой вспашки // Аграрная наука. – 2003. – № 1. – 24 с.
3. Маматов Ф. М., Эргашев И. Т., Равшанов Х. А., Исломов С. И. Обоснование параметров механизма навески плуга на трактор // Механизация и электрификация сельского хозяйства. – Москва, – 2000. – № 11. – С. 6–8.
4. Маматов Ф. М., Мирзаев Б. С., Авазов И. Ж. Агротехнические основы создания противоэрозионных влагосберегающих технических средств обработки почвы в условиях Узбекистана // Природообустройство. – 2014. – № 4. – С. 86–88.
5. Сакун В. А., Листопад Г. Е., Маматов Ф. М., Лобачевский Я. П., Максименко М. С., Темиров И. Г. Способ вспашки почвы // А.с.1727594. Б.И. – Москва, – 1992. – № 15.
6. Маматов Ф. М., Эргашев И. Т., Исломов С. И. Комбинированный фронтальный плуг с активными рабочими органами // Механизация и электрификация сельского хозяйства. – Москва, – 2001. – № 8. – С. 28–29.
7. Маматов Ф. М., Эргашев И. Т., Мирзаев Б. М., Мирзаходжаев Ш. Комбинированный фронтальный плуг // Сельский механизатор. – 2011. – № 10. – С. 10–11.
8. Панов И. М. Методы повышения эффективности обработки почвы // Труды НПО ВИСХОМ. – Москва, – 1990. – С. 61–70.

*Mamatov Farmon Murtozevich,
professor, Karshi Engineering-Economic Institute,
Head of the Department of scientific-applied
researches and Innovation,
E-mail: fmamatov50@mail.ru*

*Batirov Zafar Lutfullayevich,
candidate, of technical sciences, Vice-rector,
Karshi Engineering-Economic Institute,
Republic of Uzbekistan
E-mail: botirov1972@inbox.ru*

*Halilov Muhtor Suvonovich,
senior lecturer, Republic of Uzbekistan
Karshi Engineering-Economic Institute,
E-mail: halilov-m@qmii.uz*

CHISEL–CULTIVATOR-FERTILIZER FOR FORMING RIDGES AND APPLYING FERTILIZERS

Abstract: A new fertilizer application technology for cotton crops and a chisel-cultivator-fertilizer is presented, equipped with fertilizer coulters to form ridges and local application of fertilizers to the zone of activity of the root system of cotton.

Keywords: technology, fertilizer, cotton, chisel, fertilizer, vomer, comb, layer-by-layer application, yield.

Introduction. The use of mineral and organic fertilizers as the main factor of increasing crop yields in agriculture in recent years has been given increasing importance. Science and practice have proved beyond any doubt that at least half of the increase in crop yield is obtained through the use of fertilizers [1, 353–372; 2, 201–223; 3, 25–33].

For the best provision of the plants' needs in mineral nutrition, a system of layerwise fertilizer placement in the soil is used in separate phases of their development, consisting of three links: the main and sowing application, as well as the fertilizing of plants. In this case, the layered arrangement of the fertilizer in the soil is carried out in several ways, each of which has definite goals and tasks. It is known that at present most of the annual norm (about 70%) of phosphorus is recommended to be applied for plowing with a two-tier plow. At the same time fertilizers are embedded deep. Naturally, under such conditions, young cotton plants with a poorly developed root system in the first period of life almost do not use phosphorus fertilizers, which were brought under plowing.

In addition to the traditional methods of preparing soil for sowing reduce labor productivity, increase the expenditure of labor and resources, compaction of soil, delay the preparation of soil, intensively dry the soil, which leads to a decrease in the yield of agricultural crops. It is established that the more promising technologies are those that prepare the soil for sowing and fertilization in one pass of the unit [4, 12–14; 5, 27; 6, 125–126].

Objects and methods of research. The object of research is fertilizer application technology and a chisel-cultivator-fertilizer with a fertilizer coulters for applying fertilizers and forming ridges. The methods of system analysis and the rules of agricultural mechanics were used in the research.

The studies were conducted in 2012–2017 in the Kashkadarya region of Uzbekistan. Background – a field from under cotton. Type of soil – light gray. The average slope of the terrain 10. Humidity and hardness of the soil horizontally 0 ... 10, 10 ... 20, 20 ... 30 cm were 12.7; 14.9; 15.8% and 2.43; 2.94; 3.21 MPa.

Results of the research. It is known that cotton consumes a small amount of nutrients in the early periods of life; nevertheless, for its normal growth and development it is necessary to have them in the soil solution in a slightly increased concentration and in a certain ratio. In the initial stage of cotton development during the period of butanization and in subsequent periods, when there is a shortage of nitrogen in the soil, especially phosphorus, the yield is sharply reduced even with increased feeding of plants. At the same time, the efficiency of fertilizer use is reduced, since from the moist soil the plants absorb fertilizer nutrients 5 times more than from dry soil [2, 104–129].

The applied fertilizer application system has a number of significant drawbacks. It does not meet the basic principle of agrochemistry “feed plants not the soil.”

Scientists of the Uzbek Research Institute of Mechanization and Electrification of Agriculture and Karshi Engineering -Economics Institute proposed a new method of cultivating cotton, which ensures maximum use of fertilizers [7, 242–243].

The essence of the proposed method is as follows: in autumn, after harvesting the stems of cotton, in the places of sowing rows, loosening is carried out at a depth of 18 ... 20 cm, where mixtures of mineral and organic fertilizers are introduced in the form of a strip 15 ... 20 cm wide and ridges are formed. In the spring, the soil is treated on the ridges and sowing. In this case, instead of the most laborious plowing operation, a deep loosening (or chilling) is carried out with the simultaneous application of fertilizers and the final formation of ridges. The proposed method, depending on the soil and climatic conditions, can be carried out by a chisel-cultivator-fertilizer ЧКУ-4М (Fig. 1) with a device for applying fertilizers in rows of soil with a row spacing of 60 or 90 cm, equal to the inter-crop of cotton. To reduce the traction resistance, ahead of the fertilizer coulters 4, ЧКУ-4М is equipped with rippers 3. To form ridges, hillocks or combers are installed in it. Depending on the condition of the soil, if necessary, rippers are additionally installed in front of the hillers.

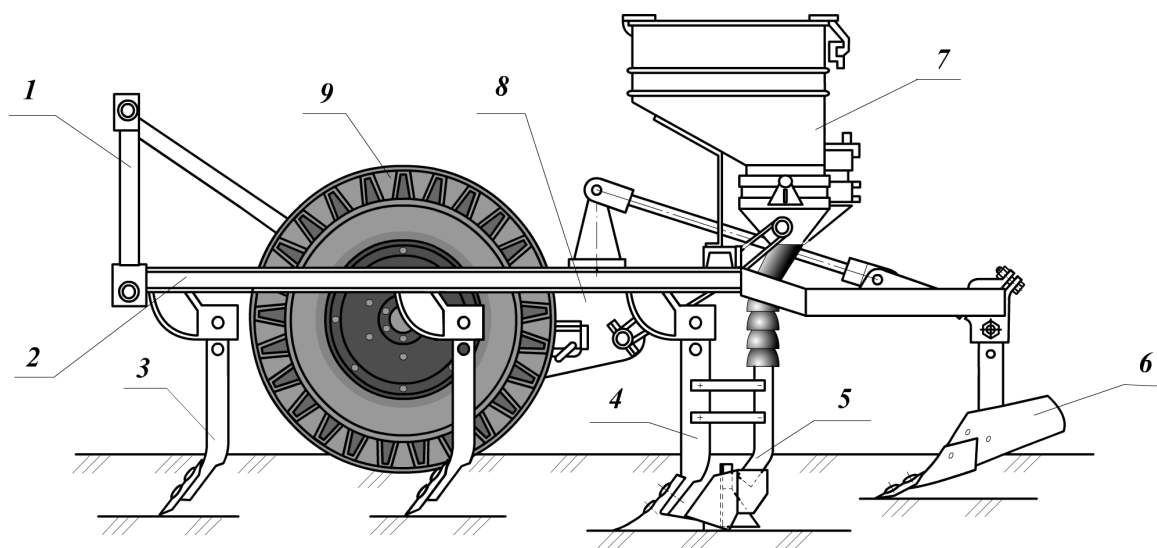

Figure 1. Scheme of the chisel-cultivator-fertilizer: 1 – lock automatic hook; 2 – frame; 3 – ripper; 4 – fertilizer coulter; 5 – fertilizer hose; 6 – hiller; 7 – the traction apparatus; 8 – the regulator of depth; 9 – support wheel

During the winter, the soil treated with such an aggregate naturally thickens and settles. Its density will be equal to the density of the soil prepared for sowing. In spring they are band-processed on the ridges. And sowing is carried out without applying fertilizers. As a result, in the autumn, the continuous application of fertilizers for plowing is excluded. During the early spring harrowing with leveling, chewing is carried out with the introduction of fertiliz-

ers and the simultaneous formation of ridges. In this case, cotton, depending on the development of the root system, feeds on fertilizers located on the ridge at a certain depth. In addition, in this way the root system of cotton covers the introduced fertilizers with a larger surface, which will increase the utilization factor of their plants.

On saline soils, this method is used after washing irrigation. Adapted chisel-cultivator ЧКУ-4М or ridge-filler ГХ-4

make fertilizers and simultaneously form ridges. After natural subsidence and compacting of the soil, cotton is planted.

To determine the effectiveness of the new technology, agrotechnical experiments were conducted in 2008–2016 on the fields of farms in the Kashkadarya region of Uzbekistan. At the same time, the formation of ridges with a spacing of 90 cm and fertilization was carried out by the modernized chisel-cultivator ЧКУ-4М. The results of the research showed that with the new fertilizer application technology at a depth of 16 ... 18 cm with a strip width of 20 cm (simultaneously with the formation

of ridges on the plowed field), the yield of raw cotton was raised to 8 hundredweights per hectare in comparison with the existing technology. Productivity of the unit is increased by 2.8 times, fuel consumption is reduced by 1.9 times.

Conclusion. The technology of preparing the soil for sowing on the ridges on the plowed field and the local application of fertilizers to cotton in the zone of activity of its root system by the modernized chisel-cultivator promotes the effective use of fertilizers and, correspondingly, the increase in the yield of cotton.

References:

1. Прянишников Д. Н. Значение химизации, поднятия наших урожаев и придание им устойчивости: Труды АН России.– Москва,– 1986.– 410 с.
2. Соколов А. В. Распределение питательных веществ в почве и урожай растений.– Москва: Изд-во АН России,– 1987.– 328 с.
3. Батиров З. Л., Шахобов С. Ш. Машины для внесения удобрений под посевные рядки хлопчатника.– Карши: Насаф,– 2008.– 98 с.
4. Маматов Ф. М., Мирзаев Б. С., Чуюнов Д. Ш., Эргашев Г. Д. Агрегат для предпосевной подготовки почвы // Сельский механизатор.– Москва,– 2011.– № 7.– С. 12–14.
5. Маматов Ф. М., Мирзаев Б. С., Чуюнов Д. Ш., Эргашев Г. Д. Агрегат для новой технологии подготовки почвы под бахчевые культуры // Картофель и овощи.– Москва,– 2011.– № 1.– 27 с.
6. Mamatov F. M., Kodirov U. I. Energy-resource machine for preparing soil for planting root crops on ridges // European Science Review.– Vienna,– 2016.– No. 11–12.– P. 125–126.
7. Маматов Ф. М., Ботиров З. Л., Халилов М. С. Технология внесения минеральных удобрений в зону деятельности корневой системы хлопчатника // Молодой учёный.– Казань,– 2013.– № 11 (58).– С. 242–243.

Mirsagdiyev Orifjon Alimovich,
 assistant, of the Department
 "Electrical connection and radio",
 Tashkent Institute of Railway Transport Engineering
 E-mail: oamirsagdiyev@yandex.ru

EVALUATION OF THE QUALITY OF VOICE TRANSMISSION IN THE NETWORK OF AN OPERATIVE TECHNOLOGICAL NETWORK WITH PACKET SWITCHING

Abstract: Today the networks of operational and technological communications are built using digital channel switching systems. In the future, operative technological network (OTN) networks should implement packet-switching systems. The transition to packet technologies leads to a change in the conditions for voice transmission, so it is necessary to analyze the quality of voice transmission in the prospective OTN networks.

Keywords: operative-technological communication networks, packet switching, voice quality, E-model.

Compared with OTN digital networks with channel switching in packet switched networks, it is possible to distinguish the following features of network construction from the point of view of voice transmission: a central conference server is used; speech transformation can occur in many ways, including coding with accumulation of speech elements with linear prediction; VAD voice activity detectors can be included in conversational tracts.

The quality of voice transmission is estimated by the integral indicator – R factor, which is calculated using

the E-model. On the basis of the R-factor, the subjective indicator of the quality of voice transmission is determined – MOS (Mean Opinion Score).

For the calculation of the R-factor and the MOS index, the methodology given in recommendations [1 and 2] and described in [3, 4, 5] is used.

Let's estimate the quality of voice transmission in the circle of the train dispatch communication (TDC). Figure 1 shows a diagram of the organization of a TDC circle in a packet-switched network. It shows only the elements associated with the transmission of speech.

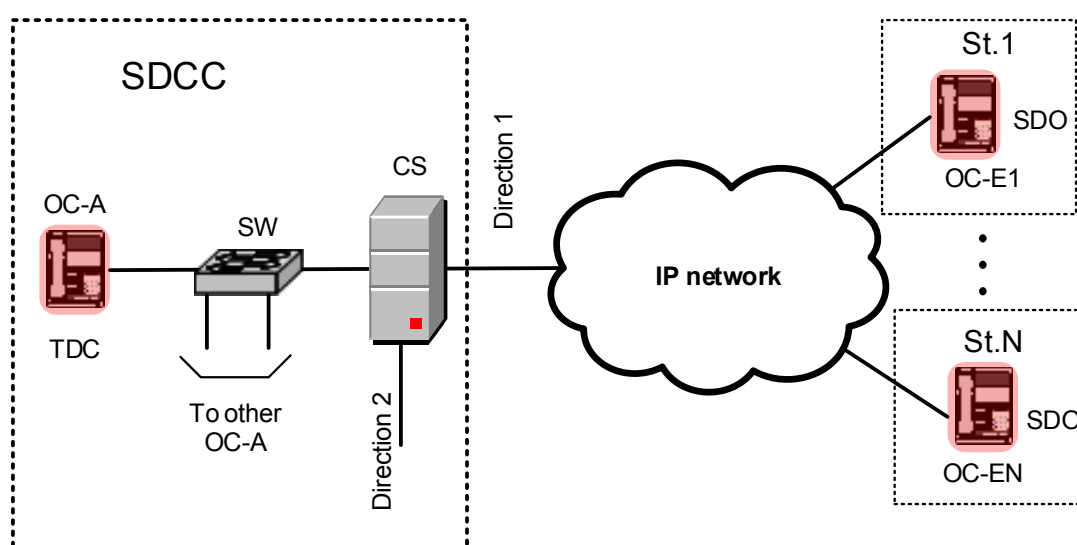

Figure 1. Organization of a TDC circle in a packet-switched network

The train dispatch of the circle is in the Single Dispatch Control Center (SDCC), and the duty attendants subordinate to him – at stations 1 ... N, as well as at other stations of direction 2. Each TDC subscriber has one operational console (OC) interworking console, and the dispatcher has a administrative console (OC-A), and the duty officer has an executive console (OC-E) type. The OC is an IP phone that performs the specific functions of the OTN. There are a SDCC conference server (CS) and

a switch (SW), which is used for combining the control console of all dispatchers of the SDCC. The CS server is connected to the station consoles 1 ... N by the IP network, which includes, first of all, routers and switches. The network in question uses Ethernet channels.

In (Figure 2), for the considered TDC circle, a diagram of the colloquial path formed between the OC-A and the OC-E is shown. Voice transmission can occur in both directions in half-duplex mode.

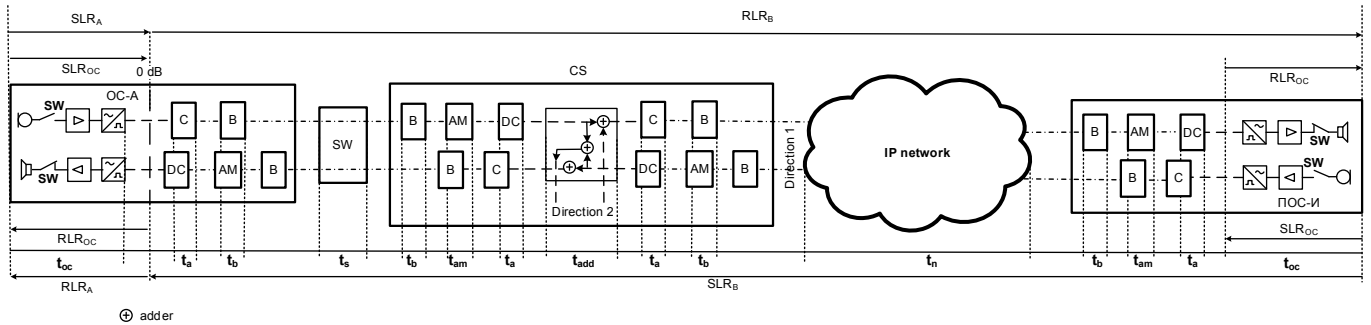

Figure 2. Scheme of the colloquial tract formed between the OC-A and the OC-E

The structure of the panels and CS includes: a coder (C), a decoder (DC), an adaptation module (AM) and buffers (B). The coder and decoder form a codec that converts speech in the form of a speech wave or a hybrid one in which linear prediction and speech waveform coding are combined. The first codecs include: G.711 and G.721, using pulse-code modulation (PCM) and additive differential PCM (ADPCM), respectively. Hybrid codecs make up the G.72X group, among which G.723.1, G.728 and G.729 codecs are often used.

The adaptation module serves to smooth out the jitter in the speech reception path, while AM accumulates several speech packets. The buffers serve to form the queue of packets when receiving and transmitting. The CS includes digital adders that provide a mode of conferencing and distribution of voice packets in different directions of communication.

Two variants of construction of CS are considered: with adaptive and non-adaptive adders. In the first case, a speech detector is installed at each input of the adder. In it, the summation process occurs when there are speech signals on two or more inputs of the totalizers.

If the signal is only on one input, then the adder sends it to the output without any transformations. A non-adaptive adder does not have a speech detector and summation occurs even if the speech signal is present

only on one input. At the same time, distortion is introduced into the speech signal.

In all the variants of voice transmission, the following indicators are adopted: masking of the local effect – $STMR = 15 \text{ dB}$, local effect for the listener – $LSTR = 18 \text{ dB}$, D – factor for the subscriber device in transmission and reception – $D_s = D_r = 3$, threshold noise on the side reception – $N_{for} = -64 \text{ dB}$, room noise on the transmitting and receiving sides – $P_s = P_r = 35 \text{ dB}$, the advantage factor – $A = 0$.

First, we determine the quality of the transmission with adaptive adder in an individual conversation between the train dispatch communication (TDC) and one station duty officer (SDO), assuming that the speech is transferred from the TDC to the SDO.

Each console is characterized by volume levels: for the transfer $SLR_{oc} = 7 \text{ dB}$ and for the reception $RLR_{oc} = 3 \text{ dB}$. In the talk channel in the direction from OC-A to OC-E, the volume level for transmission is: $SLR_A = SLR_{oc}$, receive volume level: $RLR_B = RLR_{oc}$. Volume levels in the opposite direction will be the same:

$$SLR_B = SLR_{pos} = 7 \text{ dB}; RLR_A = RLR_{oc} = 3 \text{ dB}.$$

The values of the echo reduction level for the speaker TELR and the attenuation of the weighted echo WEPL are determined by the following formulas:

$$TELR = SLR_A + RLR_A + a_{ta} = 7 + 3 + 75 = 85 \text{ dB} \quad (1)$$

$$WEPL = 2a_{ta} = 150\partial B, \quad (2)$$

a_{ta} – the transient attenuation between the receiving and transmitting paths inside the OC, the value of a_{ta} is assumed equal to 75 dB.

The magnitude of the quantization distortion $qdu = 1$.

Taking into account that adaptive adders are used in the conference server, the noise of one direction does not fall into the channel of the other direction of communication. Then the noise level at 0dB: $N_c = -70dB$.

During the formation, transmission and processing of speech packets in the talk channel, the following delays appear: t_a – accumulation delay in the codec (coder or decoder); t_b – delay in the receive or transmit buffer; t_{add} – delay in the adder; t_{am} – delay in AM; t_n – delay in the IP-network; t_{oc} – delay in the OC; t_s – delay in the switch.

In the calculations the following ratios of the delay times are accepted: $t_b = t_a$; $t_{am} = 2t_a$. The accumulation delay t_a depends on the type of codec. The duration t_n is a variable, depending on the extent and number of elements of the IP network through which the connection is established. In accordance with [2], the time $t_{oc} = 1.5$ ms and $t_{add} = 1$ ms. The delay in the switch t_k can be assumed to be zero.

Consider the options for voice transmission with codecs G.711 and G.729. In both cases, the accumulation delay t_a is assumed to be 10 ms. Variants differ in the hardware distortion index I_e , which is equal to: for codec G.711–0, and for codec G.729–10.

Total delay time in the conversation:

$$T = 2t_{oc} + 4t_a + 4t_b + 2t_{am} + t_{add} + t_s + t_n = 3 + 40 + 40 + 40 + 1 + t_n = 124 + t_n \text{ (MC)} \quad (3)$$

The parameter t_n includes delays in the nodes of the IP network, and also the propagation time of the signal, depending on the length of the communication channel within the IP network. The value of t_n depends to a large extent on how the IP network is constructed, on the number of switching nodes, and on the length of the IP network. In networks with packet technology, the quality of transmission can be significantly affected by the probability of loss of Ppl voice packets. Usually Ppl varies from 1% to 5%.

Let us analyze how the quality of voice transmission depends on the time t_n and the probability of loss of voice packets in the IP network Ppl.

Table 1 shows the calculated values of the R and MOS indicators in the transmission of speech from the TDC to the SDO with adaptive summers in the talk channel, depending on t_n and Ppl.

It should be noted that the actual scheme of speech transmission differs from the E-model. This is because the speech signal reflected at the receiving point is transmitted in the opposite direction and enters the input of the adder having the speech detector. Due to the low level of the reflected speech signal, the speech detector will evaluate it as noise and not pass it to the output. The subscriber at the transmission point will not hear the reflected signal. This feature can lead to improved voice quality. However, due to the fact that the TELR and WEPL parameters are large enough, the transmission quality estimate will not practically differ from that given in (Table 1).

Table 1.

t_n, ms	Ppl, %	T, ms	Codec G.711		Codec G.729	
			R	MOS	R	MOS
15	1	139	92.4	4.40	82.4	4.11
	2		92.6	4.40	82.2	4.10
	5		91.3	4.37	81.6	4.08
45	1	169	91.7	4.38	81.8	4.09
	2		91.5	4.37	81.6	4.08
	5		90.9	4.36	81.0	4.06
85	1	209	88.5	4.31	78.6	3.97
	2		88.3	4.30	78.4	3.96
	5		87.7	4.28	77.8	3.94
165	1	289	78.5	3.97	68.5	3.53
	2		78.3	3.96	68.3	3.52
	5		77.6	3.93	67.7	3.49

It should be noted that the actual scheme of speech transmission differs from the E-model. This is because the speech signal reflected at the receiving point is transmitted in the opposite direction and enters the input of the adder having the speech detector. Due to the low level of the reflected speech signal, the speech detector will evaluate it as noise and not pass it to the output. The subscriber at the transmission point will not hear the reflected signal. This feature can lead to improved voice quality. However, due to the fact that the TELR and WEPL parameters are large enough, the transmission quality estimate will not practically differ from that given in (Table 1).

Now consider a variant with non-adaptive adder in the collision path of the TDC circle.

In this case, speech conversion takes place in the adder, therefore it is assumed: for codec G.711 – $q = 2$,

$I_e = 0$, for codec G.729 – $q = 2$, $I_e = 20$. When calculating the noise in the Nc channel, it is necessary to take into account the branch formed in direction 2. The noise increases and amounts to: $N_c = -67\text{dB}$. The remaining parameters remain the same.

The results of the calculation for the transfer of speech from the TDC to the SDO for the variant with non-adaptive adders are given in (Table 2). Since the MOS value depends little on the probability of packet loss Ppl, calculations are made only for two values of this probability.

The quality of voice transmission in the opposite direction, from TDC to the SDO, in both variants of construction of adders will be the same, which is explained by the inclusion of identical OC consoles on the ends of the conversational paths.

Table 2.

t_n , ms	Ppl, %	T, ms	Codec G.711		Codec G.729	
			R	MOS	R	MOS
15	1	139	90.7	4.36	70.7	3.63
	5		89.8	4.33	70.0	3.60
45	1	169	89.9	4.34	69.3	3.56
	5		88.4	4.30	68.6	3.53
85	1	209	86.5	4.24	66.5	3.43
	5		85.0	4.20	65.2	3.37
165	1	289	76.1	3.87	56.2	2.90
	5		75.3	3.83	55.5	2.87

Conclusion

1. In all cases, the quality of voice transmission is almost independent of packet loss with a loss probability of not more than 5%.

2. The use of G.711 codecs in comparison with G.729 codecs allows to improve the quality of voice transmission, and in the variant with adaptive adder, the quality is improved by (7–8)%, and in the variant with nonadaptive adders – by (20–60)%.

3. High quality of voice transmission is achieved when using adaptive adders, and it is the same in dispatching circles with different subscriber devices – both consoles and analog telephones. In this case, in accordance with the existing categories of voice quality [3], G.711 codecs achieve a high category, and G.729 codecs are of medium category.

4. When using non-adaptive adders, the transmission quality is reduced. For PDS with G.711 codecs, depend-

ing on the length of the circle, you can achieve an average or high quality category, and with G.729 codecs, the quality will correspond to an unacceptable or a low category. If the subscribers of dispatcher communications have analog telephone sets, the quality is significantly dependent on the direction of voice transmission. When transferred from the controller to the subscriber with G.711 codecs, it is judged to be an unacceptable category. With G.729 codecs, voice quality is unacceptably low. Such a low quality is explained by the small value of the TELR parameter. In the direction of transmission from the subscriber to the dispatcher, the transmission quality becomes higher: with the G.711 codecs, the middle or high category; with codecs G.729 – basically low or middle categories.

5. To achieve voice quality not lower than the middle category ($MOS \geq 3.6$), OTN packet networks must be built on the basis of conferencing servers with adaptive

adders. In the conversational tracts of dispatching circles, it is better to use the G.711 codecs, which will almost always give the quality of the highest or highest category. It is important to note that the standard subscriber gateways AG can be used in the OTN network with adaptive

adders, which will significantly affect the cost of OTN systems. OTN networks with nonadaptive adders can be built only with the use of specialized gateways, in the subscriber terminals of which speech detectors should be used.

References:

1. Recommendation ITU-T G.107. The E-model: a computational model for use in transmission planning.– 2009.
2. Recommendation ITU-T G.108. Application of the E-model: A planning guide.– 1999.
3. Лебединский А. К. Оценка качества передачи речи в сетях коммутации каналов и пакетов.– Автоматика, связь, информатика,– 2011.– № 11.– С. 6–9.
4. Лебединский А. К. Мирсагдиев О. А. Оценка качества передачи речи в сети ОТС.– Автоматика, связь, информатика,– 2012.– № 7.– С. 2–5.
5. Рахмангулов А. Н., Мирсагдиев О. А. Имитационная модель оценки качества передачи речи в сетях оперативно технологической связи на железнодорожном транспорте.– Вестник МГТУ им. Г.И. Носова,– 2015.– № 2.– С. 12–20.

*Pirmatov Nurali Berdiyevich,
doctor, of Engineering, Professor,
Head of the Department of Electric
Machines at Tashkent State Technical University*

*Panoyev Abdullo Tilloyevich,
Ph D., candidate, (person working for doctor's degree)
of the Department Electric Power Industry
at Bukhara Engineering-Technological Institute,
Bukhara City, K. Murtazayev Str., house 15,
E-mail: panoev_abdullo@mail.ru.*

CALCULATION OF MECHANICAL CHARACTERISTICS OF INDUCTION MOTOR USED IN TEXTILE MACHINERY AT THE ENTERPRISE RUSHAN TEKS IN BUKHARA CITY

Abstract: In given article the mechanical characteristic of an induction motor with a squirrel-cage rotor of the type 4A100L6Y3 with a power of 2.2 kW, 220/380 V voltage, a rotation speed of 950 rpm of the loom of the textile enterprise «RUSHAN TEKS» in the city of Bukhara is calculated.

Keywords: asynchronous motor, mechanical characteristics, starting torque, sliding, critical moment, rated torque, loom.

Looms are improving in our country more and more. The textile industry alone is complex and diverse. The cotton fabric manufacture is one of the main industrial sectors. Chemical fibre production, as well as cotton fibre, is developing in Uzbekistan. It allows us to extend the raw materials base of textile industry of the Republic of Uzbekistan and to expand the range of output products. Depending on the principles of fabric formation, the looms are divided into continuous and periodic looms. The continuous looms can be multi-wave and circular. The circular looms produce only baggy fabrics. Looms are not yet commonly used in the weaving industry due to the complexity of the machine structure and limited type of fabric produced. Depending on mechanism installed on the loom, there are: cam shedding, dobbie and Jacquard looms. The cam shedding mechanism of the loom is the simplest, and is used in weaving cloths and fabrics with broken twill. Depending on the method of weft insertion, shuttle looms are divided into mechanical and automatic looms. The shuttle looms of AT type (fully automatic loom): AT-120, AT-175 (120, 175 – material width, cm). Depending on the method of weft insertion, weft looms are divided into mechanical and automatic looms. The shuttleless looms of CTБ type

(shuttleless weaving loom): CTБ 1–180, CTБ 1–220, CTБ 1–250, CTБ 1–330; CTБ 2–220, CTБ 4–330. The number after the letters indicates the number of types of filling yarns. The air-jet looms are produced under the names P-105, P-125 etc. Looms with pneumatic rapier are tagged ATIP-120, ATIP-140. The speed of looms can be different depending on the method of picking, material width and the structure of some mechanisms. Weaving looms consist of mechanism and components and each of them has its own function. All mechanisms and components of the loom are driven by an electric motor. Mechanical power is transmitted from the electric motor by a special device (drive). Mechanisms transmitting motion from the motor to the operating device are called drives. Mechanisms used in looms depending on their design are divided into the following groups: lever, cam, gear, screw and wedge, friction, with a flexible link, hydraulic, pneumatic and electronic mechanisms. Each type of drive is characterized by the transmission speed and the number of gears. Each transmission mechanism has two main components: a drive and a driven link. In multiple-reduction drives, the spacer link is placed between the drive and the driven link. One of the most commonly used electric motors in looms are

induction motors. Three-phase squirrel-cage induction motors 4A100L6Y3, 4A100S4Y3, 4A112MA6Y3, 4A1PM06Y3, 4A1PM11B6Y3 etc., have been installed in the looms of type CTБ used at the RUSHAN TEKS Enterprise today. Their power is 2.2 kW-4 kW and voltage-220/380 V. The electromagnetic torque may come from sources of two kinds, i.e: a) through electromag-

netic force and b) electromagnetic power. Below we will examine them in detail. The electromagnetic torque in an induction motor is created by the interaction between the rotating magnetic field produced by the alternating current in the stator windings ($I_2 \cos \psi_2$), i.e. according to the Ampère's force law an electromagnetic force is generated with magnetic flux, $\Phi_{max} F_{em} = B_{\delta} l i$ (Fig. 1).

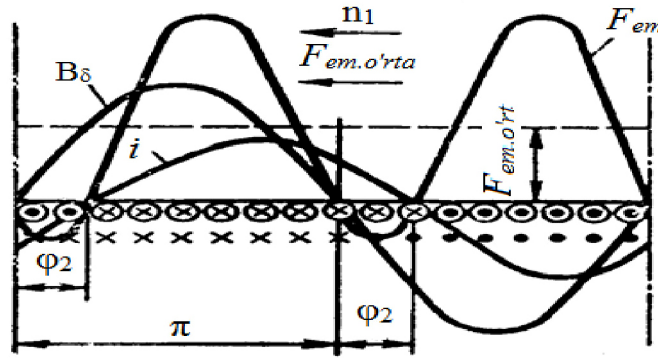

Figure 1. Curves of distribution of electromagnetic forces (F_{em}) influencing magnetic induction of the air gap of the motor (B_{δ}), the current in the rotor winding (i) and winding conductors of the induction motor

The electromagnetic torque created by this force is determined as follows:

$$M = C_M \cdot \Phi_{max} \cdot I_2 \cdot \cos \psi_2 \quad (1)$$

where: $C_M = p \cdot m_2 \cdot k_{ch2} / \sqrt{2}$ is the constant; Φ_{max} – is the maximum value of the magnetic flux. The equation (1) is valid not only for induction motor, but also for all types of electric machines. This equation establishes a link between torque and physical events happening in the machine. Its use is very convenient in the qualitative process analysis in different modes. But the values (Φ_{max} , I_2 and $\cos \psi_2$) included in this equation are not directly related to the supply-line voltage and machine operating conditions, and their experimental observation is very complex. For this reason the following equation has been derived, which allows to define the value of an electromagnetic (running) torque in the simplest way, to take into account influence of various parameters and operating modes of the machine. We express the electromagnetic (P_{em}) and mechanical (P_{mex}) powers defined in the power diagram through the electromagnetic torque:

$$P_{em} = M \cdot \omega_1; P_{mex} = M \cdot \omega, \quad (2)$$

where:

$$\begin{aligned} \omega_1 &= (2 \cdot \pi \cdot n_1 / 60) \cdot (p / p) = \\ &= (2 \cdot \pi / p) \cdot (p \cdot n_1 / 60) = 2 \cdot \pi \cdot f / p; \end{aligned}$$

and $\omega = 2 \cdot \pi \cdot n / 60$ is the angular velocity of the rotating magnetic field in stator and rotor respectively. According to the (2), the electromagnetic torque is equal to:

$$M = P_{em} / \omega_1 \quad (3)$$

Thus, the electromagnetic torque in the induction motor is proportional to its electromagnetic power. Using the power diagram, we can specify the following expressions to determine the losses in the rotor winding:

$$P'_{e2} = P_{em} - P_{mex} \quad (4)$$

$$\text{or } P'_{e2} = M \cdot \omega_1 - M \cdot \omega = M \cdot (\omega_1 - \omega). \quad (5)$$

Multiplying the right side of the equation (5) by the ratio (ω_1 / ω_1) we find the following: $P'_{e2} = M \cdot \omega_1 \cdot S$. (6)

From this equation (6) we have

$$M = P'_{e2} / (\omega_1 \cdot S) = m_1 \cdot (I'_2)^2 \cdot r'_2 / (\omega_1 \cdot S), \quad (7)$$

i.e. the electromagnetic torque in the induction motor is proportional to its power of electric losses in the rotor winding. Using a G-shaped replacement circuit, substituting the value of the rotor current I_2 to the (7) in view of $\omega_1 = (2 \cdot \pi \cdot f_1) / p$, we have the general electromagnetic torque equation of the induction motor::

$$\begin{aligned} M &= (m_1 \cdot p \cdot U_1^2 \cdot r'_2) / \{2 \cdot \pi \cdot f_1 \cdot S \cdot \\ &\cdot [(r_1 + r'_2 / S)^2 + (x_2 + x'_2)^2]\}. \end{aligned} \quad (8)$$

This (8) equation implies that for the induction motor with a power of $P > 10$ kW in the calculation of the

M moment, the complex number in the replacement diagram is assumed as $c_1 \approx 1$. If it is necessary to calculate the electromagnetic torque more precisely, the expression (8) taking into account the complex number c_1 is written as:

$$M = (m_1 \cdot p \cdot U_1^2 \cdot r'_2) / \{2 \cdot \pi \cdot f_1 \cdot S \cdot [(r_1 + c_1 \cdot r'_2 / S)^2 + (x_1 + c_1 \cdot x'_2)^2]\}, \quad (8, a)$$

where $c_1 \approx 1,02 \div 1,05$ – is for the induction motors with a power of $P \leq 10 \text{ kW}$

In expressions (8) and (8, a), all values other than slip S are constant, and the slip varies directly as the mechanical load on the shaft. One of the main characteristics of the three-phase squirrel cage induction motor is the mechanical characteristic. Depending on the specific boundaries of this characteristic, we can define the operating conditions of the induction motor. Boundary of steady-state performances of this characteristic are usually determined by the Kloss formula:

$$M = 2 \cdot M_{kp} / (S / S_{kp} + S_{kp} / S), \quad (9)$$

where M – is the electromagnetic torque; M_{kp} – is the critical moment; S – is the slip; S_{kp} – is the critical slip. The mechanical characteristic of the induction motors can also be calculated using directory values and reference data. At the same time, the torque characteristic is defined by 4 points and the mechanical characteristic of the induction motor is calculated (Fig. 2). Point 1- is the no load operation of induction motor, where $n = n_0 = 60 \cdot f / p$, $M = 0$, where f – is the rotor frequency; p – is the number of pole pairs.

Point 2 – is the rated power setting of induction motor, where $n = n_0$, $M = M_n = 9550 \cdot P_n / n_n$, where P_n – is the rated motor output, kW;

Point 3 – is the critical moment, where $n = n_{kp}$, $M = M_{kp} = \lambda \cdot M_n$;

Point 4 – is the starting torque, $n = 0$, $M = M_{н.т} = \beta \cdot M_n$.

Figure 2 shows the calculation and construction of the mechanical characteristics used in looms with three-phase squirrel-cage induction motor of the type 4A100L6Y3 with a power of 2.2 kW, 220/380 V voltage, a rotation speed of 950 rpm.

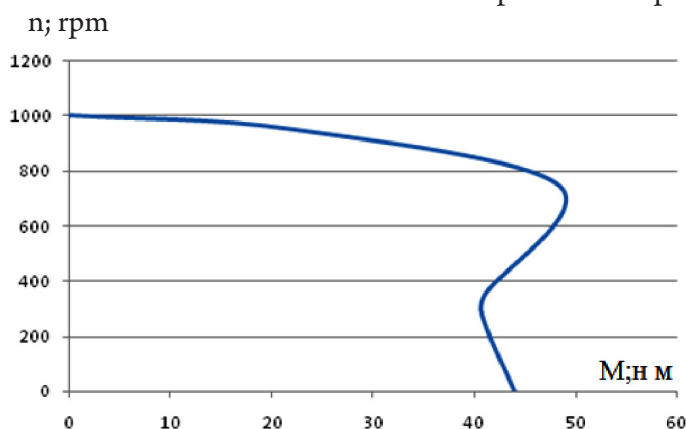

Figure 2. The mechanical characteristic of the induction motor with a squirrel-cage rotor of the type 4A100L6Y3

According to figure 2, it is defined that the nominal torque of the induction motor is $M_n = 22 \text{ H} \cdot \text{m}$, the start-

ing torque $M_{н.т} = 44 \text{ H} \cdot \text{m}$, and the critical moment is $M_{kp} = 44 \text{ H} \cdot \text{m}$ $M_{kp} = 48,4 \text{ H} \cdot \text{m}$.

References:

1. Salimov J. S., Pirmatov N. B. Elektr mashinalari. – T.: O'FMJN, – 2011. – 408 b.
2. Berdiyev U. T., Pirmatov N. B. Elektromexanika. – T.: Shams ASA, – 2014. – 391 b.

*Rustamov Sherzod Rustamovich,
assistant, at the department
"Using water energy and pumping stations",
Tashkent institute of irrigation and agricultural
mechanization engineers (TIAME), Uzbekistan
E-mail: ikramov-1978@mail.ru*

*Nasirova Naira Ravilevna,
Junior resercher,
Tashkent institute of irrigation and agricultural
mechanization engineers (TIAME), Uzbekistan
E-mail: n_naira1982@mail.ru*

CONSTRUCTIVE PECULIARITIES OF MODERNIZED CENTRIFUGAL PUMP

Abstract: Theoretical basis for calculating the new design of a centrifugal pump. The article describes the design and design efficiency factor of the new pump on the geometric dimensions of the working part and is compared with the real value. When testing the model, a high efficiency factor of the new pump was fixed 80.7 ... 86.4%.

Keywords: centrifugal pump, operating characteristics, cavitation and abrasive wear.

In the Republic there were problems with the operation of systems with mobile and stationary means of water lifting. By 2015, the capacity of the main pumping and energy equipment, spent park (factory) resource, was more than 70% of the installed capacity at large pumping stations (PS). In the context of urgent renovation, an operational strategy must be defined, aimed at maintaining the necessary reliability and economic parameters of their basic elements. The definition of «limiting» elements of the main equipment in the changed operating conditions is an extremely urgent task at the beginning of the XXI st century [1].

More than half of accidents and failures are caused by physical wear of the impeller units (IU), chamber IU, bearings, i.e. the main nodes, the restoration of which requires complete disassembly with the withdrawal of them from operation for a long period. The average weighted efficiency is reduced, the operating characteristics deteriorate, the supply and pressure of the pumps is reduced.

The volumes of reverse water leakage (flow from the pressure part to the suction through the design gaps, valves, etc.) are increasing. For a comparative evaluation of these leaks, the concept of a volumetric efficiency

$$\eta = Q / Q_T,$$

where Q is a real feed; Q_T is the theoretical feed.

The concepts of theoretical useful power

$$N_T = 0,001\rho gQ_T H_T$$

and mechanical efficiency of the pump

$$\eta_M = N_T / N$$

These parameters completely characterize the individual elements in terms of their functionality and dependency with other pump units. The main disadvantages of the previously created pumps are:

- Large mechanical wear of the body parts of the sealing elements, friction pairs;
- Erosion, cavitation and abrasive wear of the IU and hulls;
- Application of low-grade, low-quality sealing gaskets.

When designing modern centrifugal pumps, it is possible to complicate their designs. For example, the European centrifugal pump contains a casing with an engine and suction nozzle and a device for twisting the flow at the inlet to the IU [1, 2]. The disadvantage of such pumps is that not all of the peripheral flow is curled, which creates reverse vortex zones. The authors created a number of new centrifugal pumps with high demands on cavitation qualities [3].

In order to increase the uniformity of the twist of the flow along the periphery in one design, the channel is annular and the chamber has an area of flow that decreases in the direction in which the flow of water flows therein. In (Fig. 1) shows a longitudinal section of the pump.

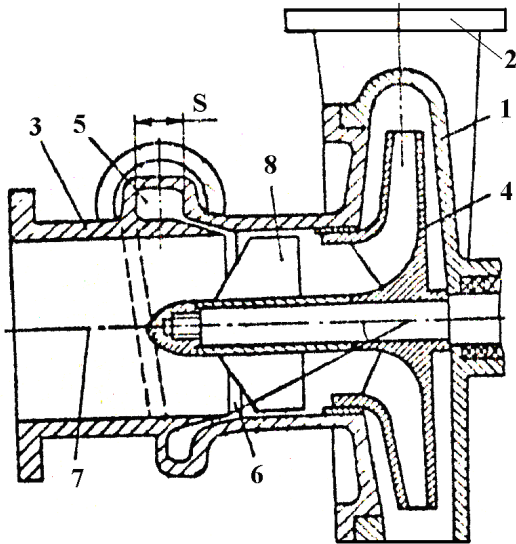

Figure 1. Centrifugal pump with pressure and suction nozzles

The centrifugal pump comprises a body 1 with a delivery and suction nozzles 2 and 3, a device for swirling the flow at the wheel 4 in the form of a chamber 5 connected to a delivery nozzle 2 surrounding the suction pipe 3 and a channel 6 located at an acute angle to the pump axis 7 and oriented to the IU4, the duct 6 being annular and the chamber 5 having a cross-sectional area S decreasing in the direction of movement of the water flow therein.

When the pump is running at partial feeds, water flowing through channel 6 twists the peripheral flow region at the inlet of the wing 8. This is achieved by varying the supply of a constant flow angle on the wing blade 8, which ensures the absence of cavitation damages.

The efficiency of the working process of the new pump is determined

$$\eta = \frac{Q}{S\omega_k}, \quad (1)$$

where Q – water flow in the side channel (pump feed);

S – static moment of the lateral channel area relative to the IU axis;

ω_k – is the angular velocity of the IU.

Calculating the efficiency of new pumps according to the geometric characteristics of the working elements and compar-

ing them with actual values show that the actual efficiency is less by 3–10% calculated by formula (1). Thus, according to formula (1), the maximum achievable (theoretical) value of the efficiency of the new pump is determined [2].

If we represent the motion of water in a lateral channel with a circumferential velocity ω_l as a rotation with respect to the axis of the pump with angular velocity ω , i.e. $u = \omega r$, where r – is the radius of the center of gravity of the side channel area, we obtain $Q = Fu$ and $S = Fr$, which coincides with the hydraulic efficiency.

The pressure increase in the side channel of the new pump is determined only by the energy losses in the water stream. This conclusion is now used in the construction of models and design schemes for a new pump with holes in the plates (Figure 2).

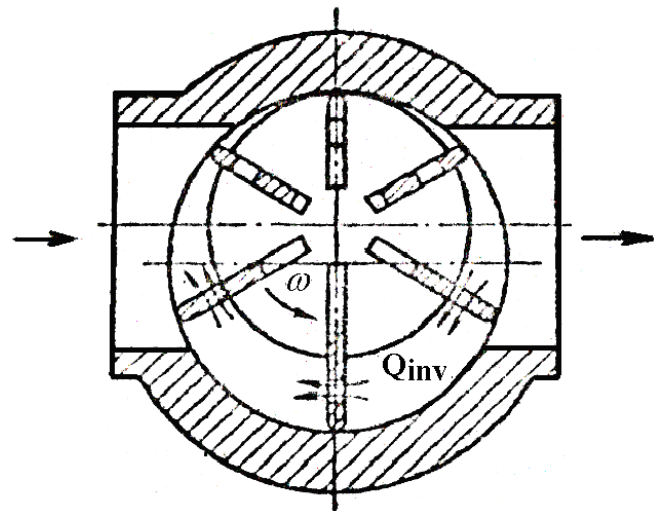

Figure 2. Diagram of the modernized pump with holes in the plates

In a real pump, due to the increase in leakage over the plates, the actual efficiency is less than the volume efficiency: $\eta \leq \eta_v$, i.e. $\eta = \eta_v$.

We construct the characteristics of a pump with holes in the plates. We use the following notation: Q – supply of the ideal pump (without holes in the plates): $Q = Q_{network} + Q_{inverse}$ ($Q_{network}$ – supply to the network, $Q_{inverse}$ – leakage through the holes.) When the pump is operated on the open discharge pipe (head is zero), the pump $Q_{network}$ slightly lower than Q , due to the presence of holes in the plates. The pump head will equal the sum of the hydraulic losses in the backflow:

$$H = \frac{P_2 - P_1}{\gamma} = \sum h_T, \quad (2)$$

where P_1, P_2 - pressure in the suction and discharge nozzles; Σh - hydraulic losses in the return flow on the holes in the plates.

The leakage value is defined as

$$Q_{\text{офп}} = \mu f \sqrt{2gH}, \quad (3)$$

where f - is the area of the hole; μ - equivalent flow coefficient; H - pump head.

Tests of the new pump were carried out on the test stand IS-1, in accordance with the method of periodic tests based on ISO 9906: 1999.

The characteristics of the pump D2000-21 were taken in the feed interval from 0 to the maximum flow, with

a submerged pump IU of 2.0 m, excluding cavitation, in accordance with TSh 46.31-16: 2002.

Conclusions:

1. Performance characteristics of the new pump with impeller diameter $D_{iu} = 425$ mm showed the value of efficiency $\eta\%$ calculated 80.1 ... 83.0, actual 80.7 ... 86.4, deviation + 3.4 ... + 0.6. During the tests, vibration and noise were not observed. The working range of water supply at the rotor speed $n = 985 \text{ min}^{-1}$ is from 1188 m^3/h to 2125 m^3/h .

2. These characteristics show the need to apply the designs of new advanced parameter pumps for the modernization of irrigation pumping stations.

References:

1. Dzhurabekov A., Rustamov Sh., Glovatsky O. Mechanism of cavitation and hydroabrasive wear of centrifugal pumps of irrigation pumping stations // Collected papers, SIC ICWC of Central Asia, - Tashkent, - 2017. - P. 153-159.
2. Glovatsky O., Ergashev R., Rustamov S.H. Improvement to usages and studies large pumping station // Monograph. LAP LAMBERT Academic Publishing. - Saarbruken. - 2013. - 170 p.
3. Glovatsky O., Nasyrova N., Saparov A. New methods of weakening cavitation modes during operation of pumping equipment of the pump station «Bek-Yab» // Bulletin of the Karakalpak Branch of the Academy of Sciences of Uzbekistan, Nukus, - 2016. - P. 28-32 p.

Tillaev Mamjabbor D. S.,

C.T.S., Professor,

Yunusov Saloxiddin Zunnunovich,
docent,

Axmedov Mirzokir Xakimovich,
assistant, Tashkent Institute of Textile and Light
Industry, city. Tashkent. Uzbekistan

E-mail:

EFFECT OF AIR FLOW ON THE YIELD OF FIBER AND SEEDS FROM THE WORKING CHAMBER OF GIN

Abstract: In the article from the point of view of science, the question of working chain saws and fibers on the bar instead of a meeting was considered. The obtained mathematical models with the help of the fiber particles of the working organs are found and the containment condition is determined, and also the article studies the finding of gin-seed at the working end of the gin. Determined under the influence of what and with the help of what forces return the seeds back to the working chamber. In addition, the study of the presence of seeds in the intercity space and the way out of it has been studied.

Keywords: Strain fiber, gin, sawing cylinder, elastic forces, working chamber, fiber bundle, teeth saw.

The fiber is removed from the main saw cylinder by means of an air flow. O_2 and R_2 are the center and radius of the main saw cylinder respectively, and O_1 and R_1 are the center and radius of the auxiliary (removable) dusty cylinder; A – a current of a meeting of a periferinic layer of an air stream, circulating around an auxiliary saw cylinder, with the basic saw cylinder. The position of point A depends on the constructive solution.

The origin is placed at point A , and the X axis is directed along the front edge of the tooth. Two cases of movement of the fiber bundle relative to the front face of the saw tooth are possible: in the first fiber moves along the front face of the tooth; in the second, the fiber moves without contact with the front face of the tooth. In the first case it takes the form

$$\left. \begin{aligned} m\ddot{X} &= S \cos \alpha + T \cos \varphi - F \\ m\ddot{Y} &= S \sin \alpha + T \sin \varphi + N - P_k \end{aligned} \right\} \quad (1)$$

Taking into account that, $F = \mu N$ where μ – the coefficient of friction, P_k = the system of equation [1] can be replaced by one equation.

$$m\ddot{X} = S(\cos \alpha - \mu \sin \alpha) + T(\cos \psi - \sin \psi) - \mu P_k \quad (2)$$

$$\text{Where } S = \frac{m v^2}{R_1}; \quad T = c \mu \rho [v_s - v_s \sin(\alpha + \psi)]^2;$$

$$P_k = 2m \frac{v_1}{R_1} X.$$

where S – is the centrifugal force; T – is the tangential force; F – is the friction force; N is the normal reaction.

On condition

$$N = S \sin \alpha - T \sin \varphi + P_k > 0$$

or

$$T < \frac{S \sin \alpha + P_k}{\sin \varphi} \quad (3)$$

there is a separation of the beam from the saw's tooth.

If $N = 0$

$$T = \frac{S \sin \alpha + P_k}{\sin \psi},$$

then the equation of motion of the fiber bundle takes the form

$$\ddot{X} = A_1 + B_1 X, \quad (4)$$

Where

$$A_1 = \frac{v_1^2 \cos \alpha (\sin \psi + \sin \alpha)}{R_1 \sin \psi}; \quad B_1 = \frac{2 v_1 \cos \alpha}{R_1 \sin \psi};$$

If the contact motion of the fiber bundle during its removal from the saw tooth is absent, then the equation of motion can be represented in the form

$$\left. \begin{aligned} m\ddot{X} &= S\cos\alpha + T\cos\psi \\ m\ddot{Y} &= -S\sin\alpha + T\sin\psi \end{aligned} \right\} \quad (5)$$

The solution of the equation is the function

$$X = \frac{A+B}{D^2}(Dt + e^{-Dt} - 1), \quad (6)$$

Where

$$A = \frac{V_1^2}{R_1}(\cos\alpha - \mu\sin\alpha),$$

$$B = \frac{c\mu[V_{\sigma} - V_{\sigma 1}\sin(\alpha + \psi)]^2(\cos\psi + \mu\sin\psi)}{m} = \frac{T(\cos\psi + \mu\sin\psi)}{m},$$

$$V_{\sigma} = \sqrt{V_{B1}^2 + V_{B2}^2 + 2V_{B1}V_{B2}\cos(0 - \xi)},$$

$$\psi = \arctg \frac{V_{B1}\cos\alpha + V_{B2}\cos(\alpha - 0 - \xi)}{V_{B1}\sin\alpha + V_{B2}\sin(\alpha - 0 - \xi)}.$$

Expression (6) is the equation of motion of the fiber bundle during its removal from the saw teeth under condition

$$T < \frac{S\sin\alpha + P_k}{\sin\psi} \quad (7)$$

In the case of a beam of fiber in contact with the saw's teeth, we obtain a solution to the problem posed, taking into account the initial conditions in the form

$$X = \frac{A_1}{B_1^2}(e^{B_1 t} - B_1 t - I), \quad (8)$$

Where

$$A_1 = \frac{V_1^2 \cos\alpha(\sin\psi + \sin\alpha)}{R_1 \sin\psi}; \quad B_1 = \frac{2V_1 \cos\alpha}{R_1 \sin\psi};$$

$$\psi = \arctg \frac{V_{B1}\cos\alpha + V_{B2}\cos(\alpha - 0 - \xi)}{V_{B1}\sin\alpha + V_{B2}\sin(\alpha - 0 - \xi)}.$$

We now turn to the case when

$$T > \frac{S\sin\alpha + P_k}{\sin\psi},$$

When the fiber bundle, when it is being removed, does not move along the front face. In this case, the system is a system

$$\begin{aligned} X &= (S\cos\alpha + T\cos\psi) \frac{t^2}{2m}, \\ Y &= (T\sin\psi - S\sin\alpha) \frac{t^2}{2m} \end{aligned} \quad (9)$$

An important factor in determining the results of ginning is the efficiency of seed removal from the working chamber. The process of denuding seeds occurs by repeatedly exposing the teeth of the saws to the fly, i.e., by multiple gripping and tearing of the fiber by the saw tooth.

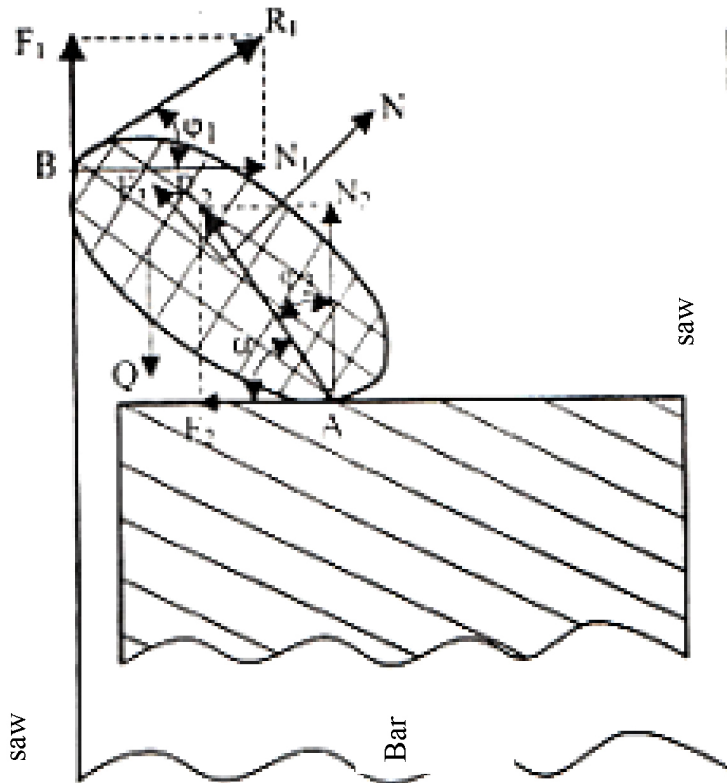

Figure 1. The scheme for determining the movement of seeds in the inter-spiral space

Theoretically, the bare seeds must roll down the nullo part of the grate to the seed comb, but in the real process the seeds are entrained in a dense raw roller and remain in its mass for a long time, since it is known that the seeds after exposure are stored in the working chamber for a considerable time. Also, it is known that the seeds released to the surface of the grate are once again carried on the saws in a raw roller.

The most profound research on the allocation of seeds was carried out by D. A. Kotov and G. I. Boldinsky [1]. They established that single seeds falling on the surface of the grate can not be brought by the lateral planes of the saws into the raw gin roller.

Assume that, with the existing parameters of the sawed gin, the individual seeds, regardless of the degree of their descent, will fall between the saws on the grate surface [2]. Then, even with the angle of incline of the bars, equal to zero, it is impossible for them to move upward (Fig. 1), carried out by friction forces of the lateral planes of the saws.

To determine the magnitude of the normal reaction N_1 and N_2 the following formulas are introduced:

$$N_1 = \frac{Q \operatorname{tg} \varphi_1}{1 + \operatorname{tg} \varphi_1 \operatorname{tg} \varphi_2}; \quad N_2 = \frac{Q}{1 + \operatorname{tg} \varphi_1 \operatorname{tg} \varphi_2}$$

Where Q is the force of gravity, H;
 φ_1, φ_2 the angles of deviations of reactions N_1 and N_2 depending on the forces R_1 and R_2 ;

The driving force is determined from equality

$$F_1 = Q - N_2 = \frac{Q \operatorname{tg} \varphi_1 \operatorname{tg} \varphi_2}{1 + \operatorname{tg} \varphi_1 \operatorname{tg} \varphi_2};$$

If a group of seeds wedges between the saws is not free, but under the action of the centrifugal and elastic forces that arise when the raw roller rotates, then the forces named will be defined as:

$$F_1 = Q \cos \alpha + F_2 + \frac{mV^2}{r};$$

where F_1 – is the constituent force acting on the seed group in the direction of the radius. α – corner formed by a directed force and radius, rad; F_2 is the elastic force of the roller, H;

m – mass of the seed group, kg;

V – velocity of the seed, m/s;

The frictional forces that prevent the movement of a group of seeds will be equal to the magnitude

$$F_3 = KN;$$

where K – is the friction coefficient of the fiber against steel;

N – is the normal force with which a group of seeds presses on the sides of the saws, H;

In conclusion, we note that if $F_3 < F_1$, then a group of seeds can jam between the saws, i.e. to hang between them, and certainly will be returned to the raw roller in the area where the teeth will drift off the grate.

References:

1. Kotov D. A., Boldinsky G. I. "On the allocation of seeds from a raw bead of sawed gin" Sb.NIR TTI. – Tashkent TTI – 1964. – No. 18.
2. Jabbarov G. D., etc. "Primary processing of cotton" Textbook, – Moscow. Easy Industry, – 1978.

*Toshtemirov Sanjar Jumaniyazovich,
Karshi Engineering-Economics Institute,
associate professor, (Republic of Uzbekistan)*

*Mamatov Farmon Murtozevich,
Karshi Engineering-Economics Institute,
professor, Head of the Department of scientific-applied
researches and Innovation (Republic of Uzbekistan),
E-mail: fmamatov50@mail.ru*

*Batirov Zafar Lutfullayevich,
Karshi Engineering-Economic Institute,
candidate, of technical sciences, Vice-rector
Republic of Uzbekistan*

*Chuyanov Dustmurod Shodmonovich,
Karshi Engineering-Economics Institute,
candidate, of technical sciences, associate –professor,
Republic of Uzbekistan*

*Ergashov G'ayrat Khudoyorovich,
assistant, Karshi Engineering-Economics
Institute, (Republic of Uzbekistan)*

*Badalov Sunnat Mamadiyevich,
Karshi Engineering-Economics
Institute, assistant, (Republic of Uzbekistan)*

ENERGY-RESOURCE-SAVING TECHNOLOGIES AND MACHINE FOR PREPARING SOIL FOR SOWING

Abstract: Technologies of processing and preparation of soil for sowing of agricultural crops, carried out by a multifunctional machine, are presented.

Keywords: technology, soil cultivation, frontal plow, multifunction machine, productivity, smooth plowing.

Introduction. In the Republic of Uzbekistan, various sets of equipment are used to process and prepare soil for sowing agricultural crops, which leads to a significant expansion of the fleet of agricultural machines in farms and machine-tractor parks. At the same time, the utilization rate of existing tillers is low, which significantly affects the cost of agricultural products. One of the main reasons for the low coefficient of using tillage machines are methods of processing and preparing the soil for sowing. Currently, the preparation of soil for sowing and sowing of crops is carried out by traditional technologies, i.e. Single-operation machines for several

passes. Traditional technologies are agronomically and economically unjustified, as labor productivity decreases, labor and funds are expended, soil is compacted, soil preparation time is tightened, soil is intensively dried, which leads to a decrease in crop yields. One of the ways to solve this problem is the use of multifunction machines.

Objects and methods of research. The object of research is the technology of preparing soil for sowing crops and a multifunctional machine. The methods of system analysis and the rules of agricultural mechanics were used in the research.

Results of the research. The Karshi engineering economics institute has developed a multifunctional machine based on a combined front plow. It is known that front plows are different from traditional plows of small, independent of the width of capture length, a symmetric compact balanced design and low material capacity [1, 6–8; 2, 28–29; 3, 35–37].

A feature of the multifunctional machine is the installation on the load-bearing system of the machine of replaceable working elements that ensure the processes of both basic and surface tillage, and the preparation of soil for sowing different crops using new technologies.

Multifunctional machine provides the following technologies:

– smooth, beardless plowing with a turnover of layers at 180° within its own furrow. To implement this technology, the machine is equipped with front – mounted right – and left – handed plow cases 1 and 2 and chucks 3, which turn the seams within its own furrow by 180° , and also with a support loosening roller 4 (fig. 1a) [1, 6–8; 2, 28–29];

– non-waste processing with strip subsoiling loosening of soil exposed to wind and water erosion. At the same time, the unit is equipped with non – discarded right- and left – shifting bodies 5 and 6, deep loosers 7 and leveling – packing unit 4 (fig. 1b) [4, 86–88];

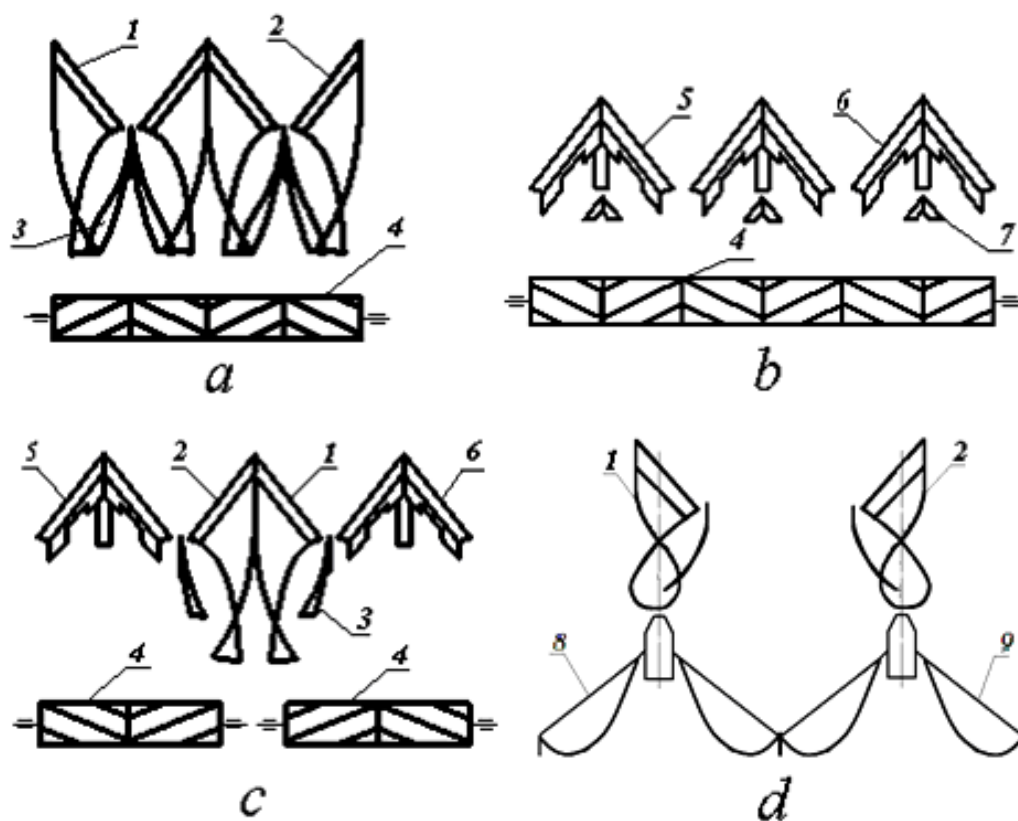

Figure 1. Scheme of multifunction machine

– preparation of soil for sowing of vegetables and other crops. To implement this technology, the machine is equipped with symmetrically located right – and left – shifting bodies 1 and 2, short runners 3, rippers for small machining, installed on the sides of housings 1 and 2, with crusher 4 (fig. 1c) and a device for applying fertilizers. Rippers 5 and 6 can be made in the form of bezotvalnyh cases [5, 27; 6, 12; 7, 125–126; 8, 234–236];

– preparation of soil for sowing cotton on the ridges with simultaneous application of fertilizers. To implement this technology, the machine (Fig. 1d) is equipped with the right – and left – shifting bodies 1 and 2, with dump plows of the 9 type “paraplau” and a device for applying fertilizers. At the same time the formation of new ridges is performed instead of existing ridges [9, 11].

In 2014–2017 years in Kashkadarya region of Uzbekistan, economic tests of a multifunctional machine with interchangeable working bodies were carried out. The machine showed a high-quality and reliable work in the dumping of soil from under the wheat, the preparation of soil from under cotton to the ridge planting with

simultaneous local fertilization, dump and soilless tillage of slopes and preparation of soil for sowing melons.

Conclusion. The tests showed that the use of a multifunctional machine can reduce labor costs by 25 ... 28%, fuel – 21 ... 25% and operating costs – 30 ... 35% compared to existing machines.

References:

1. Маматов Ф. М., Эргашев И. Т., Равшанов Х. А., Исломов С. И. Обоснование параметров механизма навески плуга на трактор // Механизация и электрификация сельского хозяйства. – Москва, – 2000. – № 11. – С. 6–8.
2. Маматов Ф. М., Эргашев И. Т., Исломов С. И. Комбинированный фронтальный плуг с активными рабочими органами // Механизация и электрификация сельского хозяйства. – Москва, – 2001. – № 8. – С. 28–29.
3. Лобачевский Я. П., Маматов Ф. М., Эргашев И. Т. Фронтальный плуг для хлопководства // Хлопок. – Москва, – 1991. – № 6. – С. 35–37.
4. Маматов Ф. М., Мирзаев Б. С., Авазов И. Ж. Агротехнические основы создания противоэрозионных влагосберегающих технических средств обработки почвы в условиях Узбекистана // Природообустройство. – Москва, – 2014. – № 4. – С. 86–88.
5. Маматов Ф. М., Мирзаев Б. С., Чуянов Д. Ш., Эргашев Г. Х. Агрегат для новой технология подготовки почвы под бахчевые культуры // Картофель и овощи. – Москва, – 2011. – № 1. – 27 с.
6. Маматов Ф. М., Мирзаев Б. С., Чуянов Д. Ш., Эргашев Г. Х. // Агрегат для предпосевной подготовки почвы // Сельский механизатор. – Москва, – 2011. – № 7. – 12 с.
7. Mamatov F. M., Kodirov U. I. Energy-resource machine for preparing soil for planting root crops on ridges // European Science Review. – Vienna, – 2016. – No. 11–12. – P. 125–126.
8. Mamatov F. M., Shodmonov G. D., Chuyanov D. Sh., Ergashov G' Kh. New technology and combined machine for preparing soil for sowing gourds // European Science Review. – Vienna, – 2018. – No. 1–2. – P. 234–236.
9. Маматов Ф. М., Мирзаев Б. С., Рашанов Х. А., Темирова Д. И., Ахматов Б. Р., Авазов И. Ж., Кодиров У. И., Тоштемиров С. Ж. Комбинированное почвообрабатывающее орудие // Патент на полезную модель UZ FAP 00672. Официальный бюллетень. – Ташкент, – 2011. – № 12. – 11 р.

*Shayumova Zamira Mustafayevna,
the basic doctoral student,
Scientific and Technical Center, Uzbekistan, Tashkent
E-mail: zamira88@list.ru*

APPLICATIONS OF A CONTROLLED ELECTRIC DRIVE WITH REACTIVE POWER COMPENSATION

Abstract: The article gives the possibility of using a regulated electric drive with reactive power compensation. At the same time, the advantage of using frequency converters is analyzed, which allows saving energy, which is actual for today. Methods for improving the shape of the input current or for compensating the reactive power are given. These theoretical concepts are justified by a description of the graph of the dependence of the efficiency of an induction motor 4AI160S4 on the load.

Keywords: frequency converters, power, harmonics, motor, compensation, regulation, frequency.

In power supply networks with an electric load, they have transients that can change the supply voltage. Due to the increase in the capacity of the induction motor used in the wires and the increase in the price of electricity, the problem of reactive power compensation is the main reason for the operation of power supply systems. As the control and increase of accuracy and achievement of power indicators, AC electric drives with frequency, frequency-current and vector control are competitive in accuracy, speed and control ranges with respect to DC electric drives.

Every year, the installed power of frequency converters (inverters) in enterprises is increasing, because in addition to automation of production processes, they save energy, which is very important for today. The frequency control method provides:

- smooth control of engine speed in a wide range on both sides of the nominal;
- rigid artificial characteristics;
- constant overload capacity.

If the installed power of the drive is no more than 10% of the power of the transformer input, then there are no special issues. If the total installed power of the frequency converters will be more than 20–30%, then there will necessarily arise questions related to the operation of frequency converters. Compensation for reactive power will become difficult due to overheating of the capacitors of the compensating plants [1]. It is possible to alter the compensating units by installing in series with the capacitors the suppressing chokes, but as a result, the

input transformer is heated. Saving energy will decrease. Frequency converters with a direct current link, namely such frequency converters in the overwhelming majority used in a frequency-controlled electric drive, consume a current from the network, the shape of which is far from being sinusoidal. As a result, in the input network there are odd and not multiple three higher harmonics – these are 5, 7, 11, 13, 17, etc. It is the higher harmonics that create problems for us [2].

Recently, to improve the shape of the input current or compensation of reactive power, active filters are used that are connected in parallel to the mains. The functionality of active filters is much more passive. For example, in the active filter, you can program one or more harmonics to be suppressed, you can work in compensation mode. Active filters are simply necessary for those enterprises in which all methods of suppressing the higher harmonics do not give the expected result. The share of the electric drive accounts for about 70% of all generated electricity. Therefore, the efficiency of using this electricity is of great technical and economic importance. Power to the electric drives comes from the industrial AC network frequency of 50 Hz. Electric drives consume active power from the network.

Active power is expended on useful work and covering losses in the entire electromechanical system of the working machine. Analyzing the efficiency of the use of electrical energy, it is necessary to distinguish between the energy efficiency of the process itself, which is carried out by a working machine with an electric drive,

and the efficiency of the actual drive, characterized by its efficiency, which is the ratio of the output power P_{inp} of this device to the input power P_{use} , (or energy) to the spent P sash:

$$\eta = \frac{P_{out}}{P_{inp}} = \frac{P_{use}}{P_{spent}} = \frac{P_{use}}{P_{use} + \Delta P} \quad (1)$$

where ΔP is the loss in this device, $\Delta P = \frac{P_{use}(1-\eta)}{\eta}$

Since the power part of the electric drive consists of an electric motor, a transmission and a converter device, the efficiency of the electric drive:

$$\eta = \eta_{eng} \eta_{tran} \eta_{conv}$$

where $\eta_{eng} \eta_{tran} \eta_{conv}$ – Efficiency of the engine, transmission and conversion devices, respectively. The efficiency of the converter device, made on the basis of power semiconductor devices, is quite large. The losses in the converter are mainly determined by the direct voltage drop in the semiconductor device. On average, we can assume that $U = 2V$, for bridge circuits $U = 4.0V$.

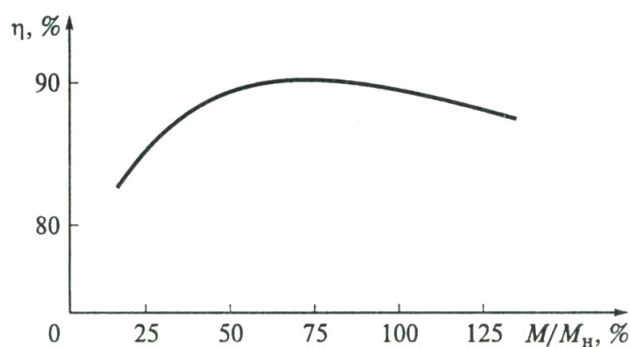

Figure 1. Dependence of the efficiency of an induction motor 4AI160S4 on the load

Thus, the nominal losses for 440 V converters are 1%, and for converters with a voltage of 220V – 2%. Taking into account losses in the reactive elements of semiconductor converters, their efficiency can be taken equal to 0.95 ... 0.98. Losses in mechanical transmission devices (reducer, transmission, etc.) are determined mainly by frictional forces [3]. These losses, and consequently, the efficiency of mechanical transmission depend on the type of bearings used, the class of gears, lubrication systems, etc. The efficiency of a mechanical transmission depends essentially on the moment being transmitted. Under the efficiency of a working machine (PM) is understood the product of the efficiency of an electric drive at the efficiency of a working machine.

In the alternating current network, from which power is supplied to the electric drive, the reactive power circulates, as a result of which the network is supplied with a reactive current that does not generate work. The reactive power is estimated by $\cos\varphi$, where the angle φ is the phase of the shift of the first harmonic of the cur-

rent with respect to the first harmonic of the voltage. In asynchronous short-circuited motors, the nominal $\cos\varphi = 0.7 \dots 0.8$. The underload of the induction motor leads to a further decrease in $\cos\varphi$. In drives according to the TP-D system, $\cos\varphi = \cos a$, which is determined by the delay set by the pulse-phase control system, the opening of the thyristors. Therefore, in the TA -D drives at high speed, $\cos\varphi$ in the AC power supply will be high (0.8 ... 0.9), as the speed decreases, when the angle a increases, $\cos\varphi$ will decrease [4]. When the TP-D drive is turned on, “reactive power” throws occur.

In modern systems of a regulated electric drive, uncontrolled rectifiers tend to use the regulation of the voltage applied to the motor windings by pulse-width methods. In this case, the $\cos\varphi$ in the mains will be at least 0.95. In terms of reactive power compensation for many electricity consumers, it is effective to use high-power synchronous motors for unregulated electric drives, which, when overexcited, can generate reactive power to compensate for it in the power system of the enterprise.

References:

1. Rozanov Yu. K. "Fundamentals of power electronics." – M. Energoatomizdat, – 1992.
2. Zhezhelenko I. V. "Higher harmonics in power supply systems of industrial enterprises". – M. Energoatomizdat – 1984.
3. Control methods used in frequency converters for controlling AC motors. (Electronic resource) URL: <http://dataural.ru/stati>.
4. Leznov B. S. Energy saving and adjustable drive in pumping and blowing plants. – M.: Energoatomizdat, – 2006. – 360 p.

Section 12. Physics

*Barykinsky Gennady Mikhailovich,
Institute of conceptual studies,
Moscow, Russia
E-mail: k@genn.ru*

THE UNIVERSE BEFORE, IN THE PROCESS, AND AFTER THE BIG BANG. PART I. THE PROJECT CREATOR

Abstract: in this work, on the basis of non-standard reception and the method of analytical logic of constructing concepts, the resulting definition of the concept of the Universe, the physical and philosophical substantiation of the fundamental properties of the universe determining the very fact of Its existence is also proposed.

Keywords: universe, concepts, definitions, structure, things, virtuality, principles, laws.

We acquire knowledge
by learning the essence of things
And realizing the meaning of things
We create consciousness [1].

The Creator is the Limit of the Evolution of the Universe

Once, when there were no more people, earth, sun, numerous stars, and almost the entire Universe, the Creator, unexpectedly for himself, was discouraged and plunged into deep reflections about his “life-being”, and in general about the great mission of his existence. He was tired of wallowing in the perception of his omnipotence. He stood on the threshold of his maturity and more and more often thought about his mission and the underlying goal-setting.

For some time now, he began to notice that in him, in his mind, there was a wormhole, which endlessly undermined mental balance and comfort. However, something in the mind prompted that everything is not so simple here that a moment has come when a frivolous attitude towards a sense of conscience can ruin not only him, but, frankly, problems of a cosmic scale may arise. The recurrences of the awakening of conscience have repeatedly arisen before, but they have always been perceived by him as something new and unnecessary, while the memory of these moments, throughout his unprecedented life, has always been erased as unnecessary.

It so happened, but as he ascended the Olympus of his omnipotence, he had less and less to turn to simple, conditionally speaking, human values, most of which for him lost any meaning whatsoever. He has long resigned himself to the fact that his so-called “life-being” does not quite resemble the life of a common man from the civilization of people. His existence sometimes seemed to him as something abstract and irresponsible. And he liked it. After all, he has been alone for many billions of years. He has no one with whom he could communicate, argue, create and perform.

Since there was no civilization of people, he fully realized the great meaning of everything, including himself. This did not happen immediately. He has long learned that awareness is not a fast process, especially when this process is about extremely complex topics. The main of which is himself. Once he felt a moral relief from the fact that in the mind there was some clarity in understanding the great essence of what was happening. For a long time people have been trying unequivocally to solve for themselves a seemingly simple question: what is primarily in the nature, matter or consciousness? They did not

succeed yet, however much they argued. And only after many millennia, the Creator realized that in fact the question of primacy does not exist, on the contrary – there is a great harmony, the meaning of which is that one of these two fundamental phenomena exists for the sake of the existence of another.

More precise words, in consciousness, as a result of human evolution and the process of conformal mapping of phenomena occurring in the Universe underlying it, an almost infinite-dimensional Picture of the world (this process resembles the game in “Fold puzzles”) is formed. The limit of these processes is the very fact of the emergence of the Creator, which in turn has a significant impact on the process of the birth and evolution of the new Universe.

The time has come for the lack of civilization of people, and, accordingly, the absence of social and humanitarian spheres that are the basis of the existence of their social relations. There came a time when he was forced to concentrate on the knowledge of the mechanisms and forms of the movement of an almost infinite variety of things that form a great symbiosis of the universe and consciousness, or, in other words, the symbiosis of the Universe of consciousness and the picture of the world [1]. In the end, his intellect was literally grounded on the nature of things and the prospect of making difficult decisions related to the fulfillment of the prescriptions determining the very fact of its existence.

In the meantime, for now, as a young man, he liked, especially without straining, just to exist. He was quite satisfied with the state in which he is. Unlike the previous environment, he was most entertained by the ugly side of the great variety of everything. He got tired of the past with his highly organized cosmological system, in which he originated himself, and along with it (in the process of evolution) he accepted the state that most suited him, though not for long. For some time now, he increasingly indulged in the “game” in his omnipotence, he “experimented” a lot and watched with curiosity how “barren” universes and black holes, “crazy” galaxies, “warped, huge and unwieldy” stars, “unbridled” the burrows of the dying stars “struggle” for their existence, but in the end everything disappears, turning into nothing in the fire of giant cosmic explosions, exotic catastrophes and fantastic phase transitions of matter between the universes.

Despite everything, he always, with special gratitude, realized that the main inheritance that he received from

people is a great sense of naturalist. Depressed only one thing, this is the absence of those with whom he could discuss the results of his pleasures and creations, and therefore there were none with whom he could share his successes, results and observations. The most horrible thing that sometimes led him out of the state of equilibrium is the lack of any need and necessity for them to at least somehow take advantage of himself, since almost all the predictions to him have become known for quite some time.

However, it all starts someday and it all eventually ends. And now the moment has come for the adoption of decisions, which in their importance are commensurate with such concepts as conscience and the great mission of its existence. Realizing the inevitability of the future, he again thought deeply, in memory, one after another the events of his infinite, by human standards, life began to arise. He has long ceased to measure time and space, the essence and meaning of which for him generally lost all significance, as his own date and place of birth.

All this happened quite a long time, namely at the turn of the disappearance of those who were doomed to painstakingly measure time and space, trying to extrapolate as much as possible the course of events. People certainly wanted to predict their future as far as possible, but this did not help them, because all this contradicted the meaning of the existence of their species. But he does not have such a problem. He knows, very well, not only his past, not to mention the present, but his whole future. He has long learned the simple truth: who measures time, he simply lives, but not for long, but all the others exist. But all the rest of it is he, since all the rest of the rest are not commensurable with him.

However, from time to time, gradually, under the influence of his relatively new feelings, he began to feel that his whole existence, in the categories of people, looks immoral to put it mildly. In the soul there was growing shame, because he abused the meanings of his existence. Something cracked inside him. The sense of guilt was crystallized more intensely because he thought lightly of the great mission of his predestination. His consciousness began to suppress the abyss of memories of all the innumerable sacrifices and costs that were placed on the altar of his (ie His) creation. He felt ashamed of everything that provided his mission – the mission of the Creator. There was a time when he fully realized this duty, but his performance was constantly postponed to later

times, continuing to enjoy his omnipotence. After all, in youth it was so tempting and so alluring!

He always wanted to be eternal, emotions overwhelmed. However, more and more often there were moments when from the depths of his consciousness, a feeling of modesty and understanding that not everything in his Creator of power grew. He understood that his “infinite” existence is not at all infinite, and that his resources are limited, especially in the most important degrees of freedom. Even with his genetic principle, which is the bearer of his sense of conscience, he is unable to agree. He always knew that this very conscience depends not so much on his own will and consciousness as on genetic heredity, which it is also difficult to change, as it is impossible to organize a journey into the past. However, it never embarrassed him, because in a mental immersion he could always travel anywhere and ad lib. Here and now he remembered the dramatic events from the life of people of the past, events that have a fundamental relation to the concepts of conscience and the meaning of life.

At the same time, he remembered that people once wrote a lot of scriptures, the so-called bibles, giving them for the teachings about him – about the Creator, but in fact, these books were not about him, not about the Creator, but more about Conscience and the complexities of a fundamental life. They, these books, for many millennia led people through the unknown roads of knowledge and understanding, constantly proving that conscience, this is without which there can not exist a high intellect of a reasonable person. Moreover, already at the earliest stage of the development of human civilization, it was the intellect of individual specially developed individuals that correctly predicted the very fact that not everything was in its Creator of power. Against the backdrop of insignificant ideas about the nature of the universe, these specially developed people in one of the books have perspicuously put in the mouth of the Creator one of the most important provisions on the essence of what is happening [2]: “Do not think that I came to break the law or the prophets: I did not come to destroy, but to fulfill.” Here, as if every person, the Creator pushes to modesty and caution in questions of interpretation and mastering of the fundamental factors of the existence of everything. The Creator, as it were, hints at the fact that the goal of man, as a unique phenomenon of nature, lies in the task of intermediate and more modest. a man as

it should understand the inevitability of his monstrous limitations by the standards of the universe, but the evolution of the civilization of people in the universe fully compensates for this seemingly significant drawback.

Definition No. 1. Consciousness is not the source, the existence of everything, but it is a powerful source of influence on this very thing [3].

The fundamental difference between the Laws of Nature and the normative legal acts created by man is that the payment for overcoming the actions of natural laws occurs immediately, while in the second case a time interval of indeterminate magnitude arises.

Werner Heisenberg [4, c.267], analyzing the transforming forces of the future, cautiously appealed us to modesty: “Remember that great revolution two thousand years ago, the initiator of which, Christ, said: “I came not to repeal the law, but to fulfill it.” I repeat, the whole point is to limit one important goal and change as little as possible. The little that will be changed, at the same time can then manifest such a transforming power that it will almost completely rebuild life forms. “The Creator added to himself: “And not only life ...”, bearing in mind the fact that for many billions of years the minds of mankind have been agitated by the super-intrigue connected with the search for the answer to the most sacramental question: – What is the essence of everything?

For the sake of justice, it should be noted that already at an early stage of their development, people fully understood the unity of the actions of matter, within the framework of the operation of fundamental laws. So – Johann Gottfried Herder (1744–1803), once remarked that “If there is a God in nature, then He is in history, and man is subject to laws no less excellent than those by which the heavenly bodies move” [5, P. 187; 6, T. 13, P. 169].

Yes, not everything is in the Creator’s power, but He can do much. And, perhaps most importantly, it is his ability not only to predict the effects of the transforming forces of Nature, but also to exert a significant influence on the very process of action of these forces, i.e. the process of action of the main laws of nature, according to which everything is necessarily born, exists and dies. And, it concerns not only the Universe as a whole, but also each of its parts separately, including Himself. But, despite everything, enlightened people still liked to call him simply – the Creator. He liked it, too, although sometimes the Conscience “stuck”.

In the end, waking from memories and reflections, he noticed that the wormhole was expanding inevitably, and a sense of conscience and responsibility embraced his mind more and more. Oh, this responsibility! How many problems people had with it! They for, the most part, did not understand for a long time: what is this in essence? They did not understand that conscience is not a structural element of consciousness, but its cocoon and that only conscience is the basis of decision-making responsibility. Really existing is not equability of the properties of responsibility with respect to the consequences of decisions or actions committed involves the clarification of the very concept of responsibility.

Definition No. 2. Responsible is not one who is ready to bear responsibility for what he has done, but one who does not allow the act for which responsibility is established [7].

Obviously, any act (impact on an object) is the transfer of an object from one physical (including emotional) state to another. It means, that any action is preceded by a decision making procedure. And only the maximum adequacy of the solution to the expected result determines a sufficient level of quality of the result obtained. So the solution should be conceptual, i.e. this is when in its elaboration the whole superposition of circumstances and laws acting on the alleged act is taken into account. Thus, a responsible decision in its essence must be – conceptual. However, the conceptual assessment, the essence of what is happening, is impossible without taking into account unobserved factors, because in reality any kind of human activity is associated with unobservable factors.

Definition No. 3. Unobservable factors, this is essentially an almost infinite set of unknown, underlying the movement of natural and emotional phenomena observed by man [8, 9].

From this definition follows that the ratio of the observed (ie, conscious knowledge of a person) to the unobserved (ie, unconscious knowledge) is always less than one, and its magnitude determines the level of the individual's intelligence, the inverse of this ratio is the probability of the risk of existence or simply – life. These two parameters are individual for each, here are some illustrations on this topic:

1. Management under implicit risks. Since they (these risks) are not observable, they do not seem to exist, but there are managers who have learned how to pre-

dict them, based on intuition and logical constructions, and thus control unmanaged factors.

2. Economic activity of entrepreneurs. He (at the entrepreneur, not to confuse with the businessman) as a rule there are almost no means, however the most perspective projects are created by him.

3. Activity of the top-managers. Many other means are also sufficient, but only a few achieve devastating success.

4. Military service. All commanders believe that they know how to command, however, battles are won by few.

Finally, the Creator, in a state of moral exhaustion from such profound reflections, asked himself an almost cynical, but still rhetorical question: “And why is He really needed?” There was a pause in his reflections, he cunningly smiled to himself and with humor remembered a similar response of the famous writer Voinovich V.N. on a once asked him when meeting with a friend is no less a rhetorical question: “How are things, friend?”. Voinovich replied:

Things were going badly,
But not that very badly,
You can even say that it's good,
But from year to year it's worse.

At that moment, against the backdrop of an emotional leapfrogging, he felt – the time has come! He has long been troubled by the fact that the giant evaporation of a black hole is about to begin. Although up to this point he still has enough time for his great mission, which requires the fulfillment of a great number of prescriptions, was duly executed. However, the experience of his existence suggested that time should not be lost. It's time to act! But how? Where to begin? Here, the wisdom of the Creator and common sense prompted: “Do not rush, first you need to harmonize the basic principles and the clasps created by everything, i.e. material and spiritual.” Yes, this is a wise decision, he thought, and in an emotional burst he exclaimed: “Wisdom, what is it?” At the same time he remembered how once a famous writer Fazil Iskander noticed, that wisdom is a mind insisted on conscience, even earlier Rene Descartes would legitimately add that knowing a few principles reimburses ignorance of many factors. The Creator always liked these arguments, but he nevertheless put the fat point: “Private does not create a common, but sometimes cancels it.” On this, he put his emotional essay aside and focused on the necessary

and sufficient conditions that ensure the systematization of the three fundamental principles of the existence of everything, especially since, according to Claude Adrien Helvétius: “Knowledge of the principles compensates for ignorance of certain factors.”

The first principle: the existence of all: – “Nobody”, including the Universe, can not create itself, but what has already been created necessarily has its maternal origin. The process of creating everything takes place in the boundary region of two immiscible environments. All the fundamental physical parameters of the created are limited, i.e. are not infinite. The fundamental properties of the created, scaled on the basis of a geometric progression, and the destruction of the previous symmetries occurs at the points of the geometric mean [10]. Any Universe consists of matter of a single and composite, and part of the compound matter can be alive. All matter on an elementary level consists of an unobservable substance, the vibrations of which form elementary things that have energy, from which a single and composite matter is formed.

Here the Creator stopped in the enumeration of the main factors of existence of everything and remembered the principle of his existence, according to which he himself and everything that was created by him and everything that will be created in the future will necessarily be destroyed. Even he could not break the basic law of existence of everything: “Everything born, it is necessary to create a similar and certainly die”, i.e. no one can exist for an infinite time.

The second principle: the goal-setting of everything: – All created has its goal setting. Not understanding the purpose of the substance of what is happening does not mean its absence. What will happen to the Universe when there are no people? The Creator, having in view of himself, almost sarcastically, answered, that if the Universe can exist without a human being, it means that someone else needs it!? If there is no point in the existence of everything, then why does something exist, that wants to know this most all? And if everything exists in the existence of everything, then all that exists and acts must obey the causal logic. Creating things with the maximum level of complexity, this is what the existing everything is doomed in the universe.

Definition No. 4. The supreme goal of the existence of every universe is to create it; “Creator”, but not everyone is capable of this.

The maximum level of complexity can be enjoyed only by him – the Creator. And since the god (according to Einstein) does not play dice, that’s why the Universe is so huge, and that’s why the Universe needs to have sufficient resources and sizes to solve this super task, so that a 100 percent probability of folding matter into a state with higher a level of complexity corresponding to the level of complexity of the Creator. Universes in which this is not achieved are “barren”. Once Heisenberg W. and Bohr N. started a dispute about the meaning of life in which Bohr stated: “No, the meaning of life is that it makes no sense to say that life does not make sense. This is how deprived of all this support is the desire to know the meaning of life.” After this dispute of the great titans should be added, but the Creator has such a support – this is the second principle about the goal-setting of everything.

The third principle: the self-sufficiency of everything: – The basis for ensuring the self-sufficiency of the Universe, in comparison with the original mother resources and the law of conservation of energy, is a balanced system of matter management. The structure of this system is determined by four fundamental interactions:

1. elastic,
2. electromagnetic,
3. gravitational,
4. informational.

These interactions are responsible for the forced motion of matter, i.e. transition of its various elements from one energy state to another. All other existing interactions are derived from these four.

The law of conservation of energy operates only within the existing Universe, but it is violated for the processes associated with the transition of matter elements between the Universes.

The Universe is the Limit of the Creator’s Evolution

People, many thousands of years, through innumerable trial and error, obtained fundamental knowledge of the universe, they always sought to harmonize them with the knowledge of the Creator, while trying to understand the essence and meaning of the existence of the universe, including the various forms of the movement of things, and composite.

The Creator always tried to understand people, to enter their position, but people did not always reciprocate

him, because they did not understand that not everything is in his power. Even when they were at a relatively low level of their development, people still tried to understand: "What is it that moves the Stars?" The Creator understood naivety of these people, he again with a smile remembered how he read on one plate in ancient Egypt the inscription from the hieroglyphs:

When people find out what moves the stars,

The Sphinx will laugh and life on the Earth will run out.

Perhaps the Sphinx once laughed, but this moment is not fixed in the history of the Universe. However, the moment when people really realized the essence and meaning of the existence of the universe is fixed, as it was the moment of the world evolutionary transition of the higher living matter in the Universe from the biological species (*Homo sapiens*) to the bionic form (*Homo creator*).

At this point of his reflections, the Creator again pondered, put aside the historical emotions and went on to find solutions to the incredibly complex problems associated with the ordering in the mind of the essence and meaning of fundamental knowledge about the Universe. At the same time, he saw his main task in the fact that the process of creating the universe, for which he must observe and control its evolution, strictly corresponded to the basic principles of the existence of everything. He understood that the answers to the basic questions about the Universe are extremely complicated; he also understood that the logic underlying these answers is related not only to physical and mathematical calculations, but also to their philosophical justification. The methods of philosophical substantiation were not always given to people, as most of them even liked to philosophize about things, but even philosophers themselves did not want to learn these things, what to say about ordinary people. That's a problem! However, there is nowhere to go, I'll have to philosophize, too, he thought, and decided to start with the most difficult, from the most important, from the most exciting people question.

What is the Universe?

Many answers to this question are based on a number of contradictions, mutual exclusions and inaccuracies, which probably explains the absence of the definition of the concept of the universe in almost all authoritative encyclopedias of the world. If we summarize most of the

existing definitions, then the result is reduced to the following sentence.

The Universe is an infinite space that includes all, that exists.

However, it is not difficult to prove the inability of this definition by contradiction.

First, the contradiction of essences.

If everything is within an infinite space that is itself devoid of the essence, then it exists not materially, but is speculative.

Obviously, all things are made up of things, the very existence of which is determined by the fact that these things have energy, i.e. are a material substance.

Thus, in this logic there is a contradiction connected with the fact that the material substance can not be in the speculative substance! This conclusion is also implicitly confirmed by the fact that the etymology of the word Universe, as it tells us, that something is embedded in something, but not for the case when the existent is put into speculative. This contradiction is also based on the problem associated with the violation of the rules of the theory of representations, prescribing an etymological correspondence in the use of concepts with heterogeneous properties.

Secondly, the contradiction of infinity.

If the space filled with the essence is infinite, then the being in this space has infinite energy, which contradicts the first principle of existence of everything, since everything that exists can not have infinite physical parameters.

If the space of the Universe is infinite, then what is the meaning of its expansion beyond infinity, and even with acceleration? Absurd!

But the existence of the universe with similar properties was not believed even by Newton and Einstein themselves! True Einstein jokingly said that in this world there are two infinity: the first is the universe, and the second is human stupidity.

If the space of the universe is infinite, and the time of its expansion from the moment of the big bang (BB) is finite, then the size of the universe is determined by the Space within the event horizon, which indicates the closed nature of the Universe, and therefore the physical space beyond the event horizon has the right to be filled with other Universes.

On the basis of the third principle of existence of everything, the motion of various forms of matter in the

universe is determined by the central forces that cause the motion of matter along exclusively closed trajectories, i.e. oscillatory or circular, and hence there are no grounds for the appearance of spatial infinite trajectories.

Thus, the concept of infinity can exist only in speculative and mathematical representations. The rectilinear motion within a certain distance Δx is possible under the condition that $\Delta x \ll L$, where L is the circumference.

Definition No. 5. Nothing can exist for an infinite time.

Conclusion: if the motion of matter can not have infinite trajectories and if the energy (or mass) of the universe can not be infinite, then the obvious conclusion that the Universe in the most basic parameters is limited (or closed), and therefore it is logical to assume that it is not unique; not absolute, there are just a lot of them. And if there are a lot of them, this means that not all beings enter a particular universe, because the spatial regions of different universes can overlap.

Definition No. 6. There is no thing in nature, in which it would be desirable for everything to be.

Finally, the Creator proceeded to formulate an adequate definition of the concept of the universe, but still decided to focus his attention on two points.

1. He liked the greatest concreteness of the poet Mayakovsky V. logic:

If you want a cow's name,
You must have milk and udders.
And if you are without milk and without udder,
What's all in your cow's name.

2. As applied to the subject of this work, it is necessary to further clarify the interpretation of some of the most important concepts that define the fundamental properties of the universe.

Mind is the ability of living matter to think and operate with information, in the process of **cognition**, ie, acquiring knowledge about the environment.

The phenomenon is everything that is sensually perceived by the mind.

A thing is every phenomenon of nature that is known by mind.

The existing things are:

Real, i.e. observed, as well as unobservable, because science has not yet mastered the methods of their observation.

Unrealistic, i.e. unobservable, and therefore virtual, but their existence is proved by the fact that the results

of the interaction of their representatives among themselves can be realized in real form.

Essence is really existing observable and unobservable things.

The essence is the true content of the thing.

Sense is the meaning of truth realized by the mind.

A factor is a distinctive property of something.

Convolution is the result of the process of creating composite matter.

Complexity – determines the properties of compound matter as a whole, with each internal constituent part not possessing the properties of the whole.

An object is a convolution of matter, as a result of which it has the highest level of complexity in comparison with any constituent part of it.

Birth is the process of convolution of matter, as a result of which an object copying the properties of the existing is formed.

Creation is the process of convolution of matter, as a result of which an object is formed, that has the highest level of complexity, not only in comparison with any constituent part of it, but also with any object of the surrounding reality.

The Creator knew much and could do much. However, only in adulthood, he realized the fact that for His (i.e. His) creation required the “Life” of the whole Universe! He now felt that with His omnipotent powers, it would not be difficult to create the universe and create oneself like that. However, on this score, he was very wrong! And only after a significant time, when the period of his wisdom came, he really felt that not everything was in his creator of power. At last he realized finally that he can not act as a mother's beginning for the creation of the Universe, because he is the product of her evolution.

Eventually, as a result of profound physical and philosophical reflections, he developed the following definition of the Universe.

The Universe is an object created on the principles of goal-setting and self-sufficiency, it is an evolutionarily existing set of things, the substance of elementary matter of which is formed as a result of the giant evaporation of the black hole of the maternal Universe.

Concluding this work, it seems quite appropriate to pay attention to the words of a famous actor of theater and cinema – Zeldin V.M., who for 70 years of service

in one theater has played many remarkable roles. So, on February 10, 2015, at one of the events in honor of celebrating his 100th birthday from one of the television programs, he stated: “The worst thing in life is to see the world as it is, without noticing at the same time what it should be like”.

References:

1. Barykinsky G.M. / The universe of consciousness and the picture of the world // Mat. The VII Russian philosophical Congress, – 2015. – V. 2. – 117 p.
2. The gospel of Matthew, chapter 5, verse 17.
3. Barykinsky G.M. / Philosophical observations on the principles, laws and sustainable development of society // Mat. The 1 Russian philosophical Congress., – 1997. – T. 4. – 21 p.
4. Heisenberg W. / Physics and philosophy. Part and whole. Per. Akchurina I. A., Andreeva E. P. // – Moscow, Science, – 1989.
5. Lavrynovych K. / Albertina. Essays the history of the University of Koenigsberg // Kaliningrad, – 1995.
6. Zatsepin I. / About life. // Therapeutic journal published by I. Zatsepin., – 1837.
7. Barykinsky G.M./ The psychology of responsibility and consciousness. // Mat. The II- All-Russian scientific conference on psychology. Yearbook of the RPO “Methods of psychology”, – 1997. – V. 3. – release 2, – 18 p.
8. Barykinsky G.M. / Psychology person in environment unobservable factors // – P. 16–17.
9. Barykinsky G.M. / Implicit risks and the management of uncontrollable factors. // Mat. the 4th international conference “problems of emergency management”, – Moscow, – 1997. – 98 p.
10. Barykinsky G.M. / The law of scaling of fundamental properties of elementary particles. // The European Journal of Technical and Natural Sciences, PP., – Vienna. – 2018. – No. 1.

Section 13. Philology

*Iplina Antonina Alexandrovna,
Poetess, member of Writers' Union of Uzbekistan,
Ph D researcher, Namangan State University,
Namangan, Uzbekistan
E-mail: antipmoon@mail.ru*

ORIGINAL POEM RECONSTRUCTION FEATURES

Abstract: In the article some poetry translating problems in comparative and contrastive aspects are revealed. Translator's skills in Uzbek poetry genre are with due account taken of philosophical seriousness, composition, conditional and epic characters, specific features of images, language simplicity, intonation and author's manner. The Uzbek poetry of the seventies-eighties of the 20th century represented by its brilliant poet such as Abdullah Oripov in its original language and four translations into Russian which are analyzed and compared in the aspect of "form and content".

Keywords: poetic picturesqueness, translating skills, means of language, original poetry reconstruction in translation.

Getting started with the translation of a poetic work, it is necessary to conduct a deep analysis, because the unity of the verse is manifested at the metric, intonation, syntactic and semantic levels. Thus, any piece of poetic art represents a complex interaction of many factors [1].

So, comparing the Uzbek and Russian poems by the number of feet, you can identify the problem of recreating the original in translation. We offer to consider and study the poem of Abdulla Aripov "Тилла балиқча" [2]. (Золотая рыбка / A Gold Fish), which is one of the most famous of the poet's works, in details in the original Uzbek language:

*Тухумдан чиқди-ю, келтириб уни
Шу лойқа ҳовузга томон отдилар.
Ташландиқ ушоқ еб ўтар кунни,
Хору хас, ҳазонлар устин ёндилар.
Дунёда кўргани шу тор ҳовузча
Ва гамжум толларнинг аччиқ ҳазони.
Менга алам қилар, тилла балиқча
Бир кўлмак ҳовуз деб билар дунёни!*

(Word-for word translation: From the egg hatched, brought her/ Threw to this clay pond./ The livelong day feeds abandoned drops./ From above garbage and fallen

leaves cover./ Looks at the world through this small pond/ And the bitter leaves of many willows./ It hurts me that goldfish / Knows the world on a pond like a puddle.)

One of the most important aspects of the comparison of translation with the original is the degree of accuracy in the transfer of the main characteristics of the original work by the translator. The poetic text, as was repeatedly emphasized by the researchers, has a multidimensional character. It is characterized by a complex interaction of different levels, reflecting both the general laws of the language, and purely specific plans (rhythm, stanza, phonetics). The last ones impose restrictions on the text, requiring to comply with certain metrorhythmic standards, are organized on the phonetic, syntactic, lexical levels [3].

Also, an important characteristic of the poetic text is its imagery. The very concept of the image has different interpretations. Most traditional approaches are to understand the character of those associations which they are generated, as either type of the path or shape of the underlying opposition (or, conversely, based on communication) of two or more associated words in the text [4].

In the short poem of A. Arhipov "A gold fish" it was created an image that contains great meaning. Here-another "sharp edge" of modern life. Goldfish, born in an abandoned pond, does not suspect that there are other water spaces in the world. This small space is the whole world for her. That's where the climax of poetic thought! After all, many more can be found in the lives of people like this Golden fish, who are looking at the world only through their narrow, smoky stench of the "window". Against them such a poem as "A Gold fish» was written (from a personal conversation with the author of the original).

Obviously, there are several ways to transfer an image while translating. Thus, the translator can convey the image accurately, replace one of the elements with another, or replace both elements of the model by entering his own image that is not presented in the original.

Let us consider the specific expression of different strategies of translation of the poetic imagery of this poetry in more details in Russian. Today there are four poetic translations of this poem known. Each of them has its own interesting and reports originally the plastic and the music of the original. We will try to analyze the degree of their proximity to the original, their achievements and failures, and of course, which of the translations conveys most fully the originality of the original. Version of A. Feinberg's translation: [5]

*Осенний пруд. Витает паутина.
Плывеешь. Твои моря не глубоки.
Среди кувшинок, зарослей и тины
Мерцают золотые плавники.
Откуда здесь ты, рыбка золотая,
Гнилые сучья. Комары. Туман.
Плывет спокойно, ничего не зная,
И мнится ей, что это – океан...*

So, his translation at first glance, is far enough from the original. Almost all text of the poem is abounded with inaccuracies, and only the last two lines correspond remotely with the thoughts, expressed by the author of the original. As a result, it can be called rather a variation on the theme – the translator approached the reproduction of the original so "creatively". Thus, the seeming freedom in the deployment and interpretation of the author's ideas, adapting them to the values of a different culture can give a new life to the product. But without accepting the author's idea, the translator could not fill the original adequately. Although he managed to achieve

imagery, content and artistic structure, expression using the lexical means of the Russian language, he adapted and Russified this poem. Therefore, in general it is the least successful translation of this text.

Translated by A. Naumov: [6]

*Едва от рожденья – попала она
в тот грязный, заиленный хауз,
и крошки ловила, и илом со дна
играла,
и в нем задыхалась.
И всё, что на свете ей видеть пришлось –
лишь хауз, да палые листья
разросшихся талов,
да небо, насквозь
прошитое веткою лысой.
Лишь хауз заброшенный с грязной водой
с листвой полусгнившей
да илом...
И горько, что рыбке моей золотой
вот это –
и кажется миром.*

The variant proposed by A. Naumov is also not quite successful. His text conveys the content of the original very freely. Arhipov's "simplicity" emotionally pumped excessive phraseological repetitions of the description of habitats of fish that creates a very dull picture. It follows that the translator was deeply imbued with an emotional state to convey the landscape of the poem, which resulted in an increase in the volume of the poetic work from octet to three quatrains, where verbosity does not contribute to dynamics.

Translation by H. Mamatova: [7]

*На свет лишь только появилась,
Как тотчас же её
Забросили в этот грязный пруд.
Под слоем мусора, средь ила
В охоте за гнильём
С тех пор спокойно дни её текут.
И много лет она лишь только знает
Свой тесный пруд да горечь листьев ив.
Обидно мне, что рыбка золотая
Живёт, в лоханку целый мир вместив.*

H. Mamatova has a similar situation with A. Naumov. Trying to get closer to the original and convey the Eastern style and intonation, it increased the volume of the verse to 10 lines, as well as the structural organization

of the verse. As you can see, in her variant “fractures” of rhythm are observed in the first six lines, where the first one rhymes with the fourth, the second one with the fifth and the third one with the sixth stanza.

And that’s how the poem looks in the translation of M. K. Khamraev: [8]

*Когда икринкой быть чуть-чуть осталось,
Её забросили в наш пруд заросший.
Отбросами кормилась и плескалась
Она в воде несвежей, нехорошей.
Что видела она на глади зыбкой?
Траву и листья, дно с вонючим илом...
Обидно мне, что золотая рыбка
Прогнивший мир считает целым миром.*

Choosing iambic pentameter and saving eleven syllabic, M. K. Khamraev managed to prosper closer to the original, unlike his predecessors. His octet is the closest to the original in content and form. Thus, he creates a melodic atmosphere of Arkhipov’s sad chant. The translator is also good at intonation: the phrase is covered naturally, freely and easily by the stanza. It can be only argued against expressive expression «вонючий ил» – “smelly silt.” This excessive verbal clarity “breaks” into lyrical

lines roughly and vulgarly. M. K. Khamraev does not use a substring, and translates directly from the original, that is why he retained almost all the features, that became the result of a more successful version of the translation. After all, he approaches the translation not only as a poet, but also as a literary critic, bilingual, fluent in Russian and Uzbek languages.

The only thing that really fascinates and at the same time unites all four translators is that they were able to adequately reproduce the wisdom, philosophical conclusion concluded in the last two lines.

Thus, looking at the above translations, we will see that the translator-poet does not give up his view of the landscape, and is not exempt from his own optics. In this case, it would be appropriate to quote the words of Ya. I. Retsker: “The product of a truly high lyric has an infinite semantic perspective, and therefore it is possible not only one translational solution, but theoretically, an infinite set. If we are faced with a number of talented, artistically holistic translational options, it is not easy for any of them to give unconditional preference, since the translations of the same thing reveal a brilliant original from different angles» [9].

References:

1. Варфоломеев И. П. Введение в литературоведение. – Ташкент, – 2006. – 108 с.
2. Орипов А. Танланган асарлар, 1-ж. – Тошкент, – 2000. – 75 с.
3. Баевский В. С. Основы поэтической системы. – Смоленск, – 1993. – 14 с.
4. Павлович Н. В. Язык образов. – Москва, – 1995. – 20 с.
5. Арипов. А. Удивление. Стихотворения. – Ташкент, – 1985. – 71 с.
6. Арипов. А. Ветер моего края. – Москва, – 1988. – 143 с.
7. Кошчанов М. Жизнь моя-поэзия // Звезда Востока. – Ташкент, – 1985. – № 11. – 137 с.
8. Хамраев Ф. Горение, или продолжение жизни // Преподавание языка и литературы. – Ташкент, – 2001. – № 1. – 73 с.
9. Рецкер Я. И. Теория перевода и переводческая практика. – М., Международные отношения, – 1974. – 63 с.

*Martashvili Nato Elberdievna,
Ph D., in Philology,
Tbilisi State University,
E-mail: nato.martashvili@yahoo.com*

NATURE OF CORRELATION OF THE TITLE AND LITERARY TEXT (ON THE BASIS OF FRENCH LITERATURE)

Abstract: The two basic types of correlation of the title and text of French literary works are simple correlation, when the title transmits only factual information and no subtext is born and complex, when the correlation between the title and the literary text creates new, conceptual information. Under the above two types of correlation various subtypes of the titles can be distinguished.

Keywords: Titles, French literary texts, correlation, conceptual information, Symbolic title, Metaphorical title, Intertextual title, title-pragmeme, title-prodrome.

The title of the literary text is considered to be the sign, the semantic radius of which spreads over the entire text. It comprises in the compressed form information that is further extended in the text. [5, 27–28]. It is an integrating element denoting the concept of the entire text [5, 133–134]. From the structural-semantic viewpoint the title represents a starting point in the creation of the concept of the text [6, 31–33].

The title contains either the content of the text [1, 5] or the author's message, expressed either explicitly or implicitly. Thus, the title can be considered as a micro text [2, 34] that can exert a more or less powerful influence on the reading process.

The relationship between the title and the literary text can be of different depth. In the scientific literature devoted to the study of literary titles two forms of the relation between the title and the text are pointed out: explicit and implicit. The explicit relation is superficial and implies the repetition of the title-words throughout the text and especially in its strong positions i.e. in the beginning and the ending of the text. Implicit is regarded a relation that creates new information in the form of subtext [4, 26–32].

Our observation over the titles of French literary texts has shown that the creation of a subtext i.e. new information can be detected not only in implicit relations but in explicit relations also (we will consider this issue below) and since this phenomenon is of essential importance in the correlation of the title and the text, we prefer to differentiate the relation between the literary title and

the text based on this parameter i.e. on the parameter of creating a subtext.

The present article deals with the issue of the nature of correlation of the title and the conceptual and thematic essence of the literary text the nomination of which it is. As a result of a scrupulous study of the problem, the two basic types of relationship between the title and the text are detected – the Simple and the Complex. The relation is Simple, when the title is limited to transmitting only factual information and the relationship between the title and the text does not result in producing new information. The relation is Complex when as a result of the relationship between the title and the text new information, a subtext is created, which by its nature is conceptual information. In accordance with the above two types of relationship between the title and the text, the titles fall into two basic types:

a) Simple titles, among which the Simple title-prodromes and the Simple title -pragmemes are distinguished and

b) Complex titles that fall into two main subclasses of the Complex title-prodromes and the Complex title-pragmemes.

Simple title-prodrome announces in an explicit form the events narrated in the text or names the protagonist of the literary text. So, the reader expects the development of the occurrences the title announces about, and he is not disappointed. This is the rudimentary, primordial function of the title. Simple title-prodromes are common in the nineteenth century, e.g.: “Carmen”,

“Matéo Falcone” (Mérimée), “Nana”, “Thérèse Raquin” (Zola), “Louis Lambert”, “Eugénie Grandet” (Balzac), “Yvette”, “La légende de Mont Saint-Michel”, “Une aventure parisienne” (Maupassant) etc.

Simple title-pragmeme, explicitly expresses the author’s evaluation of the event or the character under consideration. Therefore, when reading such a title, without knowing the text the reader already knows the author’s attitude towards the character or the phenomenon of the literary work, e.g.: “Les misérables” (Hugo), “Splendeurs et Misères de courtisanes”, “Une ténébreuse affaire” (Balzac) etc.

The titles of complex relations with the text have one of the privileged significance in the pragmatic dimension of the text. The semantic dynamics of a complex title goes along the path from pressupposition to implication. In other words, the semantics of such a title passes through three mental stages in the mind of the reader: Ante lectio, In lectio, Post Lectio. Ante lectio is the beginning of impressions that stimulate the imagination system, in lectio – when certain images appear in the perception system; post lectio – when already generated images are modified and become abstract.

Complex title-prodrome similar to the simple title-prodrome, describes the events of the literary work and names the theme explicitly, but unlike the simple title-prodrome it: a) can create new information, a subtext; b) is a means of deciphering the intentions of the author; c) it is fully opened only post lectio i.e. its meaning is comprehended retrospectively.

What are the means, facilitating the creation of new information and how is the subtext created by Complex Title-Prodromes? Our observation has shown that the frequent repetition or the play of the title words in the text contributes to the semantic transformation, to be more exact, the significance of the referential situation transmitted by the title goes beyond the text space and causes abstraction and generalization of the subject of the literary text. A good example of the complex title-prodrome is the title of Samuel Beckett’s play “En attendant Godot”, which explicitly names the process described in the play, but the frequent repetition of variations of title-words in various contexts of the literary text (namely: – “Allons-nous-en. On ne peut pas, on attend Godot.–C’est vrai” – five cases; “Qu’est-ce qu’on fait maintenant? – On attend Godot.–C’est vrai” –3 cases) contributes to the creation of the subtext and the title acquires an almost philosophi-

cal depth. Here post lectio, a concrete theme acquires general and abstract features and the subtext, created as a result is the absurdity of human existence.

Complex title-pragmeme unlike simple title-pragmeme, implicitly contains an evaluative implication that is a kind of intellectual and emotional message from the author. Thanks to such title the author finds an opportunity to express his ideas about the story, where the narration of the text is most often neutral and nothing points to the author’s attitude to the described phenomena. Such titles are presented:

a) with expressions comprising stylistic figures/devices – these are **metaphorical titles** in a broad, Aristotelian sense of this word, including in itself all the stylistic figures. Such titles contain a moral credo and subjective vision of the author and represent conceptual information. Metaphorical titles, which at first glance have no relation to the text, open up and reveal themselves either in lectio in the context of the literary text, or post lectio, after the profound comprehension of the text. Retro-reading of the metaphorical titles demonstrates axiological attitude of the author to the phenomenon under consideration and reveals the conceptual information of the text, e.g.: “Vipère au poing”, “La mort du petit cheval”, “Cri de la chouette”, “L’église verte” (Harvé Bazin); “Le baiser au lépreux”; “Le noeud de vipères” (Fr. Mauriac) etc.

b) with certain details of material significance taken from the entourage of the protagonist presented in the text – these are **symbolic titles**. Since the basic principle of the symbol is to present something invisible by something visible, this mysterious title has connotative abilities and functions as a part representing the whole, as a synecdoche or metonymy. Symbolic titles are the suggestive signs with the power of semantic reconstruction of the text. They determine the direction of the narrative of the text and consequently provide the depth of the text. Such titles acquire symbolic meanings in lectio or post lectio, e.g.: “Les Allumettes suédoises”; “Trois sucettes à la menthe” (R. Sabatier);

c) with one or more intertextual words – these are **Intertextual titles**. Such titles provoke linking chain with the associations of the source text and confer abstractness to the literary text, the titles of which they are. The Intertextual title is a powerful pragmatic means that focuses attention on the most significant (person or event) in the

novel that is in full compliance with the intentions of the author, e.g.: “Sodome et Gomorrhe” (M. Proust); “Lève-toi et marche” (H. Bazin), “La porte étroite” (A. Gide), “Génitrix” (Fr. Mauriac) etc. The author by choosing the title gives a clue to his intentions to the reader, since it is exactly the title that determines the reading orientation for the reader. That is why the process of choosing the title is very challenging for the author and the title chosen by the author is so important for the reader. G. Genette asks a question: how would we read “Ulysses” by Joyce if he had not entitled it as “Ulysses”? [3, 8], because the intertextual title encompasses the entire narrative system of two texts, establishes associative cohesion and determines the spectrum of reading. New information provided is information pertaining the author’s thoughts and worldview.

Types of titles with a complex correlation with the text allow the reader to retrospectively read everything that is explicitly missed out or intentionally omitted.

U. Eco notes that the title should contain some mystery and should not provide too much clues to the reader. Since the XX century and to this day the authors consider it important to present in the literary title their personal concepts, their intellectual and emotional outlook of the world, their individual vision of the narrated events by means of all kinds of stylistic figures, symbols and intertextuality in the titles. The title becomes a real arena for creativity, thereby destroying the traditional concept of the text space. The title of a complex type in relation to text combines in its expression the quintessence of a literary work.

References:

1. Heok L., *La marque du titre*, Paris, La Haye: – Mouton, – 1981. – 5 p.
2. Adam J. M. *Pour lire le poème*, De Boeck. Duculot, Bruxelles / Paris, – 1992. – 34 p.
3. Genette G., *Seuils Le Seuil*, coll. “Poétique”, – 1987. – 8 p.
4. Джанджакова Е. В. Смысловая сущность заглавия и его перевод (на материале рассказов А. П. Чехова) // Моск. гос. лингвистический универ–ситет. Сб. науч. тр. Вып. 393. – М., – 1992. – С. 26–32.
5. Гальперин И. Р. Текст как объект лингвистического исследования. – М.: “Наука” – 1981. – Р. 27–28; 133–134.
6. Martashvili N. E. *The phenomenon of literary title*, monograph, – Tbilisi. “Universal” – 2010.

Section 14. Philosophy

*Nishanova Ozoda Jalolitdinovna,
National University of Uzbekistan,
Tashkent, Uzbekistan
E-mail: naumenko06@mail.ru*

FUNCTIONS OF ETHNIC CULTURE

Abstract: In this article, some aspects of ethnic culture functions philosophical understanding are considered. The aim of research is characterization of ethnic culture main functions. As a result, author shows such functions as preservation of cultural wealth (museum), realization of the world, knowledge (gnoseology), communicative, globalization, integration, recreative, creating artistic-aesthetic wealth.

Keywords: culture, ethnic culture, functions, gnoseology, lifestyle, folklore, values, aesthetic.

The factors such as life style, family economical life, tradition and ceremonies, religion and religious imaginations, gnoseological experiences, folklore, literature and art, popular performances occupy important place in comprehension of ethno culture as a social-historical and artistic-aesthetic reality. Above mentioned different factors raise to a much higher level of ethno cultural reality after they carry out ethno psychological synthesis. Transformation of a certain custom, a word or experience to ethno cultural reality is not mere a tradition, an imitation on the contrary, they must go through superintendence of spiritual-psychological experience of people, its ethno psychological synthesis. Artistic-aesthetic wealth not inculcated on spiritual-psychological experience of the ethnos, not met to requirements of ethno psychological synthesis, cannot take up in the ethno culture [1, P. 444–446]. In that way, things – artistic-aesthetic wealth, values, which are organic parts of the ethno culture, must take up in spiritual-psychological life of people, nation by going through ethno psychological synthesis. From that point of view, there are two kernels – upper stratum changing every other day, exposing to transformation, sometimes denying itself and stem stratum introduced into ethno culture, consisted of permanent artistic-aesthetic wealth in the national culture.

The upper stratum and stem one is connected in dialectician, they always exert influence over each other. When external influence is increasing, consciousness, imaginations, life style of a man are constantly changing at present; the upper stratum of culture is acting too actively. Mass media, urbanization, processes of modernization, international relations, integration, global changes made section of the upper stratum of culture widen. It is a term of development of culture by adapting to social-historical necessity.

Eternal, everlasting values of the ethnos, its traditions, and artistic-aesthetic wealth are incarnated in the ethno culture. The ethnos feels, is conscious itself as everlasting ethnic unity through its above-mentioned values, traditions, artistic-aesthetic wealth. Though new generation submit to the influence of upper stratum of culture, the ethnos does not refuse its everlasting, eternal values, traditions, artistic-aesthetic wealth, on the contrary, it always endeavors to preserve, develop them. Eternity, immortality are ideas which have important significance for the ethnos. It knows that it can only provide its eternity, immortality through stable, permanent wealth. If the ethnos considered things created by life temporary, ineffective, it did not invented a new thing suited to eternity by exploring constantly and feeling mental trepidation and lived in accordance with the propaganda “eat, drink,

enjoy” by Epicurus. Genius of people is that it tries to create things, which serve for future, made its life eternal. It is possible that only some persons regard culture as an amusement that they consider all things temporarily and recognize the life provisionally but people, nation cannot do like that, it needs eternity, immortality. Thus, people and nation provide their immortality, eternity of the life through creation of cultural wealth.

General functions of ethno culture in the philosophical references describe the following:

- preservation of cultural wealth (museum);
- realization of the world, knowledge (gnoseology);
- communicative;
- globalization;
- integration;
- recreative;
- creating artistic-aesthetic wealth.

The function of the museum is aimed to preserve wealth turned into a stem part of culture, created in the process of social-historical development. In fact, the word “museum” means senses of collection, accumulation, preservation. We use it as sense of a saver, a collector of cultural wealth, too. People, nations try to preserve their cultural wealth through traditions, ceremonies, folk-lore, art, books, and historical monuments.

The function of the museum is aimed to preserve cultural wealth created by our ancestors, to defend from inciting influence of alien elements and destruction of merciless social-historical processes. Traditional character is a phylogenetic and ontogenetic phenomenon peculiar to a man. It carries out a task of preserving the ethno culture through transformation of wealth created by ancestors, of permanent disposition, of moral norms, of lifestyle from generation to generation [2, P. 160]. “Traditions are not introduced into people by force; they are social condition of people developed historically, its life style and everyday life connected with material production” [3, P. 13]. “Exactly person creates traditions and improves, accepts some of them or refuses others” [3, P. 13].

The function of the museum commands profound respect to heritage in consciousness of people, studying them and feeling of development. Continuity in the ethno culture is provided by the function of the museum, too.

The function of the museum also carries out a task of wide propaganda of ethno cultural wealth, artistic-aes-

thetic one, of introduction into consciousness of people and their life style.

Gnoseological function expresses knowledge of the world, environment of the ethnos, experiments of comprehension. The ethnos has had a peculiar spiritual-psychological world, has tried to know environment, the world, it undoubtedly has its own gnoseological experiments. Each ethnos itself understood phenomena, which take place in the nature such as changes of seasons, rise of the sun and the moon, raining and snowing. Some gnoseological explorations that based on the observation and experience of thousand generations have gradually become ethno cultural wealth, feature of the ethno culture and its function.

Today though significance, place of philosophical scientific observations, science-techniques increase, gnoseological experiences of the ethnos, which collected in the process of long social-historical development, have not lost their influence yet. From this point of view, gnosiological function occupies in the stem of ethno culture, its kernel.

Communicative function includes integrative and intermen relations, communications. Therefore, when the language is one of the main means of culture, it expresses itself by help of communication. Communication has been term of development and progress of the ethno culture.

Communicative function is carried out directly or indirectly, obligatory or voluntary, individually or group, popularly by means of signs or gesture.

An individual person is able to create some types of the ethno culture (for example, applied art, poem, dance and so on), but their spreading, transformation to creation of people is bond up with environment, majority. For that, the communication is one of main marks of the ethno culture.

Communication is considered an expression of inner spiritual need aimed in order to change information of a man, in order to learn to this or other news, in order to share feelings gathered in his heart according to its essence and basis. A man has a bearing on either an object of creation or other subjects of creation process in it. Art of witticism has worthy place in communication. “The witticism is popular performance which is held among some people and is constructed according to oral joke and witticism. It can be named “game of word”, “art of laughter production”, “competition of artistic word”. The

main method in the witticism is to joke in way that there a word under a word, that is, there is a cup under some smaller cup (word for word: there is something behind that). It is usually considered a high mastery of word and intentional purpose is to make audience smile in the hall. Proficiency of master of witticism is to use styles of artistic word and its expressions, jokes, musketries and causticities efficiently and in this way, it appears in establishment of communication with other masters of witticism and audience immediately. For that, the witticism has continued to by means of living communication as a traditional form of creation of folk-ore” [4, P. 22–24]. If the witticism had continued to live in family vital circles in the past, today it has become popular-artistic measures organized by cultural centers as an impressionable type of people’s ethno culture [4, P. 25].

Function of socialization expresses that a person his artistic-creation talents, intellectual faculties on progress of society, and interests of ethnos, to be active in the social life. Culture does not refuse scientific, artistic, aesthetic activities of a person, a creator but it tries to demonstrate, to describe his ethnic vital problems more active, wider, in this way to develop itself. By this way, a person participates as a subject in social-cultural life of people, nation.

Function of popularization is found as an external organizational sign of culture but it rises due to approaches of national features of the ethno culture and spiritual interests to each other, psychological unity of close men. Mass character is determined as culture is clear for majority; methods of obtaining it are easy. The culture which has no this sign, does not spread among people, nation.

There have been always integrative signs (functions) in the Uzbek ethno culture. They are connected with such as that they have lived in the same geographical territory with peoples in Central Asia of Uzbek people, they have been identity of their economical-cultural types and social-historical life, they have belonged to one large ethnos – Turkish family and they have been in one religious belief. In addition, it is necessary not to forget that social-cultural values of various people (the Persian, the Arab, the Mongol, the Russian, and the Greek-Macedonian) have been synthesized in Central Asia. These signs have united not only the Uzbeks but they have united the whole peoples in Central Asia in

their circumstance. They instill us into true realization of the history, culture, national customs of these people, comprehension that we have been close nation, family in ethno genius aspect that there have been close signs to culture of Western people (China, Mongolia, India, Turkey, Arab countries, Caucasus) in this culture. It advocates these nations to live around the ethno cultural values in integration.

Recreative function expresses aimed traditions to spend their time of ethnic groups, nation and to restore their psychological condition.

Though rest and relaxation is in his voluntary of a person, it does not take place out of a society, changes which are occurred in the social relegations. Rest and relaxation is connected with interests of a person and social progress in dialectician.

Creation of artistic- aesthetic wealth is a key aim of culture, artistic-aesthetic creation, ultimate result. This function is connected with above-mentioned functions, but participation of a person in creation of artistic-aesthetic wealth is considered a main indicator. If participation of a person is sufficient in social-cultural life for function of socialization, a person must create this or other artistic-aesthetic wealth for function of creation of much artistic-aesthetic wealth. Thus, creation examples, works of a person that enrich national culture, is an ultimate purpose of all culture.

This function leans on an approach that has fundamental importance that it is named that people, nation creates an ethno culture in creation labor, investigations and changes of practice. Creation activity that is, activity in general is way of existence of a man. “Sign in notion of culture of life style of a man is his activity” [5, P. 21]. True, not all activities can create culture yet, but things, artistic-aesthetic wealth aimed an exact purpose, created in conscious, artificial way are culture. Therefore, artistic-aesthetic wealth is a main sign of cultures [5, P. 25].

This function appears in investigations, which are from advancement of available social-cultural wealth to creation of a new creative model in the Uzbek ethno culture. For example, original ornament works peculiar to the Uzbek ethno culture are met with archeological finds concerning the first thousands B.C. [6, P. 8–10]. However, each generation has made his contribution to these too plain patterns, has enriched them with historical-religious imaginations and has risen to level of

modern compound art. "If artistic designs have grown in the models of practical workmanship, we can see subsequent models of imitative art in the pictures in items of ceramics. Forms of earthenware crackers begin to be complicated and to design ornamentations, pictures in earthenware crackers caused thoroughly development of art of the ceramics" [7, P. 15]. In this way, people's applied art has turned into complicated genre from simple appearance in influence of creative activity.

As the types and forms of the ethno culture are different, its aesthetic function appears in various sizes, level in these types and forms, too. Elements of tragedy, low-down action, and ugliness do not appear in people's ornament art and conformity of colours, excitement of aesthetic pleasure

stand in the first place. Nevertheless, it does not mean that there will not be antinomy elements in people's ornament art. Appearance of colours such as dark, green, and cinnamon, blue which come side by side or after red, yellow, dark yellow, vital colours expresses level of artistic-aesthetic taste. Antinomy phenomena are stem, basis of objective being, they are expressed by side by side usage of cold (dark, green, cinnamon, blue), hot (red, yellow, dark yellow, vital) colours. However, a man who knows secrets of its artistic-aesthetic creation well notes truly. In conclusion, the artistic-aesthetic function of ethno culture is to turn into an active subject of social-cultural life through making a man use cultural wealth created by people and improve artistic-aesthetic quick wits according to its essence and aim.

References:

1. Ethno psychological problems: yesterday and today – Minsk: Harvest, – 2004.
2. Arutyunov S. A. Peoples and Cultures: Development and interaction. – M.: Science, – 1989.
3. Nadzhimov G. N. Folk traditions and culture. – Uzbekistan, – 1992.
4. Karabayev U. H. Traditional folk art: problems of revival and development. – Tashkent: Fan, – 1991.
5. Karmin A. S. Basics of culturology. Morphology of culture. – Saint-Petersburg.: Publishing house "Lan", – 1997.
6. Rempel L. I. Chain of times. Secular images and brooding stories in the traditional art of Central Asia. – Tashkent Publishing house of literature and art named after G. Gulam, – 1987.
7. Oydinov N. O`zbekiston tasvir san'ati tarihidan lavalari. – Tashkent: O`qituvchi, – 1997.

Chmykhun Svetlana,
National Aerospace University
"KhAI", Kharkiv, Ukraine
E-mail: svitlana.chmykhun@gmail.com

COERCION MECHANISMS IN TRADITIONAL SOCIETIES WITHIN THE LEGAL NORMATIVITY SYSTEM

Abstract

Objectiv. The article is dedicated to the analysis of the coercion mechanism phenomenon as a critical social influence channel. Social coercion in this context refers to the social necessity, which provides stability in social attitudes structures by the status of the social actors.

Methodological background. The methodological background of the research is formed by the principles of social philosophy and philosophical anthropology. Such methods of philosophic and legal analysis as dialectical approach to the phenomenon and aristotelian method were used.

Conclusions. The environment of traditional formation is structured as a hierarchy. Coercion forces of the traditional society in the philosophic anthropological concept depend directly on the vertical and horizontal coercion types, i.e. on class and personal identification at the vertical level, and on relationships, for instance, at the communication level.

Keywords: coercion mechanism, social influence, self-organization, social relationships.

One of the most important channels of social influence in the society is social coercion. Coercion performs the functions of social management, integration, regulation, social interests protection and social security provision in the society. Sustainable social ranking structured by the status of social actors provides functioning if the society as the "social interaction space", "power interaction field" (P. Bourdieu). Societal life is regulated by the system of normative precepts, which have the coercive nature with reference to individuals and social groups. Social coercion in this context is the social necessity also providing social control.

Today, when reflecting on the control system structure and mechanisms, and trying to develop theories in this context, we are usually sufficed by observations of our contemporaries. At the same time, there are numerous and relatively accessible observation data, which indicate that the behavior control standards and samples may vary at different progress stages. Here a question arises: how simultaneous changes are made to behavior regulation via external and internal coercion mechanisms in the long-term society transformation process, and what influences this. In everyday communication,

changes of this kind are pointed at by saying that in the society people have become more "civilized" than they used to be.

The aim of the article is the analysis of coercion mechanisms taking place in the traditional society in order to establish and maintain the normative order.

The subject of the research covers the means of the traditional society self-organization and self-protection aimed at liquidation, neutralization or minimization of the norm infringing – deviant behavior in the legal normativity system.

The problem of order and social control was discussed by all the representatives of social cognition beginning with Au. Komte, H. Spencer, K. Marx and D. E. Durkheim to P. Sorokin, T. Parsons, R. K. Merton, N. Luhmann etc.

When analyzing coercion mechanisms, some researchers admit that social coercion is the forced behaviour stipulated by the social conditions (situational coercion) (J. Abercrombie, S. Hill, B. S. Turner). Other scientists think that coercion is "exertion of pressure" (T. Lawson). P.-M. Foucault thinks that in every society the body is "gripped in the vice of power, imposing

coercion on it". In the analysis of coercion mechanisms within the framework of the traditional society, philosophic meditations on "the essence of legal coercion as resilience to evil" are particularly interesting in our opinion (P. Suslov). I. Ilin turns to the analysis of the notion "forcing" as "Imposing the will on the inner or external human constitution" relative to them when comparing the notions of "coercion" and "violence". In the modern literature separate kinds of social coercion, primarily governmental coercion, are studied. This is stipulated by the fact that many researchers regard the state as "the monopolist of coercion" (N. Korkunov), and the state itself is often perceived as "the coercion mechanism" (V. Nersesyants). Nevertheless, the philosophic literature lacks works in which social coercion is regarded as an integral social phenomenon. Serious changes in the modern world demand reinterpretation of the phenomenon of coercion from the viewpoint of the modern socio-philosophic intelligence. There arises an urgent necessity in the creation of an integral socio-philosophic concept explaining coercion in the social processes. This explains the topicality of the given work – participation in developing the complex concept of the genesis of social coercion kinds and forms.

English thinker H. Spenser stated that the whole social control is based on "the fear of the living and the dead". Fear of the living is supported by the government while the fear of the dead is supported by the church. These two institutes of emerged and gradually developed in the primitive society. Social control of the human behaviour is exercised by the "ceremonial institutions", which are older than the church and the state, but are more effective.

The traditional type of social relationships, which are typically determined as solidarist and communal, is characterized by the wide range of features and properties studied by different sciences. Research into the system of public control is part of the academic disciplines such as anthropology, political sciences, philosophy and sociology. Despite the great number of publications, the issue of influence of the control system on the relationships emerging within the traditional formation, has not been solved yet. This is connected with the fact that the traditional system was not homogeneous with regard to the existing social ties, divided into the merchant and craftsman's' as well as the knight and the peasant's sys-

tem. Moreover, the study into the control system characteristic of the given type of public formation, constantly brings us in contact with the paradoxical plexus of the polar opposites – the sublimed and the low, the spiritual and the solely corporal, the dull and the comic, the life and the death.

The control coercion mechanism in the traditional society can be represented in subordination to the system: coercion in the form of principal control answered the question of what new things appeared in the given development period of the humankind, then the issue of what kind of coercion and, finally, what coercion instrument was applied to exercising public control.

It is necessary to define the basic criteria, which characterize the traditional society. The system of such society is grounded on the legal regulatory and socio-political, moral and religious, material and cultural as well as socio-psychological control. This approach is characterized by the fact if we refer to the notion of control as a system of social coercion mechanisms regulating individual and group behaviour, which fosters compliance with the rules of the given society or social group, social control is aimed at providing social management goals attainment and is exercised in the following main directions: firstly, formation of utmost limits (conditions), which influence the object's behaviour and within which the object's behaviour is considered desirable and acceptable; secondly, provision of the object's behavioural activity aimed at the set goal attainment externally supported by specific methods and instruments; thirdly, definition and halting deviations from the norms of the socially permissible behaviour.

In order to address the main issue we will need a clear picture of how the traditional social relationships system gradually changed beginning with the early medieval times.

Weak differentiation of various spheres of social life in the middle of the century is well-known. The philosophy, the morale, the law and the legislation process were not fully separated, they intertwined creating a system, parts of which may not usually be harmonized, interacted actively and had a more or less theologic connotation penetrated by religious beliefs. All the forms of human activity in the feudal society were subordinated to the rules, departing from which was forbidden and condemned. Traditionalism of the public practice in the Middle Ages and its dependence on the religion formed

general normativity of the individual's social behaviour. In virtue of this normativity, the law attained the meaning of the universal and all-encompassing regulator of the social relationships.

Control over the individual's behaviour was stringently combined with an extensive system of prohibitions and encouragements. The individual does not face the choice, they follow the examples sanctioned by the religion, the law and the morale. The law and the morale coincide or are close because legal norms have more than one external compulsoriness and are based not only on the punishment system, but are also the imperatives, which have moral and religious value.

As the law was referred to as the old custom, these were references to the old times that added to its standing. Innovation was not perceived in this way, and all the legislative activity took place predominantly in the form of the older law restoration, finding and refining ancestors' customs. The law of the given epoch was oriented at the past. High value of the old custom is characteristic of all the spheres of the medieval life. Medieval traditionalism is not mere conservatism and the rule of tradition. Orientation at the old was seen as particular courage and the old custom ruled over moral virtue. The new provoked distrust and innovative activity was perceived as blasphemy and immorality. "The stones set by your father do not move out of their position...", Vincentius Lerinensis, the Vth century monk, taught. "Because if innovations should be avoided, the old custom should be supported; if the new is filthy, the old doctrine is sacred". [1]

The category of instructions which most directly reflect the legislative activity, primarily includes the Truths of Western European Peoples and Tribes of the Early Middle Ages. The Truths don't establish the legislative initiative of the governors (however, its traces can be found in the legal code section, but this is the reason why these traces can normally be distinguished and studied separately from the rest of the Truths), but primarily and mostly the people's custom. Its peculiarity was extreme traditionalism and irremovability; the norms were treated as unchangeable and, at times, sacrosanct customs, which had more authority on condition of being older. Being old provided for their strength. It is yet clear that customs genuinely did not remain unchanged and they were transformed with time passing but their change mechanism was peculiar.

Customary law records accumulate the social expertise of the given period. The traditional form of the public law reflected social activity which took on the nature of constantly replicated behavioral patterns obligatory for all members of the society. Innovations are not difficult to be distinguished in the Truths and a number of objective phenomena can be outlined, which found adequate and undistorted reflection in the Truths. Another crucial feature of common law records is that they ground norms, which are obligatory for everyone, at the same time being class society memorials. We are accustomed to approaching the Truths with a certain number of questions: family structure, property, personal and proprietary interests of the representatives of various social categories of the population, changes in their position; these and similar questions are connected with the general issue of the genesis of feudalism. Historians and lawyers study ancient German law, legal proceedings characteristic for it, general judicial principles and certain legal institutes ("old legal customs") on the basis of the Truths. This approach along with its limitations and juridism, is lawful in its own way, it helps to acknowledge the history of law.

Statutory and legal control is generally connected with certain procedures encompassed by it: with actions, gestures, formulae etc. The procedure is equally important with the norm itself. In this context, we can claim extreme formalism or traditional law rituality. Infringements to the established ritual, avoidance of the firmly established procedural pattern micrify the efficacy of legal norms.

During the times of feudalism with the rule of traditions characteristic of it, actual social relationships tended to gain the strength of the immutable law and the halo of antiquity. Non-standardized behaviour, inclination for innovation and reforms are not typical for this society. It was a virtue to steer the steady course of the set patterns, consistently repeat the generally accepted order. The individual had to be confined in unambiguous limits, know exactly how to act in every given case.

It is obvious that coercion of individuals in the middle of the century originated from hierarchical dependence. It is only possible to get the right understanding of the social structure of medieval Europe if account is taken of the "vertical" ties of ruling and subordination as well as "horizontal" corporate ties with characteristic

socio-political control and education. The traditional type of social relations is characterized by numerous features such as undistinguished individuality, personal dependence of the individual in their family, cast or class. The given feature is the assigned (ascriptive) social status and limited social mobility. The abovementioned features imply strict social control mostly through the mechanisms of interpersonal interaction. As the law does not exist without the state, the state is the institutional coercion mechanism, the newly-formed test facility over human activity. Being the enforcement mechanism, it has a penitentiary system and therein the legitimate power for force application is concentrated.

The feudal system is characterized by the system of social dependences, obligations, duties, privileges etc. established in the hierarchy of social statuses. The individual in the traditional society depends on personal identification. Affiliation to a certain collective (community, cast, status, class etc.) distinguishes the individual's place not only on production, but in the society as well which is fixed by traditions, legal norms, morale and often supported by the religion. Within the framework of such a system, feudal exploitation of bonded peasants and other social groups having a lower rank in the class corporate structure was performed.

The principle of the hierarchy becomes a critical value paradigm of the individual consciousness. This paradigm provokes a keen sense of social distance between the representatives of different classes, groups or casts, it is protected and supported by numerous prohibitions, customs, privileges, traditions, religious dogmas, ceremonies, state and legal prohibitions and other regulations as well as violence and slaughters. If the feudal society is primarily characterized by a big percentage of slaves over freemen, i.e. the society, which does not even have laws common for all people let alone common behavioral norms and values, it becomes clear that personal dependence is in the heart of studying the phenomenon of coercion in the given historic period. The vassal was personally liable to

their senior, but they obtained their title from the group depending on their socio-legal category, corporation, and the master must consider this status.

The relationship of the individual and to the corporation was contradictory: while setting certain rather strict limits to the human person development and channeling it into the regulatory direction, the class group fostered reinforcement of self-importance, corporation members' solidarity and consciousness of their equality. This was relative equality only within the group itself. However, it was an integral step towards later development of consciousness of legal equality for all citizens.

Conclusions. On the basis of the research into the phenomenon of coercion in the philosophic and anthropological context of the Middle ages, a conclusion was drawn that the traditional social environment structure was based on the hierarchy and the political life was grounded on interpretations of power with the religious nature. When grounding their values, people in the traditional society appeal to the tradition but not to the practical reasoning.

Traditional societies differ in the series of features, namely: dependence of social life organization on religious and mythological ideas; cyclical development; collectivist nature of the society and the absence of individuality; primary orientation at metaphysical and not instrumental values; authoritarian nature of power; absence of deferred demand, i.e. the ability to produce not for the purpose of vital problems solution, but for the future. Moral values and the mode of behavioral regulation in the medieval formation created the fundamental form of the system of control over the individual behaviour of people in the traditional society.

The coercion mechanism in the traditional society within the philosophic and anthropological concept has a direct correlation with the vertical and horizontal types of coercion, i.e. class and personal identification at the vertical level and relationships, for instance, at the level of communication, relations and education.

References:

1. Лукашенко А. І. Християнський дуалізм і його вплив на формування специфіки політичної сфери повсякденного життя суспільства (I–XI СТ.) [Електронний ресурс] URL: <http://vmv.kyumu.edu.ua/v/p06/lukashen.pdf>
2. Гуревич А. Я. Категории средневековой культуры. – М.: «Искусство», – 1984. – 350 с.
3. Сулонов П. Е. Философские аспекты проблемы правового принуждения [Електронний ресурс] URL: http://adhdportal.com/book_3592.html

4. Тимофеев М. С. Идеи И. А. Ильина о сильном государстве // История государства и права. – 2013. – № 22. – С. 28–31.
5. Кабальський Р. О. Роль і місце примусу у правовій нормативності // Форум права. – 2007. – № 1. – С. 94–98. [Електронний ресурс]. – Режим доступу: URL: <http://www.nbuv.gov.ua/ejournals/FP/2007-1/07kroupn.pdf>

Section 15. Chemistry

*Garayeva Shabnam Hamid gizi,
senior laboratory assistant,
Sumgait State University,
Department of chemistry and methods of its training,
E-mail: shahbnam-1983@mail.ru*

*Shahnazarli Rita Zeynal gizi,
candidate, of Chemistry, leading researcher,
Institute of Polymer Materials of Azerbaijan
National Academy of Sciences,*

*Ramazanov Gafar Abdulali oglu,
doctor, of Chemistry, professor of department
Sumgait State University,
"Petrochemistry and chemical engineering"*

*Guliyev Abasgulu Mamed oglu,
doctor, of Chemistry, professor,
Institute of Polymer Materials of Azerbaijan
National Academy of Sciences,*

*Corresponding member of Azerbaijan
National Academy of Sciences*

SYNTHESIS OF CYCLIC ACETALS OF VINYLOXYCYCLOPROPANES AND PHOTSENSITIVE POLYMERS ON THEIR BASIS

Abstract: The synthesis of cyclic acetals of cyclopropane-containing vinyl ethers has been carried out and their homopolymerization and copolymerization with maleic anhydride in the radical conditions have been carried out. The interrelation between copolymerization process and formation of the complexes of donor-acceptor type between comonomers in the system has been studied. By a method of PMR-spectroscopy the formation of donor-acceptor complexes between comonomers has been revealed. The photosensitivity of the films of the synthesized copolymers has been investigated and it has been shown that it depends on MW, solubility of polymer, nature of functional substituent and a number of other factors.

Keywords: substituted vinyloxycyclopropanes, copolymers with maleic anhydride, donor-acceptor complexes, photosensitivity, negative photoresist.

Introduction

The vinyl ethers have proven themselves as active monomers for preparation of technically valuable materials

with given properties (strength, thermal stability, plasticity, adhesion, etc) from them [1, 16–19]. The copolymers of these monomers with maleic anhydride possess also wide

spectrum of important characteristics and has a large scientific-practical value. Such copolymers are very interesting and attractive macromolecular compounds for their use as a base in making of the photosensitive materials.

It has been known that the polymers, macromolecules of which contain unsaturated or cyclic groups both in main and in side chain, easily pass into three-dimensional net-like structure at their thermal treatment or in action of radiation, electron beam or UV-irradiation on them [2, 606]. They can be also structured with various vinyl monomers in their interaction in the presence of initiator. Therefore, the polymers containing such chemically active groups as vinyl, allyl and also cyclic groups of carbocyclic and epoxide type in macromolecules is proposed to use in making of photoresists of negative type. In addition, the cyclic acetals and their derivatives are widely used in organic synthesis as reagents, semiproducts, initial substance in preparation of biologically active drugs.

Experimental

The IR-spectra of the synthesized monomers and homo- and copolymers prepared from them were taken on apparatus "Cary 630 FTIR" of firm Agilent Technologies (crystal ZnSe). The PMR-spectra were taken on spectrometer "Fourier" (frequency 300MHz) of firm "Bruker" in various solvents, internal standard – hexamethyldisiloxane. The chemical shifts of signals are presented in a scale δ (ppm).

The purity of the synthesized compounds was determined by a method of gas liquid chromatography on chromatograph of mark LKhM-8 MD.

The characteristic viscosities of the polymer products were determined in Ostwald viscosimeter.

The parameters of MWD of homopolymers were determined on highly effective liquid chromatograph "Kovo" (Czech Republic) with refractometric detector. Two columns by size 3.3×150 mm were used, "Separon-SGX" with size of particles 7 mcm and porosity 100\AA served as immobile phase. The calibrating dependence $\lg M$ on V_R was measured in the range of $M = (3-100)10^2$ with use of polyethylene glycol standards, temperature – $20-25^\circ\text{C}$, 1 account – 0.13 ml.

The photostructurization process of the polymers was studied by irradiation of UV-light of the films applied on glass substrates of the polymer solution in methyl ketone or acetone (film thickness 0.4–0.5 mcm) for 5–30 min at room temperature.

The synthesis of monomers 1–4 has been carried out by interaction reactions of 1,1-dichloro-2-vinyloxycyclopropane with corresponding alcohols or glycols [3, 1099–1111].

Synthesis of 1,1-dichloro-2-vinyloxycyclopropane

The aqueous solution of NaOH (66.0 g, 1.65 mol) in constant mixing on dropwise was added to solution containing divinyl ether (210 g, 3.0 mol), chloroform (1.79 g, 1.5 mol) and TEBA-Cl (6.84g, 0.03 mol) in dichloromethane (400 ml). The reaction was carried out at room temperature. Thereafter the reaction mixture was mixed for 12 h. The prepared reaction mixture was firstly washed with water, then with 1M solution of HCl and again with water. The organic layer was separated, dried over anhydrous Na_2SO_4 and the solvent was distilled off. The residue was distilled in low pressure. A yield of the purposeful product (colorless oily substance) was 23%, $T_k = 70^\circ\text{C}/120$ mm.merc.c., ($48^\circ\text{C}/40$ mm merc.c.), $^1\text{H-NMR} - \delta(\text{ppm.}): (\text{CDCl}_3)$ 1.26–1.90 (2H,m), 2.08–2.6 (1H,m), 5.03–5.58 (3H,m), IR – wave number $\nu(\text{cm}^{-1})$: 3060, 2980, 2810, 1630, 1420, 1220, 915, 760, 665 cm^{-1} .

Synthesis of cyclic acetals of vinyloxycyclopropane

Synthesis of 1-vinyloxy-4.7-dioxaspiro-[2, 4]-heptene (1).

The solution of ethylene glycol 4.66 g(0.07 mol) in DMF(20 ml) and then the solution of 10.7g(0.07 mol) of 1,1-dichloro-2-vinyloxycyclopropane in DMF(40 ml) at 0°C constantly mixing on dropwise was added to mixture consisting of 4.08 g(0.17 mol) NaH in DMF(75 ml). Thereafter the reaction mixture was mixed at room temperature for 12h. Then the water (300ml) was slowly added to the reaction mixture. The mixture was extracted with ether (160ml), the organic layer was washed with saturated solution of NaHCO_3 (twice on 350ml), separated, dried by anhydrous Na_2SO_4 , the solvent was distilled off. The residue was distilled under low pressure. A yield of the purposeful product (colorless oil) – 44%, $T_k = 100-102/135$ mm.merc.c., $^1\text{H-NMR} - \delta(\text{ppm}): (\text{CDCl}_3)$ 1.03–1.37(dd), 4.85–4.95(m), 5.44–5.80 (m), 1.68–1.90(m), 3.75–4.20(m).

On analogous methodology by interaction of 1,1-dichloro-2-vinyloxycyclopropane with propane-1,3, butanediol-1.4 and methanol there have been

synthesized 1-vinyloxy-4.8-dioxaspiro-[2.5]-octane (**2**), 1-vinyloxy-4.9-dioxaspiro-[2.6]-nonane (**3**) and 1.1-dimethoxy-2-vinyloxycyclopropane (**4**), respectively.

Radical polymerization of cyclic acetals of vinyloxycyclopropanes

The polymerization of the compounds **1–4** was carried out in one-chamber ampoule in the presence of 2.2'-azo-bis-isobutyronitrile (AIBN), benzoyl peroxide (BP) and di-tertiary butyl peroxide (DTBP) at various temperatures (60, 80 and 120 °C), depending on type used initiator both in solution (benzene or toluene) and in mass. The polymerization duration – 30 hours.

Cationic polymerization of cyclic acetals of vinyloxycyclopropanes

The cationic polymerization of cyclic acetals of vinyloxycyclopropanes was carried out as follows: the so-

lution $\text{BF}_3 \cdot \text{O}(\text{CH}_2\text{CH}_3)_2$ 0.28g (0.002 mol) in 1.0 ml of toluene in constant mixing was added on dropwise to solution 2.84 g (0.02 mol) of vinyloxycyclopropane **1–4** in toluene (10 ml). The mixture was thermostatted at -70°C and mixing was continued for 3h. The polymerization was interrupted introducing small quantity of triethylamine. Then the solution was poured out into methanol, the precipitate was separated, twice reprecipitated from THF to methanol and dried in vacuum at 50°C . The soluble and insoluble products were divided by filtration of solution to THF.

Results and discussion

With the aim of preparation of the linear polymers with side reactive groups we have synthesized the vinyl ethers with functional groups in geminal position at cyclopropane ring.

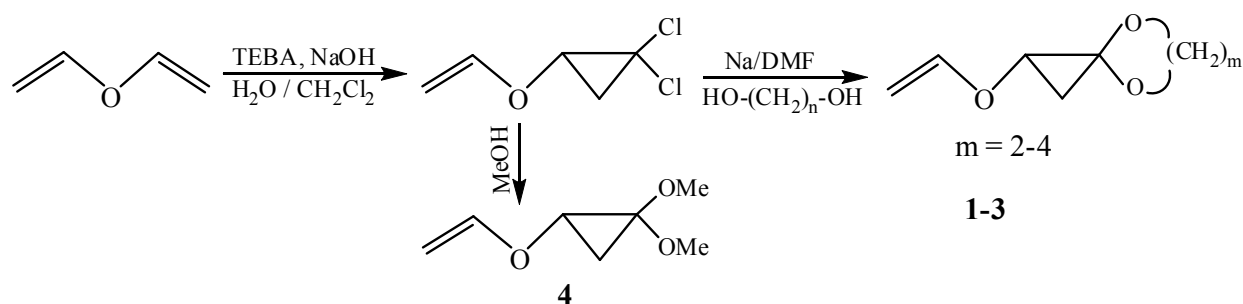

It should be taken into account that the cyclopropane group due to its specific structure gives the electron influence of substituent [4, 223]. The synthesized vinyloxycyclopropyl ethers contain various heterocyclic and non-cyclic substituents at three-membered cycle.

In the IR-spectra of the synthesized compounds there are the absorption bands characteristic for corresponding groups, and the PMR-spectra (Table 1) characterize the proposed structures.

Table 1.– Spectral characteristics of *gem*-disubstituted vinyloxycyclopropanes

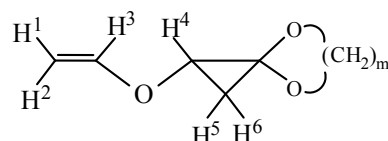

Code of monomer	Chemical shifts of protons and proton-containing groups, δ , ppm							
	H ¹	H ²	H ³	H ⁴	H ⁵	H ⁶	$-\text{OCH}_2, -\text{OCH}_3$	$\text{C}-\text{CH}_2-\text{C}$
1.	4.85	4.95	5.44–5.80	1.68–1.90	1.03	1.37	3.75–4.20	–
2.	4.85	4.97	5.40–5.84	1.86–1.95	1.05	1.39	3.76–4.22	1.82
3.	4.86	5.04	5.45–5.87	1.97–2.25	1.06	1.42	3.88–4.44	1.85
4.	4.82	4.93	5.40–5.74	1.66–1.95	1.06	1.40	3.34–3.72	–

The monomers **1–4**, owing to combination of vinyl group with ether oxygen and cyclopropane ring possess specific properties. A substitution of alkyl group for cyclopropane one having *p*-character in vinyl ether

favors weakening of positive influence of ether group [5, 849–859], as a result of which an inclination of these monomers to polymerization in the conditions of radical initiation is slightly improved.

The results of the model reactions on addition of thiols to vinyloxycyclopropanes in the conditions of radical initiation [6, PK-025] allow to estimate preliminarily the possibility of behavior of the radical

polymerization of the synthesized compounds 1–4 on scheme excluding opening of three-membered cyclopropane ring. The polymerization proceeds only by double bond:

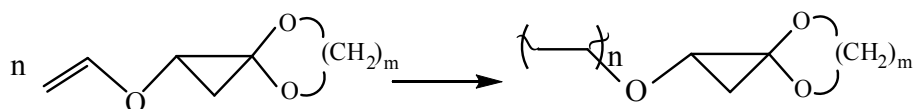

It has been experimentally established that the radical polymerization of the synthesized monomers (conditions and results of polymerization are presented in

Table 2), independently of reaction conditions leads to the formation of oligomers with low MW (degree of polymerization 12–22).

Table 2. – Conditions and results of homopolymerization of vinyloxycyclopropanes 1–4 (solvent – benzene, polymerization duration – 30 h.)

Code of monomers	T, °C	Initiator		Yield of polymer, %		MW
		Type	Quantity, mol. %	Soluble fraction	$[\eta]$, dl/g	
1.	60	AIBN	0.5	42	0.481	2800
	80	BP	0.3	37	0.465	2700
	120	DTBP	0.3	8	–	–
	–70*	BF ₃ ·OEt ₂	0.02	46	0.526	3100
2.	60	AIBN	0.6	38	0.435	2500
3.	60	AIBN	0.6	34	0.356	2000
4.	60	AIBN	0.6	49	0.495	2900

* – the polymerization was carried out for 3h

This is confirmed by viscous characteristics of the prepared polymers and determination their MW by

a method of the high effective liquid chromatography (Figure 1 and Table 2).

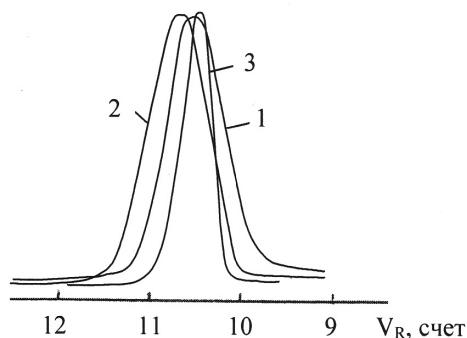

Figure 1. MWD curves of homopolymer of the compounds 1 prepared in the presence of AIBN (1), BP (2) and BF₃·O(C₂H₅)₂ (3)

The comparison of IR-spectra of the synthesized monomers 1–4 and polymers prepared on their basis showed that the absorption bands at 1640–1645 cm⁻¹, characteristic for vinyl group and being in the initial monomers disappear in the polymerization process. The absorption bands characterizing availability of other functional groups and also skeleton vibrations of

cyclopropane ring in this case are kept in the polymer spectrum. The analogous results are prepared in consideration of PMR-spectra of the initial monomers and polymers prepared on their basis. In the PMR-spectra of the polymers two partially overlapping signals with the same intensity are observed. These signals are referred to protons of CH₂-groups of cyclopropane ring ($\delta = 1.54$ ppm)

and protons of CH_2 -groups of the polymer chain ($\delta = 1.9$ ppm). The analogous signals of equal intensity are also appeared for methine protons of three-membered cycle ($\delta = 3.60$ ppm) and protons of CH -groups of the polymer chain ($\delta = 4.12$ ppm). These data confirm that the polymerization of the synthesized monomers proceeds due to opening of only double $\text{C} = \text{C}$ -bond, in this case cyclopropane group with corresponding substituents is kept.

It should be noted that during polymerization in the presence of radical initiators with temperature rise a yield of the polymer is increased. In particular, at temperature rise from 80 to 120 °C a yield of the polymer for 6 h is increased approximately in 3 times. An increase of initiator concentration doesn't lead to the essential increase of a yield of the prepared polymers; a viscosity and MW remain almost at the same level, and in some cases are even decreased. With increase of the polymerization duration a yield of the polymer is increased, but this is not reflected on increase of MW. Relatively high MW is observed in a case of polymerization of monomer **1**.

Thus, in a case of the radical polymerization of monomers **1–4** the process proceeds selectively on

vinyl group with preparation of oligomers of linear structure with side cyclic groups capable for further conversions.

For revealing of dependence between structure of the synthesized compounds **1–4** and their polymerization activity we have carried out the polymerization of these compounds in the same conditions in the benzene solution in the presence of AIBN. It has been found in this case that the monomer **1** show the greatest activity, monomer **3** – the least. With broadening of acetal cycle (with increase of m value) MWs of polymers are slightly decreased (Table 2). The least activity of the monomer **3** has been possibly connected with steric hindrances stipulated by large size of cyclic fragment.

In our further investigations the synthesized cyclic acetals have been included in radical copolymerization with maleic anhydride (MA). Since in the radical conditions of copolymerization each of comonomers of this system almost is not capable for homopolymerization, the chain growth is possible only due to cross-interaction of comonomers, in which it can be participated both free and connected monomers to complexes.

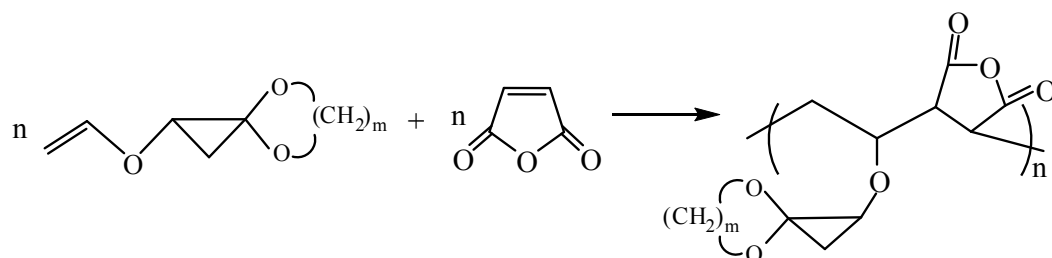

The calculated MW values (taking $K = 4.11 \cdot 10^{-4}$ and $\alpha = 0.89$ [7.2273–2278]) of the copolymers prepared in the various conditions indicate to their relatively low

MW; their characteristic viscosity was changed in the ranges from 0.36 to 0.53 cm^3/g .

Table 3. – Copolymerization of cyclic acetals of vinyloxycyclopropanes **1–3** with maleic anhydride ($[\text{AIBN}] = 0.02$ mmol/l; $T = 70$ °C)

Code of monomer	Composition of the initial mixture, mol.% of monomer	Copolymerization time, min.	Conversion, %	Composition of copolymer, mol% of monomer
1	2	3	4	5
1	90.0	20	8.5	49.9
	70.0	20	10.6	50.0
	50.0	20	15.3	49.8
	30.0	20	12.0	50.1
	10.0	20	9.9	49.8
2	90.0	20	8.3	49.9
	75.0	20	10.2	50.0

1	2	3	4	5
2	50.0	20	14.7	49.7
	25.5	30	11.8	50.1
	10.0	60	9.7	50.2
3	90.0	20	7.9	49.3
	75.0	20	10.1	50.1
	50.0	20	14.4	49.9
	25.5	30	11.5	49.6
	10.0	60	10.1	49.7
4	90.0	20	7.7	50.2
	75.0	20	9.7	48.9
	50.0	20	14.0	50.1
	25.5	30	11.2	49.6
	10.0	60	10.0	49.6

The spectral analysis showed that the copolymers prepared both in mass and in solution is identical on composition, intramolecular distribution of links and chemical structure. It has been established on data of IR-spectroscopy and elemental analysis that the composition of the prepared copolymers practically doesn't depend on ratio of the initial monomers and close to equimolar (Table 3).

As a result of copolymerization of cyclic acetals **1–3** and compounds **4** with maleic anhydride there have been prepared the copolymers insoluble in aromatic hydrocarbons being white or light-yellow powdered products. However, the copolymers were well dissolved in polar organic solvents – in acetone, ethers, DMF, and so that the thin films could be poured from them. The maximum yield of copolymer corresponded to ratio of monomers in the initial mixture 1:1. The method of carrying out of copolymerization (in solution or in mass) shows an insignificant influence on yield of the copolymers.

The IR-spectra of the prepared copolymers showed the availability of the absorption bands in the field of 1780 cm^{-1} , characteristic for carbonyl group of anhydride fragment. An availability of the absorption bands at $1020\text{--}1050\text{ cm}^{-1}$ characterizes the skeleton vibrations of three-membered carbon cycle. At the same time in IR-spectra of copolymers the absorption bands in the field of $1640\text{--}1645\text{ cm}^{-1}$, corresponding to valence vibrations of double C=C-bond are absent. Our experiments showed that there are no essential changes in the IR-spectra of the copolymer prepared at various ratios

of the initial comonomers. All these data allow to conclude that: firstly, in the copolymerization process only double bond of vinylloxycyclopropane (in this case three-membered cycle is not touched) takes part. Secondly, the copolymerization proceeds with participation of both comonomers with formation of the copolymers of equimolar composition, and thirdly, a ratio of comonomers in the initial mixture doesn't influence on composition of the prepared copolymers.

It was known that during copolymerization of the vinyl ethers with electron-acceptor monomers, for ex. MA, the donor-acceptor interaction between comonomers, which extremely increases the polar effect of the reaction arises. In this case, the complex-formation between comonomers in the initial mixture is reflected on characteristic peculiarities of behavior of the copolymerization process [8, 253]. For study of complex-formation process the MR-spectra both pure MA and MA in the presence of comonomers **1–4** in solution CDCl_3 were taken.

As shown by data of PMR-spectroscopy, the chemical shift of protons at double bond MA ($\delta=7.25\text{ ppm}$) in the presence of comonomer of vinylloxycyclopropane undergoes the displacement to more weak field ($\delta=7.13\text{ ppm}$). Such change of the chemical shift of MA protons in the presence of above-listed comonomers has been connected with formation of donor-acceptor complex in the system. In other words, in mixing of comonomers in the initial mixture a charge transfer from donor (vinyl ether) to acceptor (MA), which evidences about

formation of complex between them takes place, and as a result a displacement of the chemical shift of protons at double bond in molecule of MA occurs [9, 398].

The equilibrium constants (K) of the vinyl ethers with MA (Table 4) were determined analogously to methodology presented in work [10, 401–406].

Table 4. Complex-formation constants of cyclic acetals 1–4 with MA (solvent – CDCl_3 , [MA]– 0.03 mol/l [cyclic acetal]–0.65–2.20 mol/l)

Complex	T, °C	K, l/mol
Monomer 1 – MA	25	0.240
	45	0.185
	65	0.150
Monomer 2 – MA	25	0.260
	45	0.200
	65	0.162
Monomer 3 – MA	25	0.280
	45	0.220
	65	0.180
Monomer 4 – MA	25	0.220
	45	0.187
	65	0.160

The investigation of temperature dependence of complex-formation K was studied at various temperatures, which allowed to estimate thermodynamic pa-

rameters of complex-formation on Van-Hoff equation (Table 5) [9, 99–102].

Table 5. – Enthalpy and entropy values at complex-formation of monomers 1–4 with MA

Complex	$-\Delta H$, kcal/mol	$-\Delta S$, e.units
Monomer 1 – MA	1.175	6.06
Monomer 2 – MA	1.183	5.84
Monomer 3 – MA	1.105	5.50
Monomer 4 – MA	0.798	5.44

As follows from data of Table, ΔH values evidence about arising of weak donor-acceptor interactions in the investigated complexes, they almost are not differed and close to the energy of van der Waals interaction energy.

For investigation of photosensitive properties of the prepared copolymers we have carried out the photochemical structurization. The films of the synthesized copolymers poured from solutions and dried at 60 °C, were irradiated with xenon lamp by capacity 2 kWt for 30 min. In this case, we have detected that at irradiation the films are partially lost their solubility. This was clearly observed in comparison of IR-spectra of these copolymers before and after irradiation. The spectral investigations have revealed the decrease of intensity of the absorption bands of cyclopropane and acetal groups at 1030 cm^{-1}

and 1100 cm^{-1} , respectively. It was simultaneously observed the displacement of the absorption band of carbonyl of anhydride group from 765 cm^{-1} to 1780 cm^{-1} without change of its intensity. The change of intensities of the absorption bands after UV-irradiation of the films has been probably connected with formation of “bridge bonds” between macromolecules due to opening of cyclopropane and acetal groups.

The cross-linking process under action of photoirradiation was investigated by immersion of the irradiated films to solvent (acetone) for 3 min. After drying and weighting of the films a quantity of insoluble part of the film has been determined (fig. 2). Since the mass losses of the film depend on degree of its cross-linking, with increase of degree of cross-linking the mass losses fall.

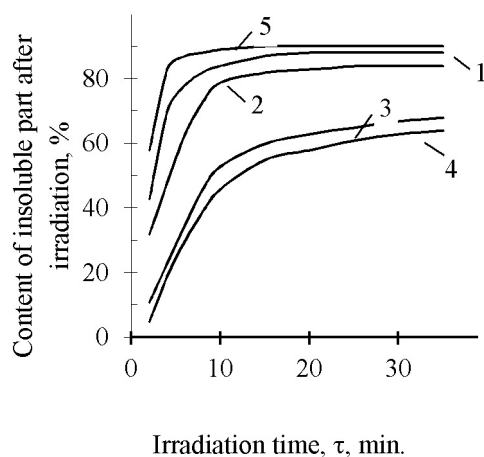

Figure 2. Dependence of mass loss of the copolymer films 1–4 with MA after irradiation on exposition time (5 – in the presence of sensitizer)

The unirradiated sites of the films were completely dissolved in acetone. On increase of irradiation duration (in this case, a degree of cross-linking increased) the film solubility fallen and after 20 min. of irradiation a mass of soluble part was minimal and constant. It has been also established that an addition of approximately of 1.0 benzoin or cobalt-naphenate as sensitizer to the system led to sharp fall of mass loss. In this case, a degree of cross-linking of the copolymer films reached 58–85% already for 2–5 min. This value depended on nature of the functional substituent at cyclopropane fragment, MW, solubility of polymer and a number of other factors.

Conclusions

1. By interaction reaction of dichlorocarbene with divinyl ether it has been synthesized *gem*-disubstituted vinyloxycyclopropane, on the basis of which a number of derivatives of cyclic acetals has been prepared. The homopolymerization of the synthesized substituted vinyloxycyclopropanes in the presence of radical initiators both in mass and in solution has been carried out and it has been shown that in polymerization only vinyl group participates. The composition and structure of the synthesized monomers and polymers prepared on

their basis have been established by data of chemical and spectral analyses.

2. The joint polymerization of the synthesized monomers with maleic anhydride has been carried out and it has been show that the process proceeds with formation of complexes of donor-acceptor type. It has been established that the composition of the prepared copolymers doesn't depend on composition of the initial mixture and in all cases corresponds to equimolar composition of comonomers. The complex-formation constants, the values of which evidence about occurrence of the weak complexes between comonomers have been determined. The temperature dependence of complex-formation has been established and thermodynamic parameters of the process have been calculated.

3. Some properties, including photosensitivity of the prepared polymers have been investigated. It has been established that a content of insoluble part of the copolymers films of cyclic acetals with MA after irradiation depends on exposition time, structure, MW and solubility of the copolymer and also on size of cyclic fragment at cyclopropane ring.

References:

1. Raskulova T. V., Sviridov D. P., Tupota K. V., Antokhina E. Yu. Investigation of strength properties of coatings on the basis of copolymers of vinyl chloride and vinyl ethers // Bulletin of the Angarsk State Technical University.– 2008.– V. 2.– No. 1.
2. Moro U. Microlithography: principles, methods, materials / Trans. from Engl, edited by R. Kh. Timerova.– M.: Mir.– 1990.– 1 p.

3. Sanda F., Takata T., Endo T. Vinylcyclopropane cyclic acetal-synthesis, polymerization structure of the polymer and mechanism of the polymerization // *Macromolecules* – 1994. – V. 27.
4. Yanovskaya L. A., Dombrovskiy V. A., Khusid A. Kh. Cyclopropanes with functional groups. – M.: Nauka. – 1980.
5. Plemenkov V. V. Electronic and spatial structure of multifunctional cyclopropanes // *J. Org. Chem (Russia)*. – 1997. – V. 33. – No. 6.
6. Shahnazarli R. Z. Adducts of thiols with allylcyclopropylmethyl ethers – biocide additions for polyvinyl chloride / 4th International Polymeric Composites Symposium, Exhibition & Brokerage Event “IPC-2015”, Izmir, Turkey, – 2015. (PK-025).
7. Antonovich F. F., Kruglova V. A., Skobeleva N. I. et al. Copolymerization and complex-formation in the system of 2-trichloromethyl-4-methylene-1,3-dioxolane – maleic anhydride // *Vysokomolek. soyed.* – 1980. – V. 12-A. – No. 10.
8. Complex-radical polymerization / V. A. Kabanov, V. P. Zubov, Yu. D. Semchikov. – M.: Khimia. – 1987.
9. Guryanova E. I., Goldstein N. G., Romm I. P. Donor-acceptor bond. – M.: Khimiya. – 1973.
10. Kalinina F. E., Mognonov D. M., Radnayeveva L. D., Vasnev V. A. Alternating copolymers of vinylglycidyl ether of ethylene glycol and imides // *Vysokomolek. soyed. Ser. A.* – 2002. – V. 44. – No. 3.

Section 16. Economy

*Nushaba Hajiyeva,
PhD., associate professor, of Marketing Department,
Azerbaijan Technological University
E-mail: nushaba.hajieva@mail.ru*

*Ismailov Vugar, Ph D.,
associate professor, of Public Administration Department,
Azerbaijan Technological University
E-mail: vismayilov.atu@gmail.com*

CURRENT STATUS AND DEVELOPMENT ASPECTS OF CONSULTANCY SERVICE IN AZERBAIJAN

Abstract: The article states that consulting and consulting services in Azerbaijan have been studied by taking into consideration the fundamental changes in society, including the impact of globalization. Removing visible gaps in this direction significantly updates the study of theoretical and practical aspects of consulting activity. The main goal is to develop theoretical and practical proposals to improve the competitiveness of business organizations and the country in the light of the establishment of a perfect consulting service mechanism by taking into account the new reality of socio-economic development.

Keywords: market economy, consulting, marketing, competitiveness, anti-crisis management, information technology.

The transition to the sustainable development of the Azerbaijani economy has created new business conditions. Sustainability and the rapid expansion of the people's recycling process require knowledge and information from the business world and modern world to rapidly accumulate. Time shows that no economic existence can develop without the exchange of old and new knowledge. For this reason, the main competition in modern trade is for new technological knowledge. Giant foreign companies and local businesses often receive new information from consultants and consultants, including in production management, finance, marketing, sales and other areas [1].

In the market economy, competition between commodity and service providers is at the most competitive level in most markets. When the demand exceeds the bid, it selects the consumer product manufacturer. In the case

of free choice, consumers prefer the product maker based mainly on their specific needs and requirements. For this reason, producers must produce such products in order to be successful in the market and to earn profits in order to meet the consumer's individual needs and criteria. The uncertainties and changes of the consumers are affected by this. In case of uncertainty, consultation with a professional consultant or consulting firm may be more useful [4].

As a result of the joint venture, the consultants' knowledge and experience of the consulting firm will lead to the establishment of a new management system, effective business process management, improved business planning and reporting, and a modern foundation of staffing, marketing, advertising and finance management.

The aforementioned results are the services that consulting firms can sell on the market. For this reason, the improvement of the management and management

system of consulting companies is an important task and its implementation serves the success of the consulting company in the market [3].

The success of a consulting firm depends on the accumulation and management of highly skilled specialists. The analysis shows that most of the highly talented intellectuals in professional organizations do not fit and that competition between them has become even more acute: it is a source of a scientific problem in the local context.

On the other hand, it is preferable to use traditional and simple management decisions for easy and rapid access to local business structures. The prevention also depends on the diversification of consulting activities. From this point of view, the examination of the problems related to the development and development of consultancy activities in the local context is of great scientific and practical importance and therefore urgent.

The main aim of writing the article is to prepare theoretical and practical suggestions to increase the competitiveness of commercial organizations and the country on the basis of establishing an excellent consulting service mechanism, taking into account the new reality of socio-economic development. In this context, it is planned to do the following specific tasks: investigate the theoretical bases of the operational link between the organization's competitiveness and consulting services; analyze and characterize the situation of existing consulting services in the country; determining the market share based on the country's core consulting companies; to evaluate the new aspects of consultancy services in Azerbaijan; describe development trends in consulting services in information technology.

As a result of the researches, for the first time in Azerbaijan, the location and role of outsourced consultancy service for the organization of consultancy services and the effectiveness of separate commercial organizations of the country were determined. The main scientific innovation of the research is as follows: a functional commitment has been established between the competitiveness of local business organizations and consulting services; modern approaches to the development of consulting projects have been clarified; the characteristics of the current situation of the counseling service in the country; market positions were assessed on the basis of key counseling companies in the country; ways to give advice on the implementa-

tion of strategic management elements; the priorities of the consultations in the vital management system have been disclosed; features provided by consulting in the field of information technology; the consultancy services market in Azerbaijan was described as a series of other elements of the modern market economy. Before the reform of the market economy, we did not have consultancy. In the Soviet economy, the organization gave advice through undertakings or other high institutions, ministries and exchanges of advanced experience such as chefs or other businesses. Faced with many new challenges in bringing the market economy and economic decisions to the institutional level, economic leaders have become a major source of demand for management consulting. But it took many years for these requests to become a real (paid) student.

Tough competition in national and global markets requires continual renewal of organizational structures, management systems and methods. In addition, the risk of taking wrong decisions as a result of irregular reforms was very high. Old organizational methods and management concepts did not give the necessary results [5]. Tens of years of experience show that leaders need to be aware of the reliability and availability of consultants, especially in the acquisition of the most up-to-date tools in organizational design through the adoption and adoption of strategic and operative decisions to reduce risks and make major decisions.

In addition, the situation in the consulting market in Azerbaijan in the last decade has been characterized by a large external consultant flow. The reason for this is that the world market is looking at the opportunities of the Azerbaijani market and the demand for counseling services in countries with stable economies. The advantage of large international consulting firms is that they do not compete with companies that encourage this service in the national market. The absence of a management consultant forced western consulting firms to change the way they entered the national market.

Generally, the entrance to the market is carried out by taking over a large domestic company and bringing it together with an international cooperation network after completion. At the beginning of the 1990s, there were no such companies in Azerbaijan, and international consulting firms chose to establish new and full-fledged subsidiaries in their own countries.

Based on the direct investment of foreign consultancy firms in Azerbaijan, the consulting sector has facilitated the use of new methods and standards in services offered to local clients forced to comply with high standards. On the other hand, foreign companies that have entered the market for the first time can communicate with more promising local customers. This leads to a slight delay in the initial development of local consulting firms.

By the end of 1990s there were dozens of local consulting companies in the Azerbaijani market. Some of their relics can be compared to the number of employees in the international consulting network. Foreign experts are generally preferred by customers for the following reasons: international market access for the introduction of goods and services and the attraction of western capital; raising the image of the operator and international reputation; information on western standards for the implementation of our work; receive “first-hand” help provided by them during interaction with foreign workers; The conservatism of the business, that sometimes the leaders of big businesses are not in a hurry to cut off their involvement with foreign consulting firms.

At the same time, western consultants were required to participate in the consulting projects under the auspices of international agencies. However, the share of financing in the income of Western Azerbaijani branches is gradually diminishing.

Foreign consultants in Azerbaijan market faced many difficulties. These include: characteristics of socio-political and economic situation; the psychological characteristics of social-organizational culture; language barrier etc.

The following are the shortcomings of Western consultants’ activities: ignoring the characteristics of the realities of Azerbaijan; insufficient information about local business problems; to turn their Azerbaijani businesses into storage areas to train their employees; efficiency and high price for large businesses only.

A survey was conducted among the 300 entrepreneurship institutions to investigate the need for consultation services for small and medium-sized enterprises in the Republic of Azerbaijan. A survey was conducted on 300 entrepreneurship organizations between 19 April 2012 and 30 May 2012 to examine small and medium-sized entrepreneurship consultancy services covering 8 economic regions in Azerbaijan.

Of respondents, 38%, 0% or 114% said they were providing consulting services in business activities, 62%, 0% or 186 participants said they could not benefit from these services.

25.3% of the respondents or 76 participants did not need these services, 9.0% or 27 participants did not have the opportunity to do this, 8.3% or 6, 3% or 19 participants responded to this question by 25 survey participants did not realize, 3%, 0% or 9 participants were expensive and at the end one or three or four people had no other solution. I think, etc.).

As a result of the research, it was determined that many field consultancy services will develop in Azerbaijan over the next decade.

The global financial crisis of 2008–2009 caused the customers of the trump card companies to increase and the demand for this area increased. This has become a serious problem for the young consulting sector of Azerbaijan. In connection with this, the priorities in the field of audit and consultancy have changed: industry choice for industry; diversification of activity; weakening of competition power with foreign consulting and supervisory firms focusing on activities in Azerbaijan; transfer of the activities of the Baku companies to the regions; reduce the number of consultants’ royalties.

Despite the narrowing of the consulting market in Azerbaijan, they managed to maintain their position as key actors, and they had the ability to maneuver at the expense of a supervisory operation, many of which were less affected by the crisis. In Azerbaijan, the post-crisis dynamics of the consulting industry show the beginning of a new phase in development. For the first time, the dynamic development of this area has been observed on the basis of internal resources without external technical assistance. At that time, new customers entered the market. These were the institutions created or survivors during the crisis and the institutions they needed to acquire additional knowledge and skills (development strategy, organization and implementation of business processes, management accounting, implementation of financial management functions, etc.) in a swift manner. In addition to his education, this was the way to apply to consulting firms that had successful experience in implementing similar projects.

The market was a positive situation in the post-crisis period. However, the market development indicators in

2000 indicate that consulting services increased by 60% and service market by 36%. This means a radical change of situation. Since then, the number of consultants and experts has increased [6]. Many successful and emerging consulting firms have not made enough efforts to revitalize the market of Azerbaijan's consultancy services. Thus, in Azerbaijan there is a genuine consultancy request regarding economic growth. After that, the development of local counseling services became more civilized.

One of the main objectives in the field of counseling is to understand the nature of the antiviral management counseling and what is its key role.

An important role for encyclopedic management consulting is to give the experience of western firms a clearer impression. The majority is based on the current capital situation and the inadequacy of the operating capital. This results in a debt burden [7]. Management consultants are primarily trying to clarify the cause. It should be noted that the consulting firms now improve the client's financial situation and allow the advisor to pay initial costs, including services. The consulting firm analyzes the first stage of the business, diagnoses, analyzes the accumulated debt, and prepares a reduction plan. Negotiate with major lenders. The assessment of the financial situation, the finding of the causes of the debt and the remedial measures allow you to develop the system. In most cases, when the former debt is exempted, it has recovered its profitability and has faced the problem of changing the operation of the business. In this case, it is proposed to reduce taxation the least in the framework of existing legislation. The next step is the reorganization of production and the definition of a new action model. It focuses on the implementation of complex projects that combine complex projects, financial performance and management, audit, tax and accounting matters, legal expertise, the application of modern management and information technology, staff selection and budgeting.

In the client's complex financial position, the consulting firm succeeds in dealing with management issues successfully. Management consultants do not only develop and present a precautionary system to improve the health and financial situation of the enterprise, but also provide a management team that can heal with the help of consultants. Information technology (IT) is increasingly influencing the various areas of our lives, including the economy. There are also two revolutions in devel-

oped countries at the same time: information technology and business. As a result of mutual influence, they contribute to the development of each other. First, under the influence of information technology, an effective business management and a general method of quality have emerged. Then there was a radical job change, such as restructuring business processes, a production process management system, special apparatus and software installation. In addition, this area was chosen more dynamically. Annual growth rate is 7–8%.

Information technology (IT) experts say that information technology is the integration of computers, electronics and communications. It is a set of methods and tools that are used to deliberately alter any information.

There is a functional commitment between the consulting service and the operational efficiency of the operator. The presence of variance variance leads to continuous improvement of the consulting service. Our research suggests the following: normal and efficient working of the economic entrepreneurial issues without the administrative emirate system can not be achieved without consulting services. The production relations in the market economy are based on the creation of legal economic, political, social, economic and technological conditions and the functioning of objective economic laws and consequently the knowledge and experience of the consulting company; building companies can play a role in the market economy by exploring who, what, when and for what purpose they are working:

Firstly, consulting services are a commodity that is offered in accordance with the managers of the business and management uses this assistance when making management decisions;

Secondly, the development and redesign of responsible consultants requires the need for assistance.

Thirdly, when incorporating consultant advisors, the client believes that by expert evaluation of the conditions created by him, new ideas, results of related research, discussion of the problem, and ultimately professional experience will be gained.

Therefore, when the responsible management decisions are taken, it can be concluded that the consultants are involved in the solution of the uncertainty. The project shows that a consultant regards him as a tool to remove uncertainty from the center and that if it develops in this way, it is a success guarantee.

– In order to maintain business continuity and adapt to the changing environment, it is crucial that the organization of the organization and its business be restructured and its behavioral, business strategy and tactics changed. To do this, it is necessary to take advantage of complex measures in the context of tough competition and uncertainty. One of the measures is to include external consultants who allow them to find solutions to the challenges that arise. Uncertainty in governance is an important factor that requires consulting services. The increasing complexity of work is a great explanation of what has emerged in the world of consulting services in the early 21st century.

– As with any other product, the consulting service has its own life cycle: design and development, approval, market access, development, competence, completeness and stagnation stages. This process is also a temporary one. Many services have lost and need to be replaced. Other services are emerging and should be implemented. In the European research book, the list of counseling advisers is grouped as consulting services in 94 groups.

– Establishing relationships without consulting potential customers is one of the ways of marketing consulting services. The link may remember the interest of the consultant and the consultant's name. This kind of communication is very rarely influenced by the taking of the task. However, if the consultant has enough information with a client, he can say that the client is a problem and that he has taken the necessary suggestions.

– In the last decade the situation of the consulting market in Azerbaijan has been characterized by the flow of foreign consultants due to the request for consulting services in the countries with stable economies as well as the demand for the world market to explore the opportunities of Azerbaijan market. The advantage of large international consulting firms is that they do not compete with companies that perform their services in the national market. The absence of a management consultant forced western consulting firms to change the way they entered the national market [8]. Generally, the entrance to the market is carried out by taking over a large domestic company and bringing it together with an international cooperation network after completion. At the beginning of the 90s there was no such company in Azerbaijan and international consulting companies led

to the establishment of new and fully managed branches by subsidiaries in developed countries.

– As in the whole world, the main topic of consultancy in Azerbaijan is accounting and auditing. Adding local experts to the preparation of projects in Azerbaijan (about 60%) and giving them their brands. It is the initiative of these companies to coordinate local and world experience and to create conditions that will benefit their local customers. Thus, it is obvious that the quality of service will gradually compress the western professions that have reached the global level from local markets.

– Twenty of the 50 major consulting organizations operating in our country are working on legal grounds, with the largest circulation between Nazal Consulting LLC and the British Consulting Group LLC. One of the counseling firms operates in the field of "Accounting and Tax Counseling". Among the various companies belong to a foreign investor and "EA Consulting" LLC, which owns the Caspian Accounting. However, 42.7% (13277, 5 * 100 / 31119.25) of the total consulting market in the country belongs to Ernst & Young Holdings (Bioscience) Bi. Vi's branch in Azerbaijan.

– The global financial crisis of 2008–2009 has reduced the ability of customers and consulting firms to meet this demand, which is a serious challenge for the young consulting sector in Azerbaijan: there has been a change in the priorities of supervision and consultancy in this context: industry choice for industry; diversification of activity; weakening of competition power with foreign consulting and supervisory firms focusing on activities in Azerbaijan; transfer of the activities of the Baku companies to the regions; Reducing the number of consultants.

The competitive activities of the leaders who provide consultancy services in Azerbaijan are linked to the following factors: the presence of local businesses with potential customers; occupational level of trainees; information about local characteristics and psychology of local customers; financial support provided by prestigious institutions; mastering advanced business technologies; price policy; it is important that the consultant has a competitive advantage or development. If it is possible to reach the target without paying much attention to it, it should establish its own strategy and be informed of its current and future clients. Of course, not every consultant can gain local or international reputation in their field.

There are many possibilities, so many consultants can offer special services to their clients.

Implementation demonstrates that consultants must have access to reliable information to help them deal effectively with financial difficulties. The development of

the rescue plan is only possible under these circumstances. However, it is often the first explicit statement. As you know, any company can not systematically follow the current situation in the market or continue its operations. The most effective expression in case analysis is diagnosis.

References:

1. Ivanov M., Ferbel M. Guide to the marketing of consulting services. The publishing house "Alpina Publisher", – 2003.
2. Humbataliyeva S.A "History of management consulting." Questions of economic sciences.– Moscow – 2009.– No. 5.– P. 126.– 128.
3. Peter Blok Perfect Marketing Publishing, Peter, – 2007.
4. Mel Zilberman Consulting. Methodes and technologies. Publishing House, Peter – 2007.
5. Kurbatova O. V. Development of the market of consulting services, Unity Dona Publishing House, – 2005.
6. Abbasov S.A. "The role of consulting services in the anti-crisis management system". Revival XXI century, – 149–150.– 2010.– P. 348–355.
7. Shiffen S. Guidance Consultant, Publishing house «Pippo» – 2004.

*Petanaj Migena,
Ph D., University "Ismail Qemali" Vlorë, Albania
Department of Finance
E-mail: migenapetanaj@hotmail.com*

*Durmishi Veronika,
Ph D., University College "Pavarësia" Vlorë, Albania
Dean Faculty of Economics and Social Sciences
E-mail: veronika_durmishi@Yahoo.com*

THE EFFECT OF TAX REDUCTION IN TOURISM AND THE DEVELOPMENT TRENDS OF THIS SECTOR IN ALBANIA

Abstract: Tourism today is one of the largest industries in the world, creating more jobs than most other sectors. The sites that are in the early stages of tourism development, such as Albania, have the potential to benefit from tourism, especially in the reduction poverty and economic growth. The main purpose of this paper is to show that the government with the new fiscal package for tax reduction in tourism contributes to the sustainable development of this sector and to the full formalization of the tourism sector as a strategic sector for the country's economy.

Keywords: tourism economics, fiscal packages, tax reduction, tourism sector formalization, tourism investment.

Introduction

After the 2000s, our country is making many efforts to master a stable political and economic situation, but still in the country there are conflicts and very important issues to be resolved. There are already premises for a diverse tourism development not only in group but also individual and family organization. Also in the programs of political parties and governments, the development of tourism development plans as the primary development branch in the country is central to the country. To achieve a higher development, stronger co-operation between central and local government is needed, but not there remain also individuals who deal with this field. Tourism would not be considered as an important economic sector, but as an ideological sector, which would limit both qualitative and quantitative aspects [1].

Tax reduction in tourism, a factor determining the full formalization of this sector

The Law on Tourism and the Government Program 2015–2020 present clear priorities for the development and promotion of tourism as well as for the improvement of infrastructure, development and promotion of rural and mountain tourism. Existing law, despite attempts to give definitions in the field of tourism, had deficiencies

in their content and lacked important definitions in the field of tourism. Also, the existing law did not clearly provide for the division of competencies of the respective institutions in the field of tourism and, many cases, there were overlapping or ambiguity about them. The current law on tourism did not foresee the licensing of tour operators, which resulted in a poor and standardized service to the detriment of the consumer and, at the same time, significantly influenced the increase of informality. Also, the current tourism law did not foresee categorizing and classifying accommodation structures. The absence of this process has brought a chaotic situation to the hotel market. Accommodation facilities use distinction marks (stars) that do not conform to the real standards of the structure or the level of service they provide. The Albanian government approved the Draft Law on the Reduction of Value Added Tax (VAT) for accommodation structures in tourism, from 20% to 6%. This bill aims to promote the development of the tourism sector, increase competition and economic development [6].

In the European Union Directive no. 2006/112 / EC "On the Common System of Value Added Tax", in Annex 3, defines what are the areas under which reduced VAT rates can be applied. Thus, this Annex stipulates that one

from areas where reduced VAT can be applied is accommodation at the hotel and other similar services. The directive stipulates that the minimum VAT reduced rate is 5% [3]. Currently, 22 EU member states apply a reduced VAT rate for hotel accommodation and 20 of them apply a rate of less than 10%. Four-star and five-star hotels will not pay a profit tax for a 10-year period if manage to benefit from special status. The effects of the exclusion begin at the moment of the economic activity of the accommodation structure, but no later than three years from the receipt of the special status. The growing contribution of the tourism sector to income and employment in the last three years, culminating in 2016 with 1.5 billion Euros of revenue in the state budget, is one of the main reasons for which the Albanian government undertook the initiative to promote the sector, aiming not only to further increase it through the promotion of investments, but also the formalization and increase of tourism VAT revenues. Reducing VAT in the tourism sector brings us to competitive levels across the region, but also with the philosophy of the countries with a strong tourism-based economy, in support of this sector, with a VAT lower than VAT, is traditional and it happens in all the countries of the region, in Greece, Montenegro, Croatia, and Italy and France. Macedonia applies a 5% VAT tariff, Serbia 10%, Montenegro 7%, Greece 6.5%, Kosovo applies reduced VAT tariffs, so it was time for Albania to apply a reduced tariff in the sector tourism [2]. Reducing VAT on tourism will not have a negative effect on the income of this sector but will expand the tax base in tourism. Reducing VAT directly stimulates the development of a country's strategic sectors. Reduced VAT encourages consumption and because of the size growth of the economy does not affect the budget revenues.

Tourism Development Trends in Albania

Albania is recognized as a safe tourist destination of great value, characterized by a unique diversity of natural and cultural places of the world that are within a relatively small geographic area, which is managed in an environmentally responsible manner and social, which is easily accessible from European tourist markets. The development of tourism in Albania relies on the principles of sustainability. Sustainable tourism is defined as: Tourism that fully takes into account current and future impacts in the economic, social and environmental spheres, addressing the needs of visitors, industry, the environment

and host communities. The development of sustainable tourism is undergoing continuous and requires constant monitoring of the results, taking necessary preventive or corrective action when necessary. Over the past few decades, Albania has conducted a disoriented, aggressive tourism and a short period of just two months and this short-term race pushes hotels not to pay taxes and hide profits. Albania has currently declared only 68 thousand beds, as much as Macedonia, but the rest is not declared. Homes and villas that are issued for tourism have left the state out of control, but now a reassessment of the real situation of tourism is being made. In the countries of the region tourism gives 10–20 percent of annual national production, while in Albania it is up to 6 percent. This is pushing the government to make the teaching and standardization of tourist facilities. Meanwhile, tourist packages are re-evaluating Albania, utilizing the country's transit route to different countries.

According to official data, the highest number of foreign nationals entering Albania in June 2017 results from Kosovo with 31.0%, followed by foreigners from Macedonia with 12.1%, Greece with 9.2% and Italy 7.5%. The entry of foreign citizens month after month recognizes an increase in Albania and ground routes constitute the greatest share of the passenger movement. According to the data of the Albanian Institute of Statistics only in June 2017, road entry occupied 76.9% of the total weight of the movement while the airway inflows reached 14.7% and the seas amounted to 8.4%. The number of foreign visitors entering Albania for holiday purposes and daily visits in June 2017 was 207,972, while in June 2016 this number was 182,606 with an increase of about 13.9% in 2017. [4] The heavy traffic on the streets the country has also increased the risk of road accidents. Regional co-operation within the Berlin process, peace, stability in the region and reforms have spurred the development of tourism in recent years. In Albania, tourism entered this year with a contribution of 7% to Gross Domestic Product and employment of 24% of total labor force in Albania. Albania, according to the World Trade Tourism Center, is now ranked 4th in the world for the level of employment in the tourism sector. Only last year Albania visited more than 4 million and 700 thousand tourists, which represents an increase of 15% compared to the previous year. Last year's tourism brought the economy 1.5 billion Euros in revenue, an increase of 38% compared to 2013 and 13% compared to 2015 [4].

Tourism development trends in Western Balkan countries

At a time when world tourism has developed for decades, the attention of many vacationers has attracted curiosity to the new tourist destination of the Western Balkans. Tourism has been identified as one of the most important sectors in the economic development of the Western Balkan countries, (Bosnia and Herzegovina, Kosovo, Montenegro, Macedonia, Serbia and Albania) and its development strategies lie at the top of the priorities of the respective governments. Through the growth of tourism it is possible to expand the labor market and increase the level of living. Economic growth remains one of the basic criteria within the common goal of the region for integration into the European Union. The Balkans out of wars is now in peace and security and has a unique chance to show the world an uncharted region that thinks to have a common development towards the EU. Thanks to the Berlin Process, the entire region has been included in what is called the Balkan Liaison Project, where we aim to open trade borders, road borders and energy to foster economic development. At the Sarajevo Summit 2017, the Western Balkan countries signed a pact for the creation of a joint regional market including the tourism sector. We are trying to concretize the projects and ideas of the Berlin Process presented at the Vienna Summit in Paris and prepare for the Summit of Trieste – in July of this year. We intend to increase cooperation to increase and diversify regional tourism products, emerging in the global market of global tourism as a common market.

Currently we have two Balkan tourist products: Via Ignatius and Via Dynamical, which connect Western Balkan countries to a single tour. There are also GIZ's projects to build what is called the "Balkan Peak" that moves between three countries, Albania-Kosovo-Montenegro. Many tour operators in the region offer tour packages that include several states: Kosovo, Macedonia, Montenegro and Albania "No one from Asia and mostly from Japan does not come from so far in the Balkans to visit a single country. But comes if you visit the whole region

offering touristic packages along the coast of Albania, UNESCO protected towns, the mountains of Montenegro, the tourist attractions of Serbia etc. At the tourism fair in Tokyo, they will present joint tourism products as a single regional market: Albania, Macedonia, Montenegro, Serbia, Bosnia and Herzegovina [5].

Conclusions

Tourism would not be considered as an important economic sector, but as an ideological sector, which would limit both qualitative and quantitative aspects. Albania is almost 70% untouched and the fact that no hotels and resorts are being built indicates that it is a penalized industry, for the sole reason that it is a risky industry. Mostly the tourist industry, almost 70% of the investments are hotels and resorts and these are investments that have a risk, and the risk is political and economic. Tourism investments have a very large depreciation: they have very long self-sufficiency and certainly will stimulate the state, stimulating those who invest in this sector. One of the main problems is the problem of land ownership that hinders important tourism investments. Tax reduction in tourism will bring revenue growth and formalization of this sector to the country's economy.

Recommendations

The public sector at central and local level should find the opportunities for private initiatives for tourism development to provide financial and institutional support. The private sector should be more organized and increase its impacts on the public sector, in order to increase institutional support through the development of strategic documents for sustainable tourism development. The private sector is not enough to focus solely on capacity expansion, but investments should also focus on the development of human resources and the provision of an attractive touristic offer for tourists. Local community should be an integral part in important decision-making processes for tourism development. The local community, through cooperation with the public and private sector, should make its contribution to the development of sustainable tourism.

References:

1. UNDP, REC: Regional Development Strategy, Millennium Development Goals – 2005 a.
2. Zak Topuzi "World Today", August – 2015.
3. Holland J.'Consensus and Conflict: The Socioeconomic Challenge facing Sustainable Tourism Development in Southern Albania', in Journal of Sustainable Tourism, 8 (6).– 20005.– P. 10–524.

4. Institute of Statistics, Albania.
5. The World Travel and Tourism Council.
6. Ministry of Finance, Albania.

*Huseynli Javid,
Ph.D., candidate,
Charles University, SOCAR
E-mail: huseynoff@live.com*

CORPORATE SOCIAL RESPONSIBILITY (CSR): GLOBAL CAPABILITY

Abstract: The paper reviews the capabilities of companies around the world regarding to Corporate Social Responsibility and its relation to sustainable development. In the first section of the text key findings are being presented regarding the recent development in the field of CSR and sustainability by sectors and the countries. Additionally, the paper mentions that GRI principles, UN Global Compact standards are being mandatory guideline for companies to adopt CSR and increase the awareness on sustainability. Lastly, the paper discusses the modern developments of CSR and lists the areas that can be identified within the national strategy for the development of CSR companies in globally.

Keywords: CSR, sustainable development, strategy, principles, relations, SDG.

Introduction

With the development of the world economy, an increasing number of companies are adopting in corporate strategy vector of socially responsible business. It is this vector of development becomes a fundamental element in the process of strengthening the company's competitive position on the world stage. This practice was embodied in the activities of global companies in recent years, the management of which is aimed at introducing a socially responsible component in various activities in order to strengthen its competitive advantages in both domestic and international markets.

Corporate social responsibility is a complex of measures aimed at achieving sustainable development of both the company and all parties co-operating with it in the course of its activities. Over the past few decades, the business has done a significant leap in the awareness of their own responsibilities with regard to environmental conservation, solving social and economic problems, improve the quality of life of local communities, human rights, anti-corruption, and other problems, the importance of which is recognized by society. As a result, corporate social responsibility is becoming a new business philosophy, according to which the companies are guided in their work not only for profit, but also to achieve the public good and maintaining ecological stability.

Key findings:

By the beginning of the XXI century, most major Western companies have formed their own CSR poli-

cies, and actively develop them at the moment. In 2017 KPMG report study involved 4900 companies from 49 countries and 16 different industries (N100 Group and G250) [1]. It is important to mention that since 1993 the number of reporters have been in upward trend. The results of the study confirm the fact that large companies are increasingly reporting on sustainable development. the highest rates are traditionally show European companies for many years engaged in the preparation of sustainability reports. At the same time companies from the countries of Asia-Pacific region, North and South America, the Middle East and Africa are catching up steadily [2]. Therefore, it is important to highlight that the company's commitment to report on the activities in the field of sustainable development depends on its organizational and legal status.

In the 21st century the growing importance of factors such as innovation and the acquisition of new knowledge establishes the bases of sustainability report. Consumer facing sectors such as the utility, automotive, retail and technology companies in the field of sustainable development reporting have high percent of willingness; other sectors such as oil and gas, industrials and financial the percentage of companies' willingness to report is low [3]. The importance in sustainability reporting is the quality of the information and its reliability, such as business activities should match with the internal environment of the company. Germany, France, UK, Japan and US are willing to report on SDGs and 40 percent

of largest companies in the world (G250 group of companies) discuss the SDGs in their corporate reporting [3]. Investment RobecoSAM, dealing with issues of responsible investing, has published the results of the annual international research *The Sustainability Yearbook 2018* according to which in 2017 the leaders in the field of sustainable development were the European with 40 gold medals, Asia Pacific with 14, North America with 8 and Emerging markets with 11 companies [4]. The first places are awarded to companies that demonstrate the best results in its sector.

To date, the companies scale is used in accordance to GRI principles of sustainable development, which are de facto treated as a single international standard for the preparation of such statements. Without a doubt, this idea of the GRI principles established itself almost in all countries of the world [6]. Major initiatives for sustainable development on a global scale is recognized by the UN Global Compact, as evidenced by the annual increase in the number of companies that have adopted a commitment to comply with the ten principles of the Treaty. Most of the companies that have signed the Global Compact, however, currently 31 companies around the world is reporting on SDGs, mostly the European companies are majority [6].

It is realizable that modern development of CSR more and more has to do with the promotion of socio-environmental responsibility through a chain of suppliers and subcontractors of the company, thus this process is reflected in the additional requirements to stakeholders interacting with companies implement in their work the concept of sustainable business development. These additional requirements could include the following elements: quality of supplied products, security and non-discrimination in the workplace, the greening of production processes and transparency of reporting [7]. Furthermore, the world's major companies often use an integrated reporting that includes elements of financial and non-financial reporting. This type of reporting allows for a comprehensive assessment of company perfor-

mance. Global ecosystem change is forcing big businesses to invest in environmental protection, and the growing number of companies in recent years shifting from the eco-efficiency policies to ecological innovations policy, designed to reduce the amount of consumed resources, primarily energy, and make drastic revolution in itself technological process [8].

Conclusions

The studies show that the companies are showing an upward trend in the field of CSR. The following areas can be identified within the national strategy for the development of CSR companies in globally. **Development of sectoral and cross-sectoral partnerships and initiatives:** This practice can help to representatives of the private sector to overcome the barrier of mistrust on the part of different groups of stakeholders, and united with their business partners, non-governmental organizations, investors, introduce the practice of CSR in the internal structure of their businesses; **Forming a triangle "business-government-society":** become a multilateral Board to develop options for a national CSR strategy; **Providing CSR qualified consulting services interested business representatives:** Pioneering company in the development of CSR rebuilt their own social responsibility strategy and are actively using industry tools, such as special programs, cross-sector partnership, discussion meetings with stakeholders, CSR reporting, the creation of innovative products and services of social or environmental orientation; **Changes in the education system and improving the quality of human:** Internal development programs, corporate universities, cooperation with schools and universities, training programs and jobs with the new requirements raise the general level of competence of people in the country, to create a market and country experts from top management to the workers; **Improving transparency of business:** The active position on CSR will enhance the transparency of the business, thus the company will be able to find out information on the corporate governance structure to the understanding of CSR strategies and social investments companies.

References:

1. KPMG. (2017). *The Road Ahead: KPMG's Survey of Corporate Responsibility Reporting – 2017*. [online] Available at: URL: https://home.kpmg.com/content/dam/kpmg/nz/pdf/November/KPMG_NZ_Survey_of_Corporate_Responsibility_Reporting_2017.pdf [Accessed 19 Apr. 2018].

2. KPMG. (2017). The Road Ahead: KPMG's Survey of Corporate Responsibility Reporting – 2017. [online] Available at: URL: https://home.kpmg.com/content/dam/kpmg/nz/pdf/November/KPMG_NZ_Survey_of_Corporate_Responsibility_Reporting_2017.pdf [Accessed 19 Apr. 2018].
3. Assets. KPMG. (2018). How to report on the SDGs. [online] Available at: URL: <https://assets.kpmg.com/content/dam/kpmg/cl/pdf/2018-02-kpmg-chile-advisory-sustainability-sdg.pdf> [Accessed 19 Apr. 2018].
4. RobecoSAM. (2018). The Sustainability Yearbook 2018. [online] Available at: URL: http://www.robecosam.com/images/RobecoSAM_Sustainability_Yearbook_2018.pdf [Accessed 20 Apr. 2018].
5. Tarquinio L. (2018). An Investigation of Global Reporting Initiative Performance Indicators in Corporate Sustainability Reports: Greek, Italian and Spanish Evidence. MDPI, [online] 10(897). Available at: URL: <http://file:///C:/Users/e04125718/Downloads/sustainability-10-00897.pdf> [Accessed 20 Apr. – 2018].
6. Unglobalcompact.org. (2018). The Ten Principles | UN Global Compact. [online] Available at: URL: <https://www.unglobalcompact.org/what-is-gc/mission/principles> [Accessed 19 Apr. – 2018].
7. Iisd. (2007). Corporate Social Responsibility An Implementation Guide for Business. [online] Available at: URL: https://www.iisd.org/sites/default/files/publications/csr_guide.pdf [Accessed 19 Apr. – 2018].
8. Kemps R. (2018). Ten themes for eco-innovation policies in Europe. [online] Journals.openedition. Available at: URL: <https://journals.openedition.org/sapiens/1169> [Accessed 20 Apr. – s2018]

Contents

Section 1. Biology	3
<i>Aliyev Bahman Musa oglu, Qabilov Malik Yusif oglu, Aliyeva İlaha Fizuli qızı</i> FEATURES OF THE STRUCTURE OF THE <i>CASTANEA SATIVA</i> MILL	3
<i>Alimjanova Kholishxon Alimjanovna, Soatov Giyasiddin Turdiyevich</i> COMPARATIVE STUDY ON DISTRIBUTION OF BACILLARIOPHYTA, CYANOPHYTA, CHLOROPHYTA AND EUGLENOPHYTA ALONG THE STREAM OF KASHKADARYA RIVER (UZBEKISTAN)	7
<i>Ergasheva Olimaxon Xaliqjonovna, Gafurova Lazizakhon Akramovna, Djalilova Gulnora Tulkunovna</i> DISTINCTIVE FEATURES OF THE DISTRIBUTION OF MEDIUM HIGH MOUNTAIN SOILS AND THEIR DEGREE OF ERODIBILITY	18
<i>Dusimbetov Bakhodir Olimbaevich,</i> ANALYSIS OF INTRASPECIFIC STRUCTURE OF ASSOCIATIONS OF SHALLOW MAMMALS OF SOUTHERN ARAL SEA AREA	22
<i>Jumaev Rasul Axmatovich, Sabirov Sobir Karimbaevich, Juraeva Nozimaxon Boxodirxon Qizi, Bolqiboev Shoxrux Shavkat O'g'li,</i> BIOECOLOGY OF GENERATIONS OF TRICHOGRAMMA DILUTED BY DIFFERENT METHODS	25
<i>Saidov Istam Rustamovich, Khimsanbaev Xojimurod Xamrakulovich, Rustamov Atxam Axmatovich, Joxongirov Nozimxon, Jumaev Rasul Axmatovich</i> BIOECOLOGY, HARM OF TOBACCO TRIPS FOR THE COTTON PLANT AND MEASURE OF COUNTERACTION.....	29
<i>Izzatullaev Z. I., Kudratov Z. A.</i> SPECIES COMPOSITION, ORIGIN AND ECONOMIC SIGNIFICANCE OF GASTROPODS (MOLLUSCA, GASTROPODA) OF THE NURATA MOUNTAIN RANGE (UZBEKISTAN).....	32
<i>Imomov Otabek Normirzoyevich</i> BIOLOGICAL AND ECOLOGICAL FEATURES OF <i>ARTEMISIA SOGDIANA</i> BGE IN THE CONDITIONS OF CHUST – PAP STEPPES IN FERGHANA VALLEY	36
<i>Ismatova Zulaykho Asadovna</i> SYSTEMATIC ANALYSIS OF INDICATOR SABORBINE SPECIES OF ALCOHOLS OF THE SANGZAR RIVER	39
<i>Dolimova Surayyo Nugmanovna, Umarova Gulbahor Bozorboyevna, Mukhamadzhonova Guzal Mukhamadzhonovna, Kuziev Sherali Nasrullayevich, Yunusova Muslima Kholmatovna</i> INFLUENCE OF SUPRAMOLECULAR COMPLEXES, SYNTHESIZED ON THE BASIS OF NATURAL COMPOUNDS ON THE MITOCHONDRIAL ENZYMES IN RATS OF VARIOUS AGES.....	43
<i>Mirkhamidova Parida, Khujanazarov Uktam Eshtemirovich, Mamatqulov Doniyor Anvarovich, Ziyamukhamedova Sabohat, Mukhamedov Gofurjon Isroilovich</i> A DETERMINATION OF THE AMOUNT OF VITAMIN C IN SOME MEDICAL PLANTS GROWING IN THE SOUTH– WESTERN ZARAFSHAN MOUNTAIN RANGES.....	48

<i>Niyazmetov Bahodir Allaberganovich, Abdullaev Gaffurjon Rakhimjonovich, Babadjanova Sayyora Khushnutovna, Almatov Karim Tajibayevich</i>	
REGULATION OF THE ENERGETIC FUNCTION AND REACTIVE OXYGEN SPECIES FORMATION IN MITOCHONDRIA BY DAIDZIN.....	50
<i>Niyazova Oybakhor</i>	
THE INFLUENCE OF THE CHEMICAL COMPOSITION OF THE SOIL OF THE ORCHARDS TO THE MACRO FAUNA.....	55
<i>Rzaev Rakhat Muratbaevich</i>	
THE STUDY OF HEART RATE CHARACTERISTICS IN THE POPULATION IN THE CONDITIONS OF KARAKALPAKSTAN	59
<i>Ryabceva Yulia Sergeevna</i>	
THE EFFICIENCY OF <i>BOMBUS TERRESTRIS</i> (INSECTA: APIDAE) AS POLLINATORS OF SWEET CHERRIES IN UKRAINE	61
<i>Seytkamalov Khayratdin Maulenovich</i>	
COMPARATIVE ANALYSIS OF CARDIAC ACTIVITY OF CATTLE IN THE CONDITIONS OF SOUTHERN ARAL SEA AREA	68
<i>Khusanov Tokhir, Davranov Qodirjan, Vakhobov Abdurasul</i>	
EFFECT OF ALFALFA MOSAIC VIRUS ON THE CONTENT OF MICRO AND MACROELEMENTS IN ALFALFA PLANTS IN UZBEKISTAN	71
<i>Sharipov Odiljon Bafoevich, Gafurova Lazizakhon Akramovna</i>	
BIOLOGICAL ACTIVITY OF IRRIGATED GRASSLAND ALLUVIAL SOILS OF THE BUKHARA OASIS	76
<i>Yusupova Umida Rakhmanovna, Botirov Erkin Khojiakbarovich, Mamatova Zulaykho Aminjanovna, Khushbaktova Zaynab, Djabbarova Gulchehra Muhamed-Karimovna, Almatov Karim Tajibayevich</i>	
INFLUENCE OF HAPLOGENIN – 7 – GLYCOSIDE ON RESPIRATION AND OXIDATIVE PHOSPHORYLATION OF RAT LIVER MITOCHONDRIA	80
Section 2. Geography.....	86
<i>Isakova Aziza Yadgarovna, Trafimov Gennadiy Nikolaevich</i>	
ESTIMATION EMPIRIC SUPPLY OF MAXIMUM FLOWS OF MUD FLOODS ON SMALL RIVERS IN UZBEKISTAN	86
<i>Reimov M. P., Húska D., Pulatov A. S.</i>	
CERTAIN ASPECTS OF ECOSYSTEM SERVICE ANALYSIS IN PROTECTED AREAS (RESERVES) OF ARAL SEA REGION IN UZBEKISTAN.....	91
<i>Turgunov Daniyar Mannapjanovich, Khikmatov Fazliddin Khikmatovich</i>	
ESTIMATION OF THE LOW-WATER NORM IN THE MOUNTAIN RIVERS OF CENTRAL ASIA.....	101
<i>Sharipov Shavkat Mukhamadjanovich</i>	
THE EXTENT OF DESTRUCTION OF LANDSCAPES IN THE TASHKENT REGION.....	106
<i>Egamberdiev Khamrakul Tursunkulovich, Petrov Yuriy Vasilovich</i>	
THE TECHNIQUE FOR CALCULATION OF THE NORMALIZED FACTOR OF THE DIRECT SOLAR RADIATION WEAKENING	112

Section 3. Journalism	116
<i>Alimova Gulnoza Bakhshiloevna</i>	
SPECIAL FEATURES OF JOURNALISM IN SOCIAL SITES. PERFORMING LANGUAGE AND STYLE OF TEXT DELIVERY	116
Section 4. Computer science	120
<i>Khujaev Otabek Kadambayevich</i>	
SELECTION OF ARCHITECTURE AND TRAINING ALGORITHMS OF NEURAL NETWORKS FOR CLASSIFICATION TASK SOLUTIONS	120
Section 5. Mathematics	125
<i>Stepanov Vasily Innokentievich, Ni Mingkang</i>	
SECOND ORDER QUASI-LINEAR SINGULAR PERTURBED PROBLEM WITH NEUMANN BOUNDARY CONDITIONS AND DISCONTINUOUS TERM	125
Section 6. Materials Science	130
<i>Ziyamukhamedova Umida Alijanovna, Bakirov Lutfillo Yuldoshaliyevich, Miradullaeva Gavkhar Bakpulatovna, Bektemirov Begali Shukhrat ugli</i>	
SOME SCIENTIFIC AND TECHNOLOGICAL PRINCIPLES OF DEVELOPMENT OF COMPOSITE POLYMER MATERIALS AND COATINGS OF THEM FORCOTTON MACHINE	130
Section 7. Medicine	136
<i>Astanakulova Munisa Mirzoyevna, Bekjanova Olga Esenovna</i>	
THE ROLE OF CYTOKINES IN THE PATHOGENESIS OF EXFOLIATIVE HEALTY	136
<i>Babamuradova Z. B., Shodikulova G. Z., Mirzaev O. V.</i>	
TREATMENT OF PATIENTS WITH UNDIFFERENTIATED CONNECTIVE TISSUE DYSPLASIA IN MITRAL VALVE PROLAPSE WITH VARYING DEGREES OF MITRAL REGURGITATION	140
<i>Bakhritdinova Fazilat Arifovna, Bilalov Bakhodir Erkinovich</i>	
PREVENTION OF EXCESSIVE SCARRING IN TERMINAL GLAUCOMA	144
<i>Bekjanova Olga Esenovna, Rizaev Elyor Alimdjonovich</i>	
PREVALENCE AND INTENSITY OF TEETH CARIES AT THE CHILDREN SICK WITH THE HERPETIC STOMATITIS	148
<i>Ivanov Andrey Nikolayevich, Alekseeva Irina Borisovna, Tankovsky Vladimir Eduardovich,</i>	
TACTICS OF YAG-LASER VITREOLYSIS FOR 20 YEARS	152
<i>Iskandarova Shokhista Fekhruzovna, Dzhabbarov Nurilla Abdumakhsudovich, Umarova Shakhnoz Ziiyatovna</i>	
THE TECHNOLOGY OF OBTAINING THE DRY EXTRACT FROM THE FRUITS OF SOPHORA JAPANESE (SOPHORA JAPONICA L.) BY MODERN ACCELERATED METHOD	155
<i>Iskandarova Shokhista Fekhruzovna, Mamatkulov Zukhrudin Urmonovich</i>	
DETERMINATION OF POLYPHENOLIC COMPOUNDS IN THE DRY EXTRACT OBTAINED FROM THE LEAVES OF CAPERS SPINY (CAPPARIS SPINOSA).....	159

Kurbanazarov Muratbai Kunnazarovich, Abdullaeva Nuria Zhalgasovna, Palekeeva Gulzhakhan Parahatovna EVALUATION OF THE STATE OF EXTRA-SCOPE PATHOLOGY AT CHILDHOOD IN CHILDREN IN THE SOUTHERN REGION OF ARAL	162
Madazimov Madamin Muminovich, Kayumhodjaev Abdurashit Abdusalamovich, Madazimov Komil Madaminovich, Teshaboev Muhammadyahyo Gulomkadyrovich SURGICAL APPROACH TO TREATMENT OF PATIENTS WITH CONSEQUENCES OF THE CRANIAL VAULT BURNS	165
Maksudova Dilnoza Yunusovna DEMENTIA AS A GLOBAL PROBLEM OF XXI CENTURE	168
Makhmudova Zulfiya Primkulova THE ROLE OF PROINFLAMMATORY CYTOKINES IN THE PATHOGENESIS OF TUBERCULOSIS	171
Murtazaev Saidazim Saidagzamovich, Nasimov Elbek Elhonovich, Voidov Giyos Gulom uglu, Aminov Elmurod Komiljonovich, Murtazaev Saidmurodkhon Saidaloevich COMPARISON OF THE RESULTS OF SUPERIMPOSITION AS WELL AS MANUAL AND COMPUTER SOFTWARE OF CEPHALOMETRIC IMAGERY.....	174
Niyazov Shukhrat Tashmirovich, Djurabekova Aziza Takhirovna, Igamova Saodat Sur'atovna MORPHOLOGICAL STUDY OF RAT BRAIN IN THE EXPERIMENT WITH CHRONIC ENCEPHALITIS UNDER THE ACTION OF OZONIZED NEUROPROTECTORS.....	179
Ochilov Komil Rakhimovich INFLUECE OF IONS OF HEAVY METAL SALT ON BREATHING AND OXIDATIVE PHOSPHORYLATION OF MITOCHONDRIA OF RAT LIVER	186
Tashkenbaeva Eleonora Negmatovna, Abdieva Gulnora Alievna FEATURES OF ISCHEMIC HEART DISEASE IN ASSOCIATION WITH CLIMACTERIC CARDIOPATHY	190
Turakulov Rustam Ismatullaevich, Gadayev Abdugaffar Gadayevich DYNAMICS OF CYTOKINES AND LEVEL OF HEP SIDINE IN PATIENTS WITH CHRONIC HEART FAILURE WITH ANEMIA.....	193
Tukhtaev Nodirbek Kadirovich, Zokirova Nargiza Bakhodirovna, Tulemetov Sabirjan Khalikovich, Tukhtaev Kadir Rakhimovich THE MECHANISMS OF THE TOXIC EFFECT OF INTRAUTERINE AND EARLY POSTNATAL EXPOSURE TO PESTICIDES ON THE DEVELOPMENT OF THE IMMUNE SYSTEM OF OFFSPRING.....	196
Usmanova Shakhnoza Erkinovna, Yakubov Abdugalol Vahabovich, Hamraev Abror Asrarovich STATE OF COLLAGEN SYNTHESIS IN GASTRIC MUCOSA AND RENAL TISSUE IN INDOMETACIN GASTROPATHY IN ANIMALS WITH EXPERIMENTAL RHEUMATOID ARTHRITIS	200
Khabibullayev B. B., Batyrbekov A. A. THE INFLUENCE OF HARMALA AND KARELINIA CASPIA ON THE IMMUNE STATUS FOR RAY DISEASE IN EXPERIMENT	203

Khamraev Farhod Sharafovich NEUROPHYSIOLOGICAL EVALUATION OF THE EFFICIENCY OF TREATMENT OF BOTULOTOXIN OF SPASTIC FORMS OF INFANT CEREBRAL PALSY	207
Husanghodjaeva Malika Tursunkhodzhaevna MORPHOLOGICAL, MORPHOMETRIC CHANGES IN MOMOMATOUS NODES IN WOMEN WITH UTERINE MOMORY	211
Yusupalikhodjaeva Saodat Hamidullaevna, Bekjanova Olga Esenovna, Patkhiddinov Jaloliddin Sharofiddin o'gli BACKGROUND DISEASES AT PATIENTS WITH CANDIDIASIS OF ORAL CAVITY MUCOSA	215
Section 8. Pedagogy	220
Dolinskaya Ludmila Vasilievna PEDAGOGICAL CONDITIONS OF TRAINING OF THE TECHNICAL PROFILE SPECIALISTS TO CARRY OUT TRAINING ACTIVITIES IN HIGHER EDUCATION SHOOL	220
Rakhmatov Uchkun Ergashevich A PERFECTION OF THE PROFESSIONAL COMPETENCE OF TEACHERS BY USING OF CREATIVE WORKS IN BIOLOGY LESSONS UNDER SOLVING TASKS AND EXERCISES.....	225
Khasanova Gulsanam Khusanovna ESSENTIAL FEATURES OF VOCATIONAL EDUCATION SYSTEMS IN UZBEKISTAN AND JAPAN	228
Section 9. Political science	232
O'tamurodov Akbar THE MAIN STAGES OF THE FORMATION AND DEVELOPMENT OF CIVIL SOCIETY IN UZBEKISTAN.....	232
Section 10. Agriculture	235
Zhurlov Oleg Sergeevich, Grudinin Dmitriy Aleksandrovich, Mushinskiy Alexandr Alekseevich, Yakovlev Ilya Gennadievich METHODOLOGICAL APPROACHES TO MONITORING MICROBIAL COMMUNITIES OF AGRICULTURAL LANDSCAPE OF THE STEPPE ZONE	235
Section 11. Technical science	239
Alikulov Shuxrat Sharofovich THE RESEARCH OF INTENSIFICATION OF THE TECHNOLOGICAL PROCESSES OF IN SITU LEACHING OF URANIUM.....	239
Arifjanov Aybek Mukhamedjanovich, Akmalov Shamshodbek Bakhtiyarovich, Samiev Luqmon Nayimovich, Tursunoy Ubaydullaevna Apakxo'jaeva CHOOSING AN OPTIMAL METHOD OF WATER EXTRACTION FOR ARID REGIONS IN THE CASE OF BESHBULAK AND YANGIOBOD VILLAGES (SYRDARYA PROVICE, UZBEKISTAN)	244
Babakhanova Madina Avazovna, Negmatova Kamila Soyibjonovna MODIFIED ANTICORROSIVE PAINT COATINGS.....	249
Komilov Ne'matilla Muhammadjonovich THEORETICAL BASES OF FORMING AN EARTH BED BY MEANS OF SPHERICAL DISKS	251

Mamaraufov Odil Abdikhamitovich DETECTION AND DETERMINATION COORDINATES OF MOVING OBJECTS FROM A VIDEO.....	253
Mamatov Farmon Murtozevich, Toshtemirov Sanjar Jumaniyazovich, Xoliyarov Yormamat Berdiqulovich, Batirov Zafar Lutfullayevich ENERGY-RESOURCE-SAVING TECHNOLOGY AND A MACHINE FOR PREPARING SOIL FOR PLANTING COTTON ON THE RIDGES	261
Mamatov Farmon Murtozevich, Ergashev Ismoil Toshkentovich, Mirzaxodjaev Sherzodxuja Shoxruxovich, Xoliyarov Yormamat Berdiqulovich, Qurbanov Sherzod Baxtiyorovich PLOW FOR SMOOTH PLOWING WITH COMBINED WORKING BODIES.....	264
Mamatov Farmon Murtozevich, Batirov Zafar Lutfullayevich, Halilov Muhtor Suvonovich CHISEL-CULTIVATOR-FERTILIZER FOR FORMING RIDGES AND APPLYING FERTILIZERS.....	267
Mirsagdiyev Orifjon Alimovich EVALUATION OF THE QUALITY OF VOICE TRANSMISSION IN THE NETWORK OF AN OPERATIVE TECHNOLOGICAL NETWORK WITH PACKET SWITCHING	270
Pirmatov Nurali Berdiyrovich, Panoyev Abdullo Tilloyevich CALCULATION OF MECHANICAL CHARACTERISTICS OF INDUCTION MOTOR USED IN TEXTILE MACHINERY AT THE ENTERPRISE RUSHAN TEKS IN BUKHARA CITY.....	275
Rustamov Sherzod Rustamovich, Nasirova Naira Ravilevna CONSTRUCTIVE PECULIARITIES OF MODERNIZED CENTRIFUGAL PUMP	278
Tillaev Mamjabbor D. S., Yunusov Saloxiddin Zunnunovich, Axmedov Mirzokir Xakimovich EFFECT OF AIR FLOW ON THE YIELD OF FIBER AND SEEDS FROM THE WORKING CHAMBER OF GIN	281
Toshtemirov Sanjar Jumaniyazovich, Mamatov Farmon Murtozevich, Batirov Zafar Lutfullayevich, Chuyanov Dustmurod Shodmonovich, Ergashov G'ayrat Khudoyorovich, Badalov Sunnat Mamadiyevich ENERGY-RESOURCE-SAVING TECHNOLOGIES AND MACHINE FOR PREPARING SOIL FOR SOWING	284
Shayumova Zamira Mustafayevna APPLICATIONS OF A CONTROLLED ELECTRIC DRIVE WITH REACTIVE POWER COMPENSATION.....	287
Section 12. Physics.....	290
Barykinsky Gennady Mikhailovich THE UNIVERSE BEFORE, IN THE PROCESS, AND AFTER THE BIG BANG. PART I. THE PROJECT CREATOR.....	290
Section 13. Philology.....	298
Iplina Antonina Alexandrovna ORIGINAL POEM RECONSTRUCTION FEATURES.....	298

Martashvili Nato Elberdievna	
NATURE OF CORRELATION OF THE TITLE AND LITERARY TEXT (ON THE BASIS OF FRENCH LITERATURE)	301
Section 14. Philosophy	304
Nishanova Ozoda Jalolitdinovna	
FUNCTIONS OF ETHNIC CULTURE	304
Chmykhun S.	
COERCION MECHANISMS IN TRADITIONAL SOCIETIES WITHIN THE LEGAL NORMATIVITY SYSTEM	308
Section 15. Chemistry	313
Garayeva Shabnam Hamid gizi, Shahnazarli Rita Zeynal gizi, Ramazanov Gafar Abdulali oglu, Guliyev Abasgulu Mamed oglu	
SYNTHESIS OF CYCLIC ACETALS OF VINYLOXYCYCLOPROPANES AND PHOTOSENSITIVE POLYMERS ON THEIR BASIS	313
Section 16. Economy	322
Nushaba Hajiyeva, PhD., Ismailov Vugar	
CURRENT STATUS AND DEVELOPMENT ASPECTS OF CONSULTANCY SERVICE IN AZERBAIJAN	322
Petanaj Migena, Durmishi Veronika	
THE EFFECT OF TAX REDUCTION IN TOURISM AND THE DEVELOPMENT TRENDS OF THIS SECTOR IN ALBANIA	328
Huseynli Javid	
CORPORATE SOCIAL RESPONSIBILITY (CSR): GLOBAL CAPABILITY	332

