

ISSN 2310-5607



Austrian Journal of Technical and Natural Sciences

Premier Publishing s.r.o.

2024
1-2

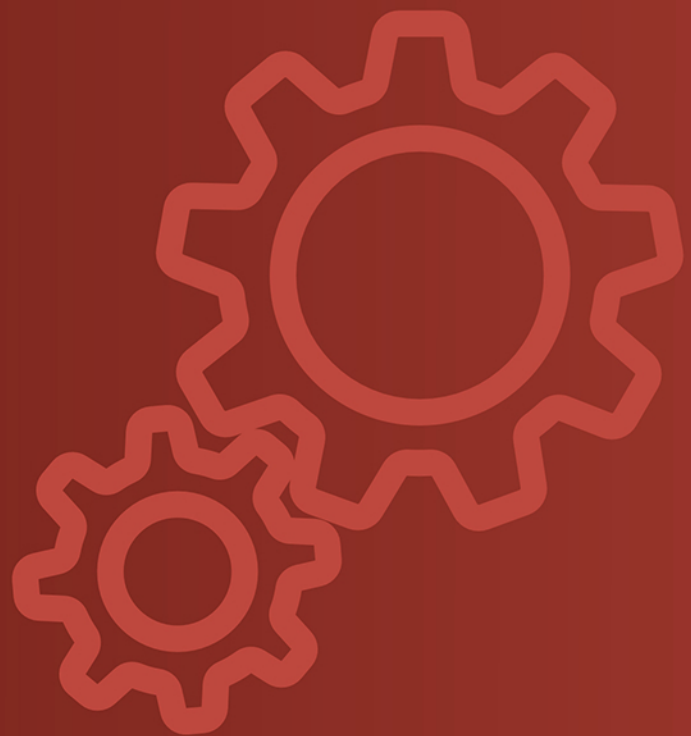

Austrian Journal of Technical and Natural Sciences

2024, No 1 – 2

Austrian Journal of Technical and Natural Sciences

Scientific journal

№ 1 – 2 2024

ISSN 2310-5607

Editor-in-chief

Hong Han, China, Doctor of Engineering Sciences

International editorial board

Atayev Zagir, Russia, Ph.D. of Geographical Sciences, Dagestan State Pedagogical University
Boselin S.R. Prabhu, India, Associate Professor, Surya Engineering College
Buronova Gulnora, Uzbekistan, PhD in Pedagogical science (Computer Science), Bukhara State University
Giorgi (Gia) Kvinikadze, Georgia, Doctor of Geographical Sciences, Tbilisi State University named after Ivane Javakhishvili
Inoyatova Flora Ilyasovna, Uzbekistan, Doctor of Medicine, Republican Specialized Scientific and Practical Medical Center of Pediatrics (RSNPMC Pediatrics)
Kurdzeka Aliaksandr, Kazakhstan, Doctor of Veterinary Medicine, Kazakh National Agrarian University
Kushaliyev Kaissar Zhalitovich, Kazakhstan, Doctor of Veterinary Medicine, Zhangir Khan Agrarian Technical University
Mambetullaeva Svetlana Mirzamuratovna, Uzbekistan, Doctor of Biological Sciences, Karakalpak Research Institute of Natural Sciences
Manasaryan Grigoriy Genrihovich, Armenia, Doctor of Technical Sciences, Armenian National Polytechnic University
Martirosyan Vilena Akopovna, Armenia, Doctor of Engineering Sciences, National Polytechnic University of Armenia
Nagiyev Polad Yusif, Azerbaijan, Candidate of Agricultural Sciences, Sciences Institute for Space Research of Natural Resources, National Aerospace Agency

Nenko Nataliya Ivanovna, Russia, Doctor of Agricultural Sciences, State Scientific Institution North Caucasus Zonal Research Institute of Horticulture and Viticulture of the Russian Agricultural Academy
Rayiha Amenzade, Azerbaijan, Dr. Sc. (Architecture), professor, Institute of Architecture and Art of ANAS (Azerbaijan)
Sharipov Muzafar, Uzbekistan, PhD in technical science, Associate professor, Bukhara State university
Skopin Pavel Igorevich, Russia, Doctor of Medicine, Mordovian State University
Suleymanov Suleyman Fayzullaevich, Uzbekistan, Ph.D. of Medicine, Bukhara State Medical Institute (BukhGosMI)
Tegza Alexandra Alexeevna, Kazakhstan, Doctor of Veterinary Medicine, Kostanay State University
Yarashev Kuvondik Safarovich, Uzbekistan, Doctor of Geographical Sciences (DSc), Director, Urgut branch of Samarkand State University named after. Sharaf Rashidov
Zagir V. Atayev, Russia, PhD of Geographical Sciences, Dagestan State Pedagogical University

Proofreading

Kristin Theissen

Cover design

Andreas Vogel

Additional design

Stephan Friedman

Editorial office

Premier Publishing s.r.o.

Praha 8 – Karlín, Lyčkovo nám. 508/7, PSČ 18600

E-mail:

pub@ppublishing.org

Homepage:

ppublishing.org

Austrian Journal of Technical and Natural Sciences is an international, English language, peer-reviewed journal. The journal is published in electronic form.

The decisive criterion for accepting a manuscript for publication is scientific quality. All research articles published in this journal have undergone a rigorous peer review. Based on initial screening by the editors, each paper is anonymized and reviewed by at least two anonymous referees. Recommending the articles for publishing, the reviewers confirm that in their opinion the submitted article contains important or new scientific results.

Premier Publishing is not responsible for the stylistic content of the article. The responsibility for the stylistic content lies on an author of an article.

Instructions for authors

Full instructions for manuscript preparation and submission can be found through the Premier Publishing home page at: <http://ppublishing.org>.

Material disclaimer

The opinions expressed in the conference proceedings do not necessarily reflect those of the Premier Publishing, the editor, the editorial board, or the organization to which the authors are affiliated.

Premier Publishing is not responsible for the stylistic content of the article. The responsibility for the stylistic content lies on an author of an article.

Included to the open access repositories:



TOGETHER WE REACH THE GOAL

SJIF 2024 = 6.62 (Scientific Journal Impact Factor Value for 2024).



Crossref

OAK.UZ

eLIBRARY.RU

Included to the Uzbekistan OAK journals bulletin.

© Premier Publishing

All rights reserved; no part of this publication may be reproduced, stored in a retrieval system, or transmitted in any form or by any means, electronic, mechanical, photocopying, recording, or otherwise, without prior written permission of the Publisher.

Section 1. Agriculture

DOI:10.29013/AJT-24-1.2-3-7



BIOGEOCHEMISTRY OF ZINC IN IRRIGATED SOILS OF THE DESERT ZONE

*Yuldashev Gulom*¹, *Mamajonov Inomzhon Noralieovich*¹,
*Makhramkhuzhaev Sultonkhuzha Akramkhuzha*¹

¹ Fergana State University

Cite: Yuldashev G., Mamajonov I. N., Makhramkhuzhaev S.A. (2024). *Biogeochemistry of Zinc in Irrigated Soils of the Desert Zone. Austrian Journal of Technical and Natural Sciences 2023, No 11-12.* <https://doi.org/10.29013/AJT-24-1.2-3-7>

Abstract

The work studied the geochemical, biogeochemical features of hydromorphic soils of the desert zone using the example of soils in the Yazyavan region, where the main emphasis was placed on the pedobiogeochemical features of Zn, in particular, on its accumulation and anomalies. The degree of positive and negative anomaly was developed.

Keywords: *geochemistry, biogeochemistry, accumulation, anomaly, hydromorphic, fertilizers, landscape*

Introduction

Zinc element is a chemical atom, distributed in nature in various sources and forms, its serial number in the periodic table of elements is 30, atomic mass is 65.4. It mainly migrates in the landscape and in its blocks as a divalent metal.

The ionic radius of zinc is 0.83 nm, Clarke of the lithosphere – 83 mg/kg, soil – 50 mg/kg. The main mineral of zinc is sphalerite, that is, ZnS; in addition, its minerals include wurtzite-ZnS, stylite-smithsonite-ZnCO₃, grosslorite-ZnSO₄ · 7H₂O, danite-ZnAl₂O₄, franklinite-(ZnMg)Fe₂O₄ and others. In arid climatic conditions, goslorite, smithsonite – ZnSe, zincite – ZnO, franklinite and others are found (Vinoogradov A. P. 1957).

One of the reasons for this is that the soils of the region are carbonate, saline, chloride-sulfate, sulfate type, rich in iron, so zinc accumulates in these soils in neutral and slightly alkaline environments. It migrates quite actively in hydrothermal waters.

Zinc precipitates together with chalcophile elements and accumulates. It is a major micronutrient among biophilic elements and is a relatively well-studied element for these purposes.

Zinc is involved in the activity of a number of enzymes and has its effect. In particular, its deficiency slows down the synthesis of vitamins, where the synthesis of ascorbic acid is reduced.

Its biological absorption index, that is, the coefficient of biological absorption by plants, is high. Accumulates in the upper layers of soil biogenically. Its accumulation is observed at a level of 45–50 mg/kg in humus soil horizons (Vinogradov A. P. 1957, Itoh S., Yumura Y., 1979, Kabata-Pendias, A. and Pendias, H., 2011). Generally, migrates well in acidic environments.

Its migration coefficient is high in gley and acidic waters (Kuziev R., YUldashev G., Akramov I., 2004). The concentration of zinc is relatively high in clayey sedimentary rocks and shales, i.e. 80–120 mg/kg. In sandstones, highly carbonate and gypsum soils it is 10–30 mg/kg. According to information presented in the literature (Kio S., Mikkelsen D.S., 1979), in soils of the USA there are cases of accumulation of 17–125 mg/kg, and in soils of Southern China – up to 236 mg/kg (Lindsay W.L., 1979, Norrish K., 1975). Chernozems contain about 63–97 mg/kg.

Zinc can migrate in the soil in Zn^{2+} , $ZnCl^+$, $ZnOH^-$, $ZnHCO_3^-$, ZnO_2 and other forms. Organic matter and humus are strongly absorbed and accumulated in appropriate quantities. In irrigated meadow soils, i.e., in carbonate, gypsum, phosphate and iron- and calcium-rich soils, the migration of zinc is sharply reduced, especially in carbonate-gypsum and gley barriers. Therefore, despite the fact that its total amount in the soil is quite large, in such condition's deficiency situations arise for plants. We should not forget that soils in irrigated agriculture, saline and carbonate, are fertilized almost annually with mineral and local fertilizers (Kuziev R., YUldashev G., Akramov I., 2004, YUldashev G., 2014).

Even then, there is a deficiency for normal plant growth and development. For example, with wastewater 700–49000 mg/kg, phosphorus fertilizers 50–1450 mg/kg, nitrogen fertilizers 1–42 mg/kg, organic fertilizers 15–250 mg/kg and 1.3 mg/kg pesticides are introduced into irrigated areas zinc (Kabata-Pendias, A., Pendias, H., 2011; Kuziev R., YUldashev G., Akramov I., 2004; YUldashev G., 2014). These quantities are retained in soils of an arid climate region, that is, they accumulate in carbonate, gypsum and bilateral, as well as gley barriers. Where abnormal concentrations may form over the years (Perelman A. I., 1989).

According to the literature (Tyler G., 1981, Quping Z., Chuliang Y., Lihua T., Junxiang X., 1984), the concentration of zinc in soil, which may indicate the level of phytotoxicity, exceeds 70 mg/kg. Particular attention should be paid to the fact that its phytotoxic concentration depends on a number of factors: mobile form, type of plant, soil pH, content of carbonates, sulfates, sulfur, humus, iron, phosphorus and others. However, it is fair to say that the effects of these conditions are not well understood, especially in saline desert soils. This situation is one of the complex problems.

The object of the study was irrigated, saline meadow and sandy desert soils, formed on an area of 19.583 hectares in the Yazyavan district of the Fergana region of Uzbekistan. Field research was carried out on the basis of Dokuchaev's morphogenetic and stationary methods. Mathematical and statistical analysis of the obtained results was carried out using the dispersion method, that is, the methods of Karimov, Yuldashev (Kuziev R., YUldashev G., Akramov I., 2004) and Samsonova (Samsonova V.P., Meshalkina YU.L., Dyad'kina S.E., 2005) using Microsoft Excel.

Quantitative determination of zinc in selected samples was determined using the Speivey, Nick method (Perkin Emler Avio 200 ICP-OES spectrophotometer at a wavelength of 206–200 nm, integration time 0.1–5 seconds, sample transfer rate 0.8 ml/min, transfer plasma gas 8 L/min The correlation coefficient between the amount in the standard solution and the amount in the equivalent sample is reported to be 0.99990.

Theoretically, plants feed on Zn^{2+} in the soil solution, but this may be hindered by other elements of the solution, in particular Ca^{2+} .

But zinc consumption is controlled by the plant through its metabolism. If you think deeper, then theoretically the factors that cause a state of zinc deficiency in plants include the following: – low Zn content in the soil; soil carbonate content;

– gypsum content, alkalinity, humus content of the soil; – distribution of the root system in the soil, biological activity; – plant type, growth phase; – antagonistic state with other elements, ions, irrigation regime; – soil contamination with this element and others.

Zinc is a chalcophile element and, in terms of toxicity, belongs to the first group of elements. According to preliminary data, wormwood is among the plants that absorb zinc; according to our information, in wormwood growing on stony-gravelly eroded and leached light gray soils, zinc accumulates in the range of 142–160 mg/kg, in contrast to the medicinal plant lavender where it the content reaches 129 mg/kg.

Thus, the geochemical and biogeochemical properties and distribution of trace elements in the soil, especially zinc, are not uniform in all cases. We can see this situation in the studied soils of the region. For this purpose, first of all, the obtained analysis results were mathematically processed.

According to the data obtained, the coefficient of variation of zinc in the soils of the Yangi Buston, Central Fergana, Karatal, Yangiabad, Istiklal, Karatepa, Ishtirkhan, Khanabad massifs is $V < 10$, which means that the spread of data is very low, and in the soils of the Gulistan, Karasokol massif, this indicator is 20–25%, that is, in Karasokol this coefficient is 20%, which means ($V = 10–20$) the dispersion is average, in Gulistan this figure is 25.4%, which means the dispersion is serious (Table 1).

But as a general rule, if the coefficient of variation is less than 33%, the set is considered homogeneous and can be used, which means the results obtained are correct. This

law holds true for the dispersion of zinc in the soil of the study area, so the results obtained can be used.

When determining the positive and negative anomalous state of zinc in the soil, the background indicator and the 3-fold value of the standard deviation and coefficients of variation are of great importance. It should be noted that classifications have not yet been developed for abnormal cases of zinc and some other trace elements.

Therefore, we recommend choosing for positive and negative cases of normal, weak, moderate, strong, high anomalies. To do this, first of all, the background value for the soils of the region is calculated from samples. Due to the fact that the soils of the region are carbonate, gypsum and saline, the background level turned out to be higher than expected, i.e. 83.8 mg/kg. Based on the results of statistical processing, the Zn concentration, that is, background amounts, was determined separately for each array (Table 1).

Anomalous values can be determined relative to the soil, lithosphere, biosphere or background. At the same time, i.e. When studying the soil-geochemical properties of Zn in the soils of the Yazyavan region, in particular its anomalous state, the amount of zinc in the irrigated soils of the region in the 0–30 sm layer was taken as the background for the soils of the region.

Table 1. Background amounts of zinc in soils of massifs

N	Massifs	n	Phon	δ	V	m
1.	Yangi Buston	14	52.2	2.32	4.44	1.04
2.	Central Fergana (state land reserve)	15	64.04	4.03	6.29	1.80
3.	Karatal	18	83.025	5.44	6.55	2.72
4.	Yangiabad	19	69.82	4.92	7.04	2.19
5.	Guliston	21	100.83	25.61	25.39	10.45
6.	Karasakal	20	115.0	22.99	19.99	11.49
7.	Istiqlal	14	54.25	3.77	6.94	1.88
8.	Karatepa	13	90.25	3.96	4.39	1.98
9.	Ishtirkhon	13	101.25	8.93	8.82	4.46
10.	Khanabad	19	115.25	10.84	9.41	5.42

It should be noted that positive and negative abnormal states of the element lead to various endemic diseases. In particular, zinc deficiency affects the growth, development, and height of plants.

The leaves of fruit trees become smaller, as a result, metabolism at the leaf level slows down, ultimately reducing yield and deteriorating quality. In corn and other grain crops, zinc deficiency leads to chlorosis, etc.

The works of A.I. Perelman (Perelman A. I., 1989) can be useful in determining positive and negative anomalies of chemical elements in the soil. To determine the positive anomaly, the A.I. formula is convenient. Perelman (Perelman A. I., 1989), which has

the following form: $Ca \geq Cf + 3d$, Ca is the anomalous concentration of the element; Cf – background element containment; d – standard deviation or dispersion. The negative anomaly of chemical elements in the soil is calculated using the formula

Table 2. Anomalous concentrations of zinc in hydromorphic soils of the massifs

N	Massifs	Sample numbers	Σ	Anomalies		Degree of anomaly	
				+ ¹	- ²	+ ¹	- ²
1.	Yangi Buston	1, 2, 3, 4, 5	6.96	59.16	45.24	not	weak
2.	Central Fergana (state land reserve)	6, 7, 8, 9, 10, 46	12.03	76.13	51.95	weak, middle, high	weak
3.	Karatal	11, 12,13,14	16.32	99.35	66.71	middle	weak
4.	Yangiabad	15, 16, 17	14.76	84.56	55.06	weak, middle, strong	weak
5.	Guliston	19, 24	76.83	177.66	24.0	strong	not
6.	Karsakal	18, 40,41,42	68.97	183.97	40.03	strong, high	not
7.	Istiklal	28, 29, 30	11.31	65.56	42.94	not	not
8.	Karatepa	20, 21, 22, 23, 31, 32, 33, 34,35	11.88	102.13	78.37	middle	weak
9.	Ishtirkhan	36, 37,38,39	24.99	126.24	76.26	middle	weak
10.	Khanabad	24, 25, 26,27, 43, 44, 45	32.52	147.77	82.73	middle	weak

¹ – positive, ² – negative

Figure 1. Soil-geochemical digital electronic map of Yazavan region

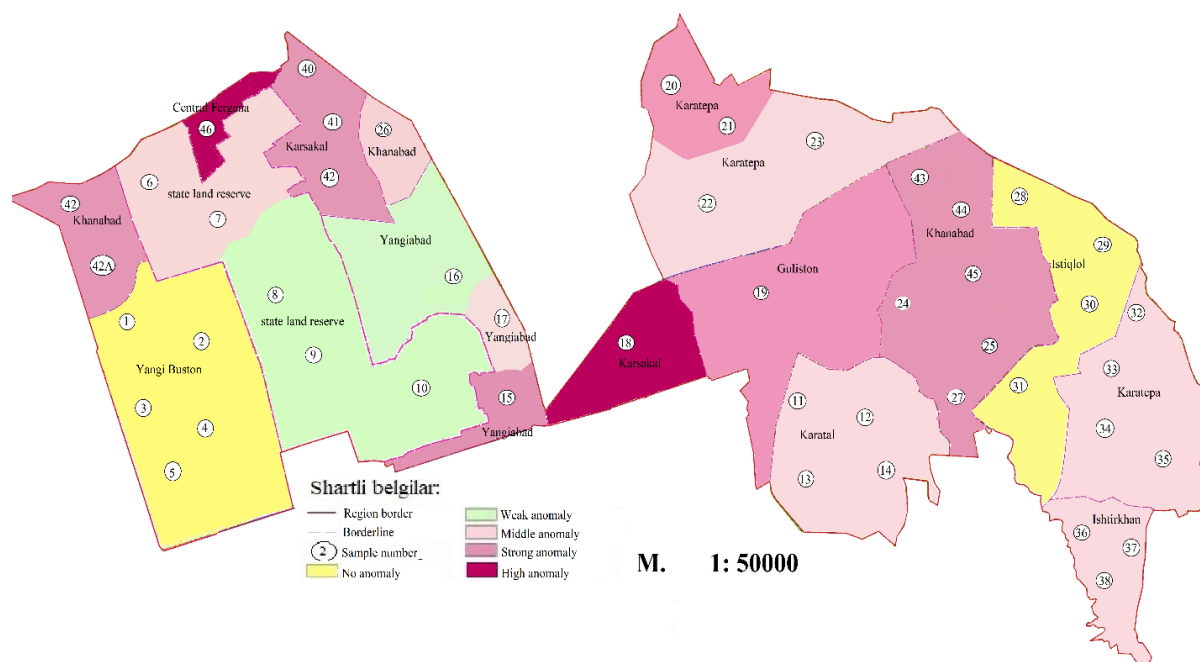

$Ca < Cf - 3d$ (Table-2). For positive abnormal cases <70 there are no abnormalities; 70–100 weak anomalies; 100–130 average anomaly; 130–160 strong anomaly; > 160 high anomaly.

For negative abnormal cases, the following indications are recommended: < 45 no negative abnormalities; 45–60 weak; 60–75 average; 75–100 strong; > 100 high. According to the results obtained for the zinc anomaly, strong anomaly corresponds to the Khanabad, Ishtirkhan, Karatepa and Karasakal, Gulistan massifs, where a zinc province of high content is clearly distinguished (fig. 1).

In conclusion, it can be noted that the state of zinc anomaly in the soils of the region manifests itself both positive and negative. The reason for the high positive anomaly in the old irrigated soils of the region, in particular the Khanabad, Gulistan, Karatepa, Karasakal massifs, is the rather high zinc content in phosphorus and local fertilizers applied to cotton and other agricultural crops, as well as slightly alkaline, neutral reactions of the soils where zinc accumulates in carbonate-gypsum, double-sided and evaporation barriers.

References

- Vinogradov, A. P. (1957). *Geohimiya redkih i rasseyannyh himicheskikh elementov v pochvah* – M. – 238 p.
- Itoh, S., Yumura, Y., (1979). Studies on the contamination of vegetable crops by excessive absorption on heavy metals, *Bull. Veg. Ornamental Crops Res. St.*, 6a, – 123 p.
- Kabata-Pendias, A. and Pendias, H. (2011). *Trace Elements in Soils and Plants*. 4th Edition, CRC Press, Boca Raton.
- Kio, S., Mikkelsen, D. S., (1979). Zinc adsorption by two alkaline Soils, *Soils Sci.*, 128, – 274 p.
- Kuziev, R., Y., Uldashev, G., Akramov, I. (2004) *Bonitirovka pochv* – T. – 127 p.
- Lindsay, W. L. (1979). Zinc in soils and plant nutrition *Adv. Agron.* 24, – 147.
- Norrish, K. (1975). The geochemistry and mineralogy of trace elements, in: *Trace Elements in Soil, Plant, Animal systems*, Nicholas D. S. D., Egan A. R., Eds., Academic Press, – New York, – 55 p.
- Perelman, A. I. (1989). “*Geoximiya*” – M. – 528 p.
- Samsonova, V. P., Meshalkina, YU. L., Dyad’kina, S. E. (2005). *Komp’yuternyj praktikum po kursu: matematicheskaya statistika v pochvovedenii*. – M. – 36 p.
- Tyler, G. (1981). Leeching of metals from the A- horizon of spruce forest soil, *water Air soil pollut.*, – 15. – 353 p.
- YUldashev, G. (2014). *Isagaliev, M. T. Biogeohimiya pochv* – T. – 352 p.
- Quping, Z., Chuliang, Y., Lihua, T., Junxiang, X. (1984). Content and distribution of trace elements in limestone soils of China, *Acta Pedologica sinical* – 21. – 58 p.

submitted 22.01.2024;

accepted for publication 06.02.2024;

published 18.03.2024

© Yuldashev G., Mamajonov I. N., Makhramkhuzhaev S. A.

Contact: gulyam48@mail.ru

Section 2. Biology

DOI:10.29013/AJT-24-1.2-8-12



THE INFLUENCE OF ENVIRONMENTAL FACTORS ON THE HEALTH OF STUDENTS AT ACADEMIC LYCEUMS IN THE REPUBLIC OF KARAKALPAKSTAN

*Ramazanov Medetbay Baxitbaevich*¹

¹Nukus branch of the Uzbek State University physical culture and sports acting

Cite: Ramazanov M.B. (2024). *The Influence of Environmental Factors on the Health of Students at Academic Lyceums in the Republic of Karakalpakstan. Austrian Journal of Technical and Natural Sciences 2023, No 11-12.* <https://doi.org/10.29013/AJT-24-1.2-8-12>

Abstract

The article discusses the influence of environmental factors on the health of students at academic lyceums in the Republic of Karakalpakstan. Regression equations were obtained that indicate the dependence of the level of general morbidity among adolescents on the degree of total air pollution.

Keywords: *Health preservation, environmental factors, physical education, approaches, monitoring, environment, adaptation*

Introduction

The problem of forming and maintaining the health of the younger generation in the context of socio-economic transformations and environmental aggravation of the environment in most regions of the world is very relevant (Kuchma, V.R., Suhareva, L.M., 2012; Baranov, A.A., Kuchma, V.R., Skoblina, N.A., Milushkina, O.YU., Bokareva, N.A., 2012).

At the present stage of development of society, environmental factors and lifestyle have a great influence on the formation of the health of the younger generation (Rahmanin, YU.A., Mihajlova, R.N., 2014). Adolescence is one of the critical stages in a person's life. Due to anatomical, physiological and morphofunctional characteristics at this age, the body

becomes especially vulnerable and unprotected from the effects of various unfavorable environmental factors and suffers even from sub-threshold concentrations of harmful substances (Tepper, E.A., Taranushenko, T.E., Manchuk, V.T., Grishkevich, N.YU., Galonskij, V.G. 2012; Bokareva, N.A., Skoblina, N.A., Milushkina, O.YU., Besstrashnaya, N.A., Sapunova, N.O., 2015). The main risk factors for the lifestyle of students studying in academic lyceums of Karakalpakstan are non-compliance with hygienic standards of the regime and organization of the educational process, conditions and organization of nutrition and physical education (Kuchma, V.R., Milushkina, O.YU., Bokareva, N.A., Detkov, V.YU., Fedotov, T.M., 2013).

As is known, the health of children and adolescents is determined not only by the presence or absence of diseases, but also by harmonious and age-appropriate development, the normal level of basic functional indicators (Fedotova, T.A., Zhmakin, I.A., Maslov, A.N., Vasil'ev, P.V., 2011). Many studies have noted a decrease in the functional capabilities of the body and the effectiveness of adaptation of the body of children and adolescents to changing environmental conditions (Rahmanin, YU.A., Mihajlova, R.N., 2014; Kuchma, V.R., Milushkina, O.YU., Bokareva, N.A., Detkov, V.YU., Fedotov, T.M., 2013). The educational environment often does not contribute to the preservation of the health of students and creates conditions for the formation of pathology, especially in persons with reduced adaptive capabilities (Bokareva, N.A., Skoblina, N.A., Milushkina, O.YU., Besstrashnaya, N.A., Sapunova, N.O., 2015; Fedotova, T.A., Zhmakin, I.A., Maslov, A.N., Vasil'ev, P.V., 2011).

However, problems of health problems in the child population associated with the negative impact of environmental factors persist, especially in the regional center, which requires monitoring, development and adoption of measures to improve the situation.

Material and methods

The object of the study was students studying in academic lyceums in the city of Nukus and Chimbay district of the Republic of Karakalpakstan. The subject of the study was the components of the environment, conditions of education and training in educational organizations and the health of students. The assessment of the quality of the living environment and the health status of adolescents is based on our own research, medical and statistical indicators, socio-hygienic monitoring data for 2020–2023, statistical materials provided by the Ministry of Economy and Statistics of the Republic of Karakalpakstan, the results of laboratory studies of the Karakalpak Research Institute natural sciences. The study involved 250 adolescents aged 15–17 years. The examination was carried out on the basis of their voluntary informed consent. To identify the relationship between the quality of atmospheric air and the morbidity rate of the adolescent popula-

tion, correlation analysis was used to determine the Pearson pair correlation coefficient the statistical relationship between environmental factors and the functional state of the cardiorespiratory system was identified using the method of correlation analysis (Spearman). The reliability of the results obtained was assessed using the Student test, the critical level of statistical significance p was taken equal to 0.05. Calculations were carried out in the universal statistical program Statgraf for windows using the “multiple regression” module and the stepwise regression method. The stepwise regression method consists in the fact that at each step the independent variable we are studying is included in or excluded from the model.

Results and its discussion

The construction of a model describing the relationship between the incidence and pollution of atmospheric air and tap water in the Republic of Karakalpakstan was calculated on the basis of the following factors: atmospheric air was studied – dust, SO₂, NO₂, NH₃, H₂S, Co; for tap water – turbidity, dry residue, sulfates, chlorides, nitrates.

Many of the most “significant” variables are highlighted. this allows you to identify and reduce the number of variables that reliably describe the relationship. inclusion of variables is determined using the Fisher criterion – F.

Correlation-regression analysis allows you to quantitatively measure the closeness and direction of the connection (correlation analysis), as well as establish an analytical expression for the dependence of the result on specific factors, while maintaining the constancy of the other factor characteristics acting on the resultant characteristic (regression analysis). We, in order to study the influence on the morbidity level of the population of Karakalpakstan (modeled sign Y) of a number of factors (factorial signs – X₁, X₂, X₃, X₄ and X₅), multiple correlation-regression analysis was used as a mathematical model apparatus between the morbidity indicators of the population and concentrations of atmospheric air pollutants and the quality of tap water in all regions of the republic. Based on the calculation results, reliable and adequate probabilistic multiple regression models were

obtained linking the morbidity of the population with several variables X. Before building the models, preliminary transformations were performed, namely, the incidence rates were logarithmized (the natural logarithm was calculated) to stabilize the variance the overall quality of the resulting models was assessed using multiple correlation coefficients (R), determination (R²) and Fisher's criterion (F) multiple correlation coefficient r is the degree to which two or more independent variables (variables x) are related to the dependent variable Y. By definition, it is equal to the square root of the coefficient of determination (R²). coefficient of determination (R²) – shows the degree to which the process is described by the model. The R² value is an indicator of the degree of fit of the model to the data (an R² value

close to 1.0 indicates that the model explains almost all of the variability in the relevant variables). Fisher criterion (F) – evaluates the validity and reliability of the model by the level of significance (p or significance F), which should be less than the calculated value F.

At the same time, due to the uniqueness of the large-scale wind removal of salts from the dried bottom (Fig. 1), there are no quantitative estimates of the connection between the increased concentration of sulfates and chlorides in the atmosphere and the increase in the number of respiratory tract diseases in the world literature. Model calculations showed the spatial and temporal coincidence of the salt concentration field with the zoning and dynamics of respiratory tract diseases.

Figure 1. Wind removal of salts March 15, 2002, synthesized (1–3 channels) satellite image NOAA

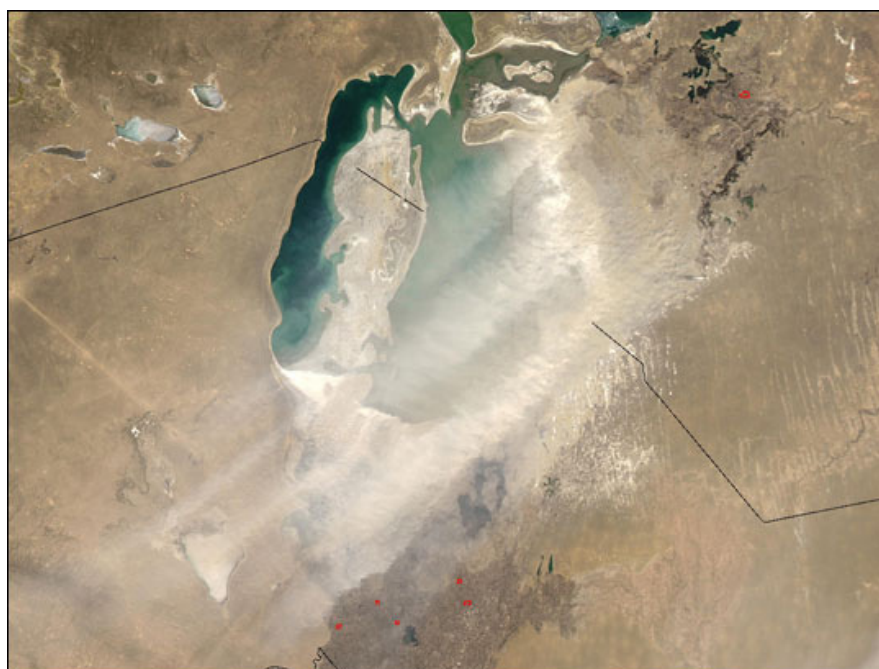

The high correlation coefficient ($r=0.69$) justifies the relevance of continuing this study regarding the dynamics of other pathologies in the southern Aral Sea region, as well as in order to obtain an analytical expression for the connection “salt removal → disease dynamics”. In order to predict changes in the level of general morbidity depending on the intensity of air pollution, mathematical modeling was carried out using methods of correlation and regression analysis. A number of regression equations were obtained reflect-

ing the dependence of the general morbidity of children of various age groups on the integral indicator of atmospheric air pollution.

$$Y = 262.7 + 60.34 * X_1$$

$$Y = 473.21 + 13.42 * X_2$$

$$Y = 276.33 + 100.74 * X_3$$

where Y is the level of general morbidity among children

X_1, X_2, X_3 – integral coefficient indicator for different zones (northern, central and southern).

The obtained regression equations indicate a direct dependence of the level of general morbidity of the child population on the

degree of total air pollution: the more significant the degree of air pollution, the higher the level of morbidity.

Table 1. Indicators of regression statistics and analysis of variance

Name of territory	Coefficient		Fisher criteria, F	
	Multiple correlation, R	Determination, R ²	F calculated	Significance F
Nukus city	0.84	0.68	11.77	0.05
Chimbay district	0.76	0.63	6.25	0.09

In our calculations, the resulting models for all studied areas are characterized by high reliability and reliability (F calculated > > significance F) and high prediction accuracy (Table 1), i.e. the model describes the phenomenon well (R² > 0.7). multiple correlation coefficients for all parameters (R > 0.95) indicate a close connection between factor characteristics and the results.

Thus, the multifactorial nature of the processes of formation of students' health makes it difficult to assess its condition and iden-

tify cause-and-effect relationships between the influence of environmental factors and health status. all this requires choosing the most informative indicators of the environment and health of the younger generation. The environmental factors, educational environment and lifestyle of students in general education institutions identified during the study, which contribute to a decrease in their functional reserves, leading to increased morbidity, need correction in order to preserve health.

References

- Kuchma, V. R., Suhareva, L. M. Sanitarno-epidemiologicheskoe blagopoluchie detej i podrostkov v sovremennyh usloviyah: problemy i puti resheniya. *Zdorov'e naseleniya i sreda obitaniya*. 2012.– № 8.– P. 4–6.
- Baranov, A. A., Kuchma, V. R., Skoblina, N. A., Milushkina, O. YU., Bokareva, N. A. Osnovnyye zakonomernosti morfofunkcional'nogo razvitiya detej i podrostkov v sovremennyh usloviyah // *Vestnik RAMN*. 2012.– № 12.– P. 4–6.
- Tepper, E. A., Taranushenko, T. E., Manchuk, V. T., Grishkevich, N. YU., Galonskij, V. G. Osobennosti morfofunkcional'nogo statusa detej na raznyh etapah shkol'nogo obrazovaniya // *Sibirskij medicinskij zhurnal – (Tomsk)*. 2012.– № 27(4).– P. 83–7.
- Rahmanin, YU. A., Mihajlova, R. N. Okruzhayushchaya sreda i zdorov'e: priority profilakticheskoy mediciny // *Gigiena i sanitariya*. 2014.– № 93(5).– P. 5–10.
- Bokareva, N. A., Skoblina, N. A., Milushkina, O. YU., Besstrashnaya, N. A., Sapunova, N. O. Gigienicheskaya karakteristika mediko-social'nyh faktorov i obraza zhizni sovremennyh moskovskih shkol'nikov // *Zdorov'e naseleniya i sreda obitaniya*. 2015.– № 5.– P. 6–33.
- Kuchma, V. R., Milushkina, O. YU., Bokareva, N. A., Detkov, V. YU., Fedotov, T. M. Gigienicheskaya ocenka vliyaniya sredovyh faktorov na funkcional'nye pokazateli shkol'nikov // *Gigiena i sanitariya*. 2013.– № 5.– P. 91–4.
- Fedotova, T. A., Zhmakin, I. A., Maslov, A. N., Vasil'ev, P. V. Sravnitel'nyj analiz slyuny u detej v zavisimosti ot sanitarno-gigienicheskikh karakteristik rajonov prozhivaniya // *Voprosy prakticheskoy pediatrii*. 2011.– № 6 (4).– P. 103–4.
- Setko, A. G., Trishina, S. P., Terekhova, E. A., Mokeeva, M. M. Rezul'taty donozologicheskoy diagnostiki sostoyaniya zdorov'ya uchashchihsya sovremennogo obrazovatel'nogo uchrezhdeniya // *Zdorov'e naseleniya i sreda obitaniya*. 2015.– № 6.– P. 9–26.
- Ramazanov, M. B. "To the Question of Research of the Functional State of the Cardiorespiratory System of Lyceum Students in the Conditions of Karakalpakstan". *International Journal of Current Microbiology and Applied Sciences (IJCMAS) Int.J.Curr.Microbiol.App. Sci.* 2022.– 11(3).– P. 377–379.

Ramazanov, M. “Problemy issledovaniya funkcional’nogo sostoyaniya regulyatornyh sistem organizma uchashchihsya liceev Karakalpakstana” «Koncepcii ustojchivogo razvitiya nauki v sovremennyh usloviyah» Sbornik statej po itogam Mezhdunarodnoj nauchno-prakticheskoj konferencii CHelyabinsk 9 dekabrya 2021.– P. 11–13.

submitted 01.02.2024;
accepted for publication 16.02.2024;
published 18.03.2024
© Ramazanov M. B.
Contact: medetramazanov@inbox.ru



Section 3. Chemistry

DOI:10.29013/AJT-24-1.2-13-18



STUDYING THE REACTION OF BAP WITH SUCCINIC ACID AND ITS EFFECT ON THE ROOTING OF THE SEEDLING OF THE VARIETY "BUKHARA-102"

Baymuratova G.O'¹, Saitkulov F.E.¹

¹Tashkent state Agrarian Universitet

Cite: Baymuratova G.O', Saitkulov F.E. (2024). *Studying the Reaction of Bap With Succinic Acid and Its Effect on The Rooting of the Seedling of the Variety "Bukhara-102". Austrian Journal of Technical and Natural Sciences 2023, No 11-12.* <https://doi.org/10.29013/AJT-24-1.2-13-18>

Abstract

In our previous study, we demonstrated methods for the synthesis of the coordination compound 6-benzylaminopurine with hexahydrate cobalt-II nitrate. Continuing our research, we studied the influence of the resulting coordination connection on the shipping of the Bukhara-102 cottons.

Keywords: 6-benzylaminopurine, Bukhara-102 cotton, hexahydrate cobalt-II nitrate, coordination compounds, chelating ligands

Introduction

L.A. Chugaev's scientific works relate to various fields of chemistry: he studied the analytical and biological activity of organic compounds, developed a method for converting alcohols into hydrocarbons by thermal decomposition of methylxanthogenates, discovered an anomalous rotational dispersion of organic molecules with two asymmetric centers with opposite signs of rotation. His works on the chemistry of complex compounds have received worldwide recognition. So, in 1906, he established a rule according to which the most stable complex compounds contain five- or six-membered cycles (Sapaev, J., 2020; Gulbakhar Baymuratova, Khasan Nasimov

and Foziljon Saitkulov, 2023; Saitkulov, F.E., Tashniyazov, A.A., Mamadrahimov, A.A., & Shakhidoyatov, K.M., 2014; Sapaev, B., Saitkulov, F.E., Tashniyazov, A.A., & Normurodov, O.U., 2021).

The chemistry of heterocycles is one of the most fascinating and important areas of organic chemistry. Suffice it to say that of the most well-known and widely used medicines of natural and synthetic origin, more than 60% are heterocyclic compounds. The presence of a heteroatom in the cycle brings a unique originality to the chemical properties and determines the specifics of synthesis methods. The variety of heterocyclic compounds is due to the possibilities of variations: the number and nature

of heteroatoms in the molecule, the size of the cycle, the degree of unsaturation, which determines the presence or absence of aromaticity, the possibility of the existence of condensed structures. The main attention in the methodological development is paid to the most common methods of synthesis and chemical properties of the main classes of aromatic heterocyclic structures. This choice is due to the fact that it is aromatic heterocycles that exhibit specific chemical properties inherent only in these classes of compounds, whereas the properties of saturated structures or unsaturated non-aromatic heterocycles, as a rule, are similar to their acyclic analogues. Information about the presence of heterocyclic compounds in natural objects, about medicines containing heterocycles and other “secondary” information, in our opinion, is highlighted in small print and is intended for the development of general erudition, and not for memorization and learning (Sapaev, B., Sapaev, I. B., Saitkulov, F. E., Tashniyazov, A. A., & Nazaraliev, D. 2022; Baymuratova, G., Nasimov, K., & Saitkulov, F., 2023; Khatamov, K., Saitkulov, F., Ashurov, J., & Shakhidoyatov, K., 2012; Foziljon Saitkulov, Bairamdurdi Sapaev, Khasan Nasimov, Dilorom Kurbanova and Nargiza Tursunova, 2023; Bairamdurdi Sapaev, Foziljon Saitkulov, Muattar Mamedova, Shahlo Saydaliyeva and Dilafruz Makhmudova. 2023; Сайткулов, Ф.Э., Элмуратов, Б.Ж., & Гиясов, К., 2023; Saitkulov, F., Qilichyeva, N., Abdullayev, B., Anvarov, A., & Ergasheva, M., 2022; Saitkulov, F., Farhodov, O., Olishyeva, M., Sapparboyeva, S., & Azimova, U., 2022; Boymuratova, G. O., Saitkulov, F. E., Nasimov, K. M., & Tugalov, M., 2022; Murodillayevich, K. M., Shoyimovich, K. G., & Ergashevich, S. F., 2022; Сайткулов, Ф.Э., 2022; Saitkulov, F., Begimqulov, I., O'ralova, N., Gulimmatova, R., & Rahmonqulova, D., 2022; Saitkulov, F., Elmuradov, B., O'lmasova, K., & Alijonova, A., 2023; Bairamdurdi Sapaev, Foziljon Saitkulov, Muattar Mamedova, Shahlo Saydaliyeva and Dilafruz Makhmudova, 2023).

Thus, reagents for gravimetric determination should form sufficiently insoluble crystalline precipitates with the substances to be determined, but at the same time they themselves dissolve well in water, and also have a large molar mass. The solubility of organic reagents is determined by the num-

ber of functional groups available for hydration: $-SO_3H$, $-COOH$, $-OH$, $-NH_2$. Chelates of such reagents can be poorly soluble in water, since during the formation of complexes, hydrating groupings are completely blocked. For example, the sodium salt of anthracitic acid it is well soluble in water. However, the complexes of this substance with most divalent metals are poorly soluble in water, since both hydrophilic centers in the reaction product are blocked.

Reagents for photometric determination must have an intense color – or the color must appear when they interact with the substances being determined. If the photometric determination is carried out in an aqueous solution, then the resulting chelate should be well soluble in water. The solubility increase, as already noted above, is facilitated by the presence of hydrophilic functional groups in the reagent molecule. For example, alizarin is practically insoluble in water, while its sulfonic derivative, alizarin-3-sulfoxide – lot, is soluble in water (Bairamdurdi Sapaev, Foziljon Saitkulov, Muattar Mamedova, Shahlo Saydaliyeva and Dilafruz Makhmudova. 2023; Сайткулов, Ф.Э., Элмуратов, Б.Ж., & Гиясов, К., 2023; Saitkulov, F., Qilichyeva, N., Abdullayev, B., Anvarov, A., & Ergasheva, M., 2022; Saitkulov, F., Farhodov, O., Olishyeva, M., Sapparboyeva, S., & Azimova, U., 2022; Boymuratova, G. O., Saitkulov, F. E., Nasimov, K. M., & Tugalov, M., 2022; Murodillayevich, K. M., Shoyimovich, K. G., & Ergashevich, S. F., 2022; Сайткулов, Ф.Э., 2022; Saitkulov, F., Begimqulov, I., O'ralova, N., Gulimmatova, R., & Rahmonqulova, D., 2022; Saitkulov, F., Elmuradov, B., O'lmasova, K., & Alijonova, A., 2023; Bairamdurdi Sapaev, Foziljon Saitkulov, Muattar Mamedova, Shahlo Saydaliyeva and Dilafruz Makhmudova, 2023).

Metallochromic indicators should form soluble complex compounds with metal cations, the color of which differs from the color of the free indicator. Metal complexes with a titrant should be more stable than complexes with an indicator.

The use of organic reagents in analytical chemistry is not limited to complexation reactions: some reagents form poorly soluble simple salts with the ions being determined, for example, the K^+ cation forms a poorly soluble salt with the tetraphenylborate ion, and the sulfate ion forms with the benzidine dication.

Organic reagents are known to take part in redox reactions. Such reagents are used in qualitative analysis, to mask interfering ions (ascorbic acid) or as redox indicators.

Sometimes, when an organic reagent interacts with the ions being determined, new organic substances with characteristic chemical-analytical properties are formed: for example, when nitrite ions interact in an acidic medium with primary aromatic amines, diazonium salts are formed, which then react with phenols or aromatic amines to form azo dyes.

Some organic reagents are involved in catalytic reactions. In particular, when luminol (3-aminophthalic acid hydrazide) is oxidized with hydrogen peroxide at pH > 8.5, chemiluminescence occurs. This process is catalyzed by micro quantities of some metals, for example Cu^{2+} . Luminol is used

for chemiluminescent determination of metal cations.

Currently, the number of beneficial microorganisms living in the soil is decreasing, as well as endemic bacteria that affect the processes of plant growth from the air.

Continuing our research, we studied the influence of the resulting coordination connection on the shipping of the Bukhara-102 cotton.

Methods and results

Adenine of sodium benzylate, and benzyl alcohol were added to the flask (the molar ratio of adenine, sodium benzylate, benzyl alcohol is and with stirring boiled for 2.5 hours. Cooled to room temperature, 150 ml of diethyl ether was added and the precipitate was filtered. Sodium salt of 6-benzylaminopurine was obtained, the yield was 94%.

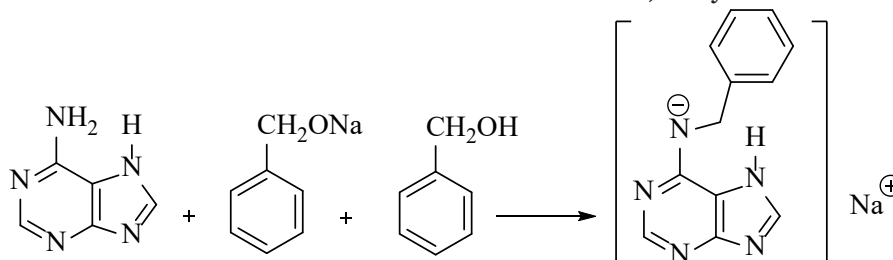

Sodium salt of 6-benzylaminopurine was dissolved in 150–200 ml of hot water, 1.3–1.5

ml of acetic acid was added to pH 6.5–7.5, cooled to room temperature and filtered, dried.

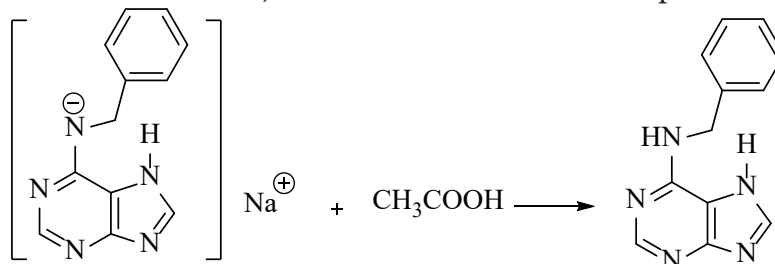

When the structure of 6-benzylaminopurine molecule was analyzed by ^1H NMR spectrum, it was found that the molecular bonds are as follows.

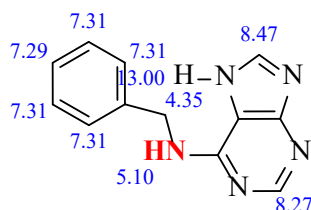

The structure of the BAP molecule shows that the nitrogen atoms in the heterocyclic purine ring do not undergo a chemical reaction.

Since the nitrogen atom in the seventh position is occupied by the benzyl radical, it also does not participate in chemical processes.

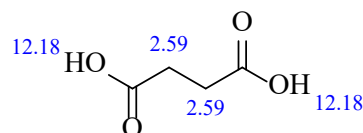

Succinic acid is a dibasic saturated aliphatic acid. It is determined that it occurs mainly in anion form in cell metabolism. In the Kerbs-Hans cycle, the intermediate product of citric acid, γ -aminobutyrate, is a product of catabolite reactions, and heme

production plays an important role in heme biosynthesis.

Due to the fact that it is not possible to express the acidic or basic properties of all compounds by means of the dissociation constant, R. Pearson proposed to divide Lewis acids and bases into hard and soft ones. Hardness and softness cannot be measured precisely; they can only be described qualitatively.

According to R. Pearson's strong soft acid bases principle, it is convenient for strong acids to react with strong bases, and soft acids with soft bases.

According to Hammond's postulate, the geometry (structure) of the transition state is similar to the geometry (structure) of substances with free energies close to it, and this state is appropriate for each stage of the re-

action. The time of existence of the activated complex is equal to the vibration time of one molecule (10–13 h), so it is impossible to isolate and study it experimentally. The correctness of the transition state theory can only be proved by calculations. In multi-step reactions, there are several transition states, in which case the highest energy value is taken as the activation energy. After the transition state, new bonds are formed in the molecules, and old bonds are broken or reformed. According to the above principles and rules, we dissolved succinic acid with BAP in absolute ethyl alcohol. The solution was heated in a water bath at 78–80 °C for 6 hours under reflux. Cooled, recrystallized. Washed with alcohol. The resulting compound was analyzed spectrally.

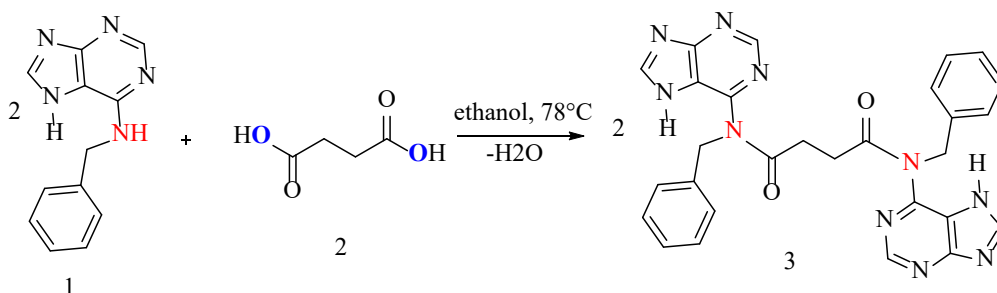

Method and Methodology

The effects of compounds (**3**) of cotton Gossypium on varieties "Bukhara-102" were studied.

The expected results in our experiment consists of the following stages.

In order to determine the biological activity of the resulting compound (**3**), first 2.5 g of substance (**3**) was dissolved in 10 ml of alcohol and 5 g of substance (**3**) in 10 ml of alcohol, 90 ml of deionized water was added to each of the resulting solutions. The solutions were ready. After that, the following processes were carried out.

20 seeds in 2.5% solution for 5 and 10 hours, 20 seeds in 5% solution for 5 and 10 hours in solution were poured.

Effect compounds (**3**) on seed germination. Seeds of 4 petri dishes and 1 20 pcs at equal distances. In total, the sample was placed in a thermostat in 5 Petri dishes. The temperature is 27 °C, humidity is 40%. 2.5 and 5 hours, the seeds are soaked in a 5% solution for 10 hours. the processes of increase were observed, 5% in 5 hours the seeds were soaked in solution for 10 hours, the processes of enlargement were observed. The root growth rate is performed in the same order. For 10 hours in 5% solution as the roots grow. It is desirable to sow seeds evenly. We're counting on it.

Table 1.

№	Concentration%	Bukhara-102, Fertility			
		Hours 5, sm	Hours 10, sm	temperatur°C	Humidity%
1	example	2.2	2.3	27	40
2	2.5	2.4	2.6	27	40
3	5	2.7	2.9	27	40

Diagram 1. “Bukhara-102” seedling root sample and 2.5% and 5% seeds are represented as follows

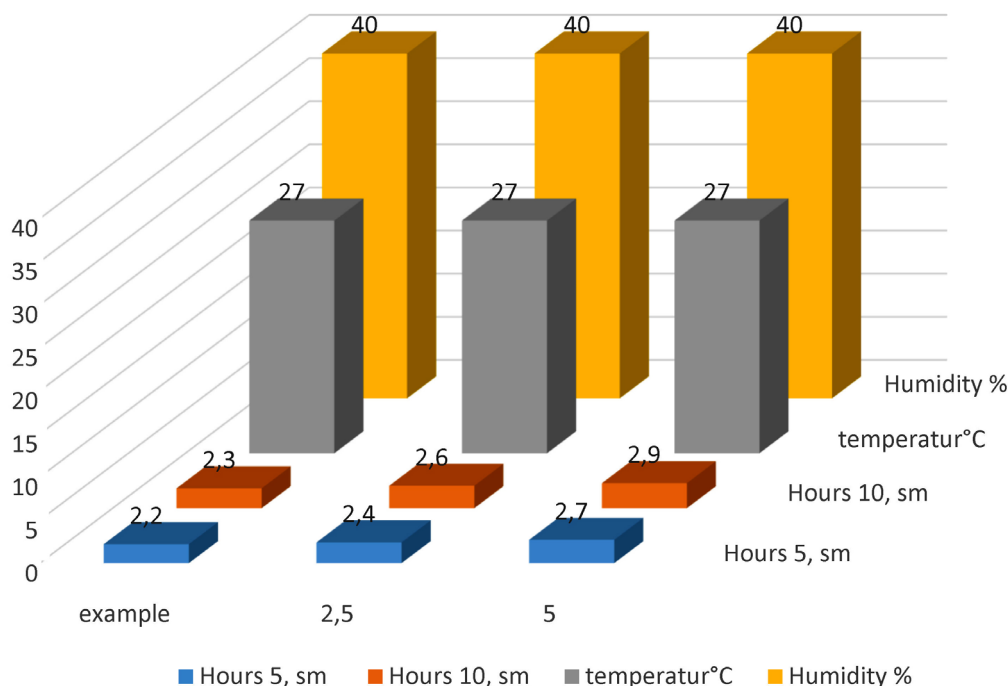

Conclusion

Cobalt is necessary for plants to absorb molecular nitrogen, it is a trace element, the nodes of legumes and the formation of nodular bacteria on the leaves will give. Cobalt accumulates in the wood of the plant and accelerates growth, participates in the metabolism of oxsin, that is, an important nutrient for plant growth processes, including cell membranes, helps to lengthen. This metal ion is involved in the proliferation of leaf cells.

An increase in the thickness and volume of mesophilic, columnar and cell volume in the turbid-leaf parenchyma. In addition, cobalt is a common water for plants. increases the maintenance and, consequently, the drought of crops increases the longevity. The concentration of chloroplasts and pigments in the leaves, the formation of the photosynthetic apparatus of plants and the effect of the coordination of cobalt compounds is very important.

References

- Sapaev, J. Growing of pleurotus ostreatus mushrooms under the artificial light and its influence on d-vitamin content // IOP Conference Series: Materials Science and Engineering. – IOP Publishing, 2020. – V. 883. – No. 1. – 012127 p.
- Gulbakhar Baymuratova, Khasan Nasimov and Foziljon Saitkulov. Synthesis of 6-benzylaminopurine and the study of biological active properties of cotton C-6424 plants. E3S Web of Conf., – 389. (2023). – 03032 p.
- Saitkulov, F. E., Tashniyazov, A. A., Mamadrahimov, A. A., & Shakhidoyatov, K. M. (2014). – 2, 3-Dimethylquinazolin-4 (3H)-one. *Acta Crystallographica Section E: Structure Reports Online*, – 70(7). – o788-o788.
- Sapaev, B., Saitkulov, F. E., Tashniyazov, A. A., & Normurodov, O. U. (2021). Study of methylation reactions of 2-phenylquinazoline-4-tion with “soft” and “hard” methylation agents and determination of its biological activity. In *E3S Web of Conferences* (Vol. 258, p. 04023). EDP Sciences.
- Sapaev, B., Sapaev, I. B., Saitkulov, F. E., Tashniyazov, A. A., & Nazaraliev, D. (2022, June). Synthesis of 2-methylquinazoline-4-thione with the purpose of alkylation of 3-propyl

- 2-methylquinazoline-4-thione with alkylating agents. In *AIP Conference Proceedings* (Vol. 2432, No. 1). AIP Publishing.
- Baymuratova, G., Nasimov, K., & Saitkulov, F. (2023). Synthesis of 6-benzylaminopurine and the study of biological active properties of cotton C-6424 plants. In *E3S Web of Conferences* (Vol. 389, p. 03032). EDP Sciences.
- Khatamov, K., Saitkulov, F., Ashurov, J., & Shakhidoyatov, K. (2012). 3, 5, 6-Trimethylthieno [2, 3-d] pyrimidin-4 (3H)-one. *Acta Crystallographica Section E: Structure Reports Online*, – 68(9), o2740-o2740.
- Foziljon Saitkulov, Bairamdurdi Sapaev, Khasan Nasimov, Dilorom Kurbanova and Nargiza Tursunova. Structure, aromatic properties and preparation of the quinazolin-4-one molecule. *E3S Web of Conf.*, – 389. (2023). – 03075 p.
- Bairamdurdi Sapaev, Foziljon Saitkulov, Muattar Mamedova, Shahlo Saydaliyeva and Dilafroz Makhmudova. Chromato-mass-spectrometry of the analysis of the sum of the common mushrooms 01006 Published online: 04 September 2023.
- Сайткулов, Ф. Э., Элмурадов, Б. Ж., & Гиясов, К. (2023). Алкилирования хиназолин-4-она «мягким» и «жестким» алкилирующими агентами. *Universum: химия и биология*, (1–2 (103)), – P. 53–56.
- Saitkulov, F., Qilichyeva, N., Abdullayev, B., Anvarov, A., & Ergasheva, M. (2022). Titrimetric analysis of calcium cation in "megaton" variety of cabbage. *International Bulletin of Applied Science and Technology*, –2(10). – P. 134–135.
- Saitkulov, F., Farhodov, O., Olishева, M., Sapparboyeva, S., & Azimova, U. (2022). Chemical feeding method of lemon plant using leaf stomata. *Академические исследования в современной науке*, – 1(17). – P. 274–277.
- Boymuratova, G. O., Saitkulov, F. E., Nasimov, K. M., & Tugalov, M. (2022). To Examine the Processes of Biochemical Action Of 6-Benzylaminopurine with Cobalt-II Nitrate Dihydrate on the "Morus Alba" Variety of Moraceae Plant. *Eurasian Journal of Physics, Chemistry and Mathematics*, – 3, – P. 39–42.
- Murodilayevich, K. M., Shoyimovich, K. G., & Ergashevich, S. F. (2022). Chromato-Mass Methods for Detecting Simple Esters in Chromatography-Mass Spectrometry Method. *international journal of biological engineering and agriculture*, – 1(6). – P. 53–56.
- Сайткулов, Ф. Э. (2022). Гиясов Кучкар, Элмурадов Бурхон Жураевич Метилирование 2-метилхиназолин-4-она «мягкими» и «жесткими» метилирующими агентами. *Universum: химия и биология*, (11–2), – 101 p.
- Saitkulov, F., Begimqulov, I., O'ralova, N., Gulimmatova, R., & Rahmonqulova, D. (2022). Biochemical effects of the coordination compound of cobalt-II nitrate quinazolin-4-one with 3-indolyl acetic acid in the "amber" plants grades PHASEOLUS AUREUS. *Академические исследования в современной науке*, – 1(17). – P. 263–267.
- Saitkulov, F., Elmurodov, B., O'lmasova, K., & Alijonova, A. (2023). preparation of a mixed coordination compound cobalt-ii nitrate hexahydrate with quinazoline-4-one and 3-indolylacetic acid on "amber" plants of the phaseolus aureus variety. *Science and innovation in the education system*, – 2(1). – P. 81–87.
- Bairamdurdi Sapaev, Foziljon Saitkulov, Muattar Mamedova, Shahlo Saydaliyeva and Dilafroz Makhmudova. Chromato-mass-spectrometry of the analysis of the sum of the common mushrooms. *BIO Web Conf.*, – 65. (2023). – 01006 p.

submitted 12.01.2024;

accepted for publication 31.01.2024;

published 18.03.2024

© Baymuratova G.O', Saitkulov F. E.

Contact: saitulovfoziljon@gmail.com

DOI:10.29013/AJT-24-1.2-19-23



CHEMICAL COMPOSITION AND CLASSIFICATION OF CHEWING GUM ACCORDING TO COMMODITY NOMENCLATURE FOREIGN ECONOMIC ACTIVITY THE REPUBLIC OF UZBEKISTAN

*Kurbonkul Karimkulov*¹, *Ikromjon Uzahkov*², *Muzaffar Karimkulov*³,

¹ Technical Sciences, Customs Institute of the Customs Committee, Uzbekistan, Tashkent

² Almalyk branch of Tashkent State Technical University, Uzbekistan, Tashkent

³ Synergy University Dubai, UAE

Cite: Karimkulov K., Uzahkov I., Karimkulov M. (2024). Chemical Composition and Classification of Chewing Gum According to Commodity Nomenclature Foreign Economic Activity the Republic of Uzbekistan. Austrian Journal of Technical and Natural Sciences 2023, No 11-12. <https://doi.org/10.29013/AJT-24-1.2-19-23>

Abstract

In this article, types of chewing gum are analyzed, their chemical composition is studied, and classification criteria according to the Commodity Nomenclature of Foreign Economic Activity are developed and recommended for customs practice. It was established that the amount of vitamins in the studied samples of chewing products is less than the regulatory requirements, and the amount of vitamins in some samples is more than the norm, i.e. 2.5 times more, and harmful dyes such as E171, E170, E903 were also detected more than normal.

Keywords: Chewing gum, Commodity nomenclature for foreign economic activity, assortment of chewing gum, classification, chemical composition

Introduction

The origin of chewing gum goes back to the distant past, that is, the first mention of it appeared 5000 years ago in Ancient Greece. The Greeks, as well as the inhabitants of the Near East, washed their teeth by chewing rubber and mastic resin, and this product can be called the first prototypes of chewing gum.

But the origin of chewing gum, which is approximately similar to the real one, dates back to 1848. Of course, it is very different from the modern one. The base of the gum, the composition – everything was made of rubber, and it looked different.

Its creator was John Curtis – an Englishman who created gum from resin with the addition of beeswax. He cut it into small pieces, wrapped it in paper and sold it. Some time later, Curtis added spices and kerosene to his invention, which gave the gum its flavor. Although all this did not save the situation where the chewing gum could not withstand heat and sunlight and lost its presentation in a short time.

The composition of the chewing gum, which was very primitive, underwent some changes only in 1884. Improved chewing gum was developed by Thomas Adams.

His first gum had an elongated shape and a licorice flavor, but the product was short-lived. The problem was solved by adding sugar and corn syrup. Since then, chewing gum has gradually evolved into the product we are used to seeing.

Adams was the creator of the first fruit-flavored chewing gum called Tutti Frutti. This gum is still produced today.

In 1892, the still famous Wrigley's Spearmint chewing gum appeared, created by Wil-

liam Wrigley. In addition, he improved the technical production of the product – the chewing gum itself, its composition, underwent changes: the shape was expressed in the form of a plate or ball, and components such as powdered sugar and fruit additives were added.

Gum's chemical components

At the beginning of the last century, chewing gum manufacturers developed a single formula for what real chewing gum should be.

Table 1. *The chemical composition of Chewing gum*

Substance	Percentage	Procent
Sugar		60%
Rubber		20%
Aromatic Ingredients		1%
Corn syrup		19%

Modern manufacturers produce their products in the following composition:

1. Chewing base.
2. Aspartame.
3. Starch.
4. Coconut oil.
5. Various paints.
6. Glycerin.
7. Natural and artificial flavors.
8. Technical ionol.
9. Acids: apple and lemon.

Such a composition raises doubts about the usefulness of chewing gum. But without chemical components, modern chewing gum cannot retain its taste for a long time and cannot be stored for a long time.

The benefits of chewing gum

Although the use of chewing gum is the cause of many debates about its benefits and harms, nevertheless, this does not reduce its relevance. Chewing this product brings its benefits to people. The gum makes your breath fresh and pleasant.

Regular chewing helps strengthen the gums. This is true, but for this you need to chew equally on both sides of the mouth, otherwise you can achieve the development of facial asymmetry. Maintains the acid-base environment of the oral cavity.

Gum damage

Every day, hundreds of thousands of people, maybe even more, chew gum without

thinking about its effects on the body. But chewing gum can be harmful.

Regular use prevents the normal production of saliva. The amount of saliva increases quantitatively and this is a negative deviation from the norm.

Do not chew gum on an empty stomach. This can lead to the production of gastric juice, which irritates the walls of the stomach and eventually leads to gastritis.

Although chewing gum strengthens the gums, it can have a negative effect on the gums. As a result, blood circulation may be impaired, which leads to inflammation or periodontal disease.

Recently, scientists have found that regular chewing of gum contributes to delayed reaction and deterioration of mental abilities.

If you have fillings on your teeth, chewing gum can cause them to fall out.

Chemical carcinogens have a negative effect on the body, including the development of various diseases. First of all, the gastrointestinal tract can be affected.

In the composition of the gum

Normal chewing gum – “jevachka” contains 7 types of additives:

1. Gum yeast The main ingredient of gum is: rubber, telastomer, tree glue, binel polymer, paraffin.

2. Sweeteners: there are 7 types, and because they are not natural, they all disrupt the digestion in the stomach and intestines, and

prepare the ground for diabetes. In addition, some sweeteners, such as aspartom, disrupt brain activity, cause dizziness and fainting.

Swelling of the lips, tongue and feet. Aspartom contains an amino acid called phenylalanine, and its metabolic residues accumulate in the blood and urine. It affects many developing organs and brains of children.

3. There are three fragrances close to nature, and gene technology is the main fragrance.

4. Humectant – glycerol. Pig fat is most likely from livestock products. It is done on the basis of gene technology and non-technology.

5. Emulsifier – lecithin, mainly pork product. Plant-based emulsifier is made from genetically modified beans.

6. There are two types of glossing substances, “shellac” – obtained from genetically modified plants, which leads to allergies, “carnauba wax” – synthetic wax. It is used in the paper and furniture industry.

7. Van am retainer titanium dioxide, which gives color. E-171 is one of the main substances used in nanotechnology, nanoparticles. One of the main substances used in nanotechnology is nanoparticles. Because it is strong, it affects the body’s water exchange.

What chemical additives are included in the composition of “Orbit”?

Orbit is a chewing gum that contains various artificial fillers. However, this manufacturer is very popular, which explains the popularity of the product it produces.

If you read the contents of Orbit chewing gum on the back of the package, you can see the following items:

- Chewing base – polymer latex.
- Sweet taste components – maltitol E965, sorbitol E420, mannitol E421, aspartame E951, acesulfame K E950.
- Various natural and artificial flavors depending on the intended flavor of the gum.
- Coloring substances: E171 – titanium dioxide, gives a snow-white color to the chewing gum.
- Additional components: emulsifier E322 – soy lecithin, antioxidant E321 – artificial substitute for vitamin E

that inhibits oxidation, sodium bicarbonate E500ii, thickener E414, emulsifier and defoamer, stabilizer E422, glaze E903.

Orbita is also available without sweeteners. The composition of sugar-free Orbit chewing gum is the same as regular chewing gum, only it contains sweeteners: xylitol, sorbitol and mannitol.

“Dirol”: component composition

Dirol is another well-known chewing gum manufacturer. The components it’s made from are different from those used for the Orbit, but there are still some similarities.

The composition of Dirol gum:

- Chewing base – polymer latex.
- Sweeteners – isomalt E953, sorbitol E420, mannitol E421, maltitol syrup, acesulfame K E950, xylitol, aspartame E951.
- Flavoring additives depend on the expected flavor of the gum.
- Dyes – E171, E170 (calcium carbonate 4%, white paint).
- Additional elements – emulsifier E322, antioxidant E321 – artificial replacement of vitamin E, which helps to inhibit oxidation processes, stabilizer E441, texturizer E341iii, thickener E414, emulsifier and defoamer, stabilizer E422, glaze E903.

E422 causes intoxication of the body when it enters the bloodstream.

E321 increases the level of bad cholesterol.

E322 increases the production of saliva, which subsequently has a negative effect on the gastrointestinal tract.

Citric acid can cause swelling.

Gum “Eclipse”

The composition of Eclipse gum is as follows:

- Base – latex.
- Sweeteners – maltitol, sorbitol, mannitol, acesulfame K, aspartame.
- Fragrances are natural and the same as natural. They depend on the taste of the gum.

Dyes – calcium carbonate 4%, E171, blue dye, E132.

Additional substances – E414 (gum arabic), stabilizer E422, glaze E903, antioxidant E321.

Chewing gum “Freshness Avalanche”

Avalanche of Freshness gum is sold in the form of small balls of blue, blue and green colors.

This gum is sold by weight, not in multi-piece packs. But mainly, the sale of such chewing gum is carried out with the help of special machines – by pieces.

The composition of Avalanche of Freshness chewing gum has the following composition: latex, sugar powder, caramel syrup, glucose, bubble gum and menthol aroma, shiny blue and sea wave coloring components, E171, E903.

The USA, Russia and Brazil are the countries that export the most chewing gum products (Fig. 1).

Figure 1. Countries that export the most gum

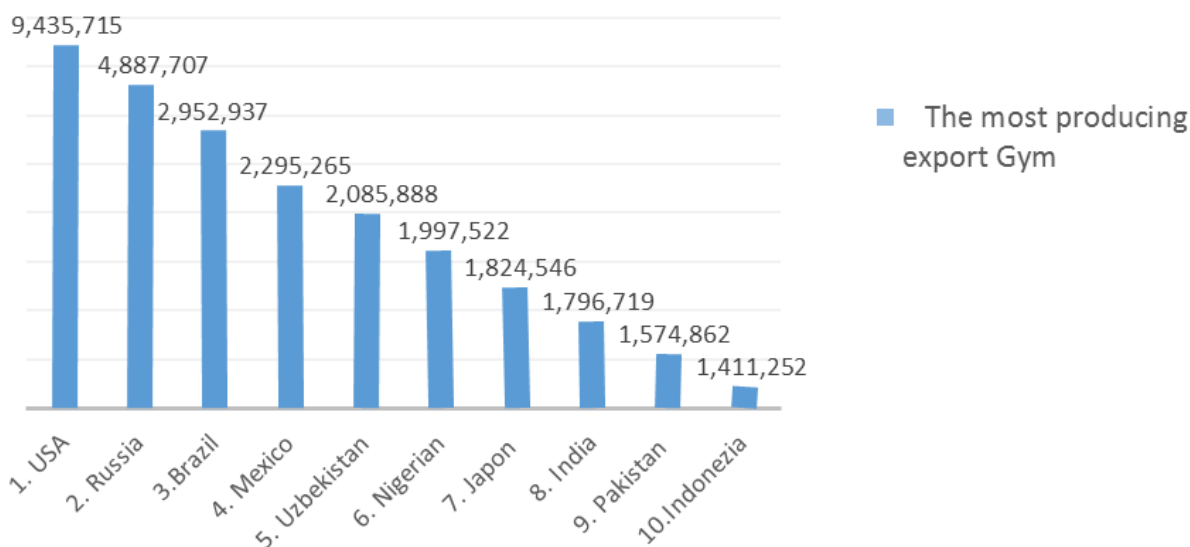
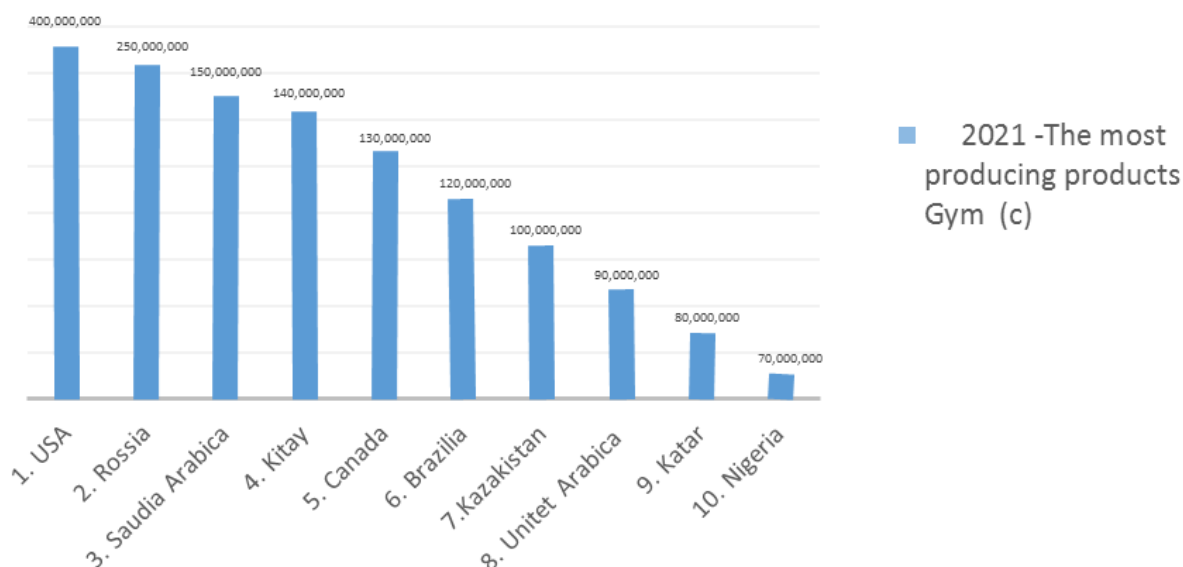

Figure 2. Gum producing countries



Information on the most producing countries (Figure 2) is also provided.

Chewing gum is located in group 09 of commodity nomenclature foreign economic

activity according to types and level of processing.

+ 2106 90980 1 sugar-free chewing gum sugar-free chewing gum (sucrose) with sugar substitute

– 2106 90980 2 – – – – chewing gum without sugar (semi-finished product) is included in the product subheadings like others. Also refer to the Notes of group 21, ispolzuyemye v kachestve lekarstvennykh sredstv, ili prochie produkti tovarnoy positsii 3004; can be Group 3004 See explanation, + 3004 60000 0 – other, containing antimicrobial active (deystvuyushchie) substances, indicated in the subposition of 2 data groups. In order to identify types of Jevatelnaya rezinkan in commodity groups 2106 and 3004, classification criteria were developed and put into customs practice.

Conclusion

Thus, in our research work, the chemical composition of Chewing gum species was studied and the criteria for their identification and classification in commodity groups 2106 and 3004 according to commodity nomenclature foreign economic activity ac were developed and recommended for customs practice. It was found that in the studied Chewing gum products, vitamins are less than the standard requirements, one sample contains more vitamins than the standard, i.e. 2.5 times more, and it also contains various poisonous crystals E171, E903.

References

- Andreeva, E. I. Development of methodology and improvement of the mechanism for managing the identification of goods for customs purposes: Monograph / E. I. Andreeva. M.: RIO Russian Customs Academy, 2016.– 202 p.
- Gail, L. Kramer, Clarence, W. Jensen, Douglas, D. Southgate Jr. Agricultural economics and agribusiness.– New York, 2001.– 519 p.
- Gibilisko, S. Alternative energy without secrets / Stan Gibilisko; [transl. from English A. V. Solovyova].– M.: Eksmo, 2010.– 368 p.– (No secrets).
- Shalygina, A. M., Kalinina, L. V. General technology of milk and dairy products.– Moscow: Colossus, 2006.– P. 180–182.
- Dodaev, K. O., Absalyamov, F. M., Begmatov, A. B. Tuya sutuningshifobakhshlikhususiyati // “Kimevaozik-ovkat mxsulotlarining sifati hamda havfsizligini taminlashda innovation technologylar”. Mavzusidagi II Republic Ilmiy Amaliy-Technikaviy Conference Materiallari.– Tashkent, TKTI. (May 17, 2019).– P. 144–145.
- Methods for determining toxic elements // State standards. Raw materials and food products.– Moscow: IPK publishing standards, 2002.– P. 50–70.
- Ibragimov, U. K. Evaluation of antioxidants – food additives // STANDART, 2002.– No. 1.– P. 58–59.
- Karimkulov, K. M., Uzohkov, I. E., Sarikulov, M. K. Studying The Classification and Quality of Food // The American Journal of Agriculture and Biomedical Engineering, 2021.– Vol. 03.– Issue 03–06.– P. 32–38.

submitted 26.01.2024;

accepted for publication 12.02.2024;

published 18.03.2024

© Karimkulov K., Uzahkov I., Karimkulov M.

Contact: karimkulov@mail.ru

DOI:10.29013/AJT-24-1.2-24-27



CYCLOASCIDOSIDE D FROM *ASTRAGALUS MUCIDUS*

Artikbaeva Baxtibike Rasbergenovna¹, Naubeev Temirbek Khasetullaevich¹

¹Department “Oil & Gas Technology”, Karakalpak State University

Cite: Artikbaeva B.R., Naubeev T.Kh. (2024). Cycloascidoside D from *Astragalus Mucidus*. *Austrian Journal of Technical and Natural Sciences* 2023, No 11-12. <https://doi.org/10.29013/AJT-24-1.2-24-27>

Abstract

A new cycloartane glycoside, cycloascidoside D which is determined as 3-O-β-D-(2-OAc)-xylopyranoside-24R-cycloartane-3β,6α,16β,24, 25-pentaol, was isolated from the aerial part of the plant *Astragalus mucidus* Bunge (Leguminosae).

Structure of this glycoside was proven by chemical transformations and on the basis of ¹H and ¹³C NMR spectra, which were interpreted using 2D NMR.

Keywords: Triterpenoids, cycloartanes, cycloasgenin C, glycosides, cycloascidoside D, Leguminosae, *Astragalus*, ¹H, ¹³C NMR spectra, HMBC

Introduction

In continuation of our studies of cycloartane triterpenoids from plants of the genus *Astragalus* (Leguminosae) (Naubeev, T. Kh., Uteniyazov, K. K., Isaev, M. I., 2011). We determined the structure of a new cycloartane glycoside, cycloascidoside D (**1**), obtained from the aerial part of *Astragalus mucidus* Bunge. Its structure is discussed in the article.

The ¹H NMR spectrum of cycloascidoside D shows single-proton doublets of the AX system at 0.29 and 0.58 ppm with SSCC2J = 4.5 Hz along with signals of seven methyl groups in the range of 1.05–1.86 ppm, allowing us to classify the compound under discussion as triterpenoids of the cycloartane series (Naubeev, T. Kh., Uteniyazov, K. K., Isaev, M. I., 2011; Naubeev, T. Kh., Zhanibekov, A. A., Isaev, M. I., 2012; Naubeev, T. Kh., Zhanibekov, A. A., Uteniyazov, K. K., Bobakulov, Kh. M., Abdullaev, N. D., 2014;

Naubeev, T. Kh., Ramazonov, N. Sh., 2021; Naubeev, T. Kh., Uteniyazov, K. K., Ramazonov, N. Sh., 2022).

Indeed, genin **2**, identified with cycloasgenin C, was isolated from the products of acid hydrolysis of glycoside **1** (Naubeev, T. Kh., Uteniyazov, K. K., Isaev, M. I., 2011; Naubeev, T. Kh., Zhanibekov, A. A., Isaev, M. I., 2012).

D-xylose was detected in the carbohydrate part of the acid hydrolyzate after neutralization and concentration by paper chromatography (PC). The presence of signals of one anomeric proton and one anomeric carbon atom at 4.64 ppm and 104.92 ppm in the ¹H and ¹³C NMR spectra suggests that the discussed compound **1** is of glycosidic nature and is a monoside. A set of chemical shifts of carbon and hydrogen atoms, as well as the coupling constant of protons of the monosaccharide residue indicate the pyranose form,

4C_1 -conformation and β -configuration of D-xylose. The same conclusion emerges from the chemical shifts of the corresponding carbon atoms. Comparative analysis of the ^{13}C NMR spectra of the new glycoside **1** and cycloasgenin C unambiguously determines the position of D-xylose at C-3.

Chemical correlation in the HMBC spectrum of the glycoside was observed between

the signals of H-3 (δ 3.66 ppm) and the anomeric carbon atom of D-xylose (δ 104.92 ppm), as well as between the signals of the anomeric proton of the monosaccharide (δ 4.64 ppm) and the C-3 atom (δ 89.20 ppm) of the aglycone.

These facts also indicate the location of D-xylose at C-3.

Figure 1. Acid and alkaline hydrolysis of cycloascidoside D (**1**)

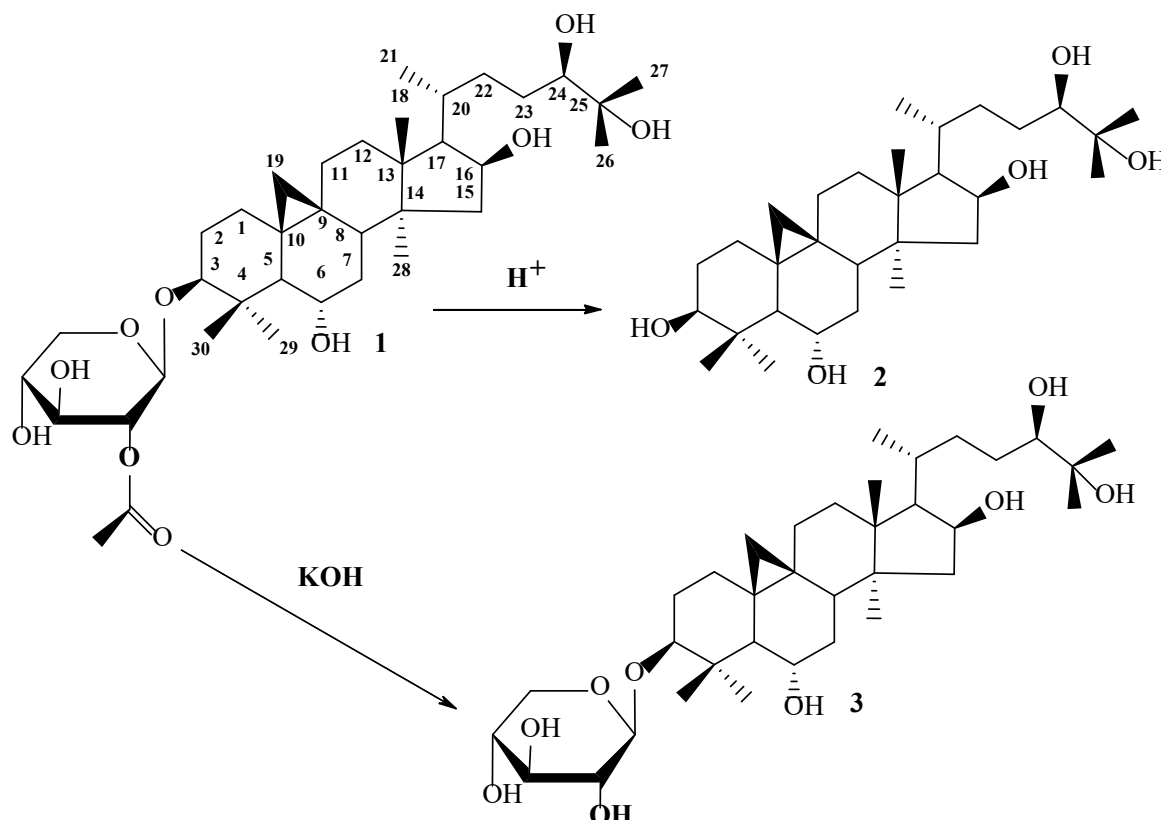

In the 1H NMR spectrum of the glycoside there is **1** three-proton singlet at 2.02 ppm indicates that this glycoside contains one acetyl group. As expected, the ^{13}C NMR spectrum of new glycoside **1** shows signals from the carbon atoms of one acetyl group at 21.23 and 170.02 ppm.

Alkaline hydrolysis of cycloascidoside D leads to the formation of glycoside **3**, iden-

tified with 3-O- β -D-xylopyranoside cycloasgenin C (Naubeev, T. Kh., Uteniyazov, K. K., Isaev, M. I., 2011; Naubeev, T. Kh., Zhanibekov, A. A., Isaev, M. I., 2012; Naubeev, T. Kh., Zhanibekov, A. A., Uteniyazov, K. K., Bobakulov, Kh. M., Abdullaev, N. D., 2014). The place of the attachment of the acetyl group was determined by comparative study of the ^{13}C NMR and 1H spectra and compounds **1** and **3**.

Table 1. Chemical shifts of carbon atoms of compounds **1** and **3** (C_5D_5N , δ , ppm, J/Hz, 0-TMS)

C/H	δ_c	1 δ_H	3 [2] δ_c	C/H	δ_c	1 δ_H	3 [2] δ_c
1	32.95	1.22 m, 1.65 m	32.97	20	32.10	1.92 m	32.11
2	30.85	2.50 m, 1.93 m	30.85	21	19.44	1.12 d (6.3)	19.46

C/H	δ_c	1 δ_H	3 [2] δ_c	C/H	δ_c	1 δ_H	3 [2] δ_c
3	89.20	3.66 dd (11.5, 4.4)	89.20	22	35.30	1.26 m, 2.38 m	35.31
4	43.18	–	43.20	23	29.82	1.85 m; 1.95 m	29.86
5	54.60	1.76 d (8.7)	54.61	24	81.07	3.80 q	81.07
6	68.38	3.75 td (9, 9, 3.8)	68.40	25	73.14	–	73.16
7	38.92	2.17 dt (13.1, 4, 4)	38.93	26	26.41	1.53 s	26.41
8	47.48	1.99 dd (9.8, 5.2)	47.50	27	26.62	1.50 s	26.64
9	21.82	–	21.84	28	20.69	1.04 s	20.70
10	29.69	–	29.71	29	29.34	1.86 s	29.36
11	26.76	1.70 m, 1.24 m	26.79	30	17.17	1.36 s	17.18
12	33.61	1.68 m,	33.64	β-D-Xylp			
13	46.18	–	46.19	1	104.92	4.64 d (7.5)	108.12
14	47.39	–	47.41	2	76.65	5.36 dd (8.6, 7.8)	76.13
15	49.19	1.97 dd (5.2, 12); 2.44 dd (8, 12)	49.20	3	75.59	3.97 t (8.7)	79.02
16	72.16	4.53 td (7.5, 7.5, 4.8)	72.20	4	71.73	4.17 t (9)	71.74
17	57.67	1.72 m	57.70	5	67.56	3.68 dd (11.3, 10); 4.38 dd (11.2, 5.1)	67.55
18	19.24	1.41 s	19.27	Ac	21.23	2.02 s	
19	30.43	0.28 and 0.58 dd (4.5)	30.46	Ac	170.02		

The C-6, C-16, C-25 atoms of the glycoside **1** molecule in the ^{13}C NMR spectrum resonate at 68.38, respectively 72.17 and 73.14 ppm. These values practically coincide with those of the ^{13}C NMR spectra of cycloasgenin C and glycoside **3**. Consequently, the acetyl group is not located in the genin part of the cycloascidoside D molecule. Indeed, a one-proton doublet with a coupling constant of $^3J_1 = 9$ and $^3J_2 = 8$ Hz is noted in the ^1H NMR spectrum of the latter at 5.36 ppm, belonging to the proton geminal to the acetyl group.

Additional confirmation of the conclusion about the position of the acetyl group is provided by a comparative analysis of the ^{13}C NMR spectra of glycosides **1** and **3**.

As can be seen from Table 1, upon transition from glycoside **3** to glycoside **1**, the chemical shifts of carbon atoms C-1 (–2.84 ppm), C-2 (+0.52 ppm), C-3 (–2.87) of monosaccharide residue change significantly. The signs and values of these changes coincide well with the α - and β -influences of the acetyl group located at C-2 of the β -D-xylopyranoside ring, and unambiguously determine the location of the acetyl residue.

Thus, the presented experimental data allow us to conclude that the new triterpene glycoside of the cycloartane series, cycloascidoside D, has the structure 3-O- β -D-(2-OAc)-xylopyranoside-24R-cycloartane-3 β ,6 α ,16 β ,24,25- pentaol.

Experimental part. General Experimental Procedures (Naubeev, T. Kh., Uteniyazov, K.K., Isaev, M.I., 2011). The following solvent systems were used: 1) chloroform-methanol (9:1), 2) chloroform-methanol-water (70:12:1), 3) chloroform-methanol-water (70:23:3).

NMR spectra were recorded on a JNM-ECZ600R spectrometer (JEOL, Japan) at an operating frequency of 600 MHz, for ^1H in $\text{C}_5\text{D}_5\text{N}$ solutions. TMS (0 ppm) was used as an internal standard in ^1H NMR spectra. In the ^{13}C NMR spectra, the chemical shift of the solvent ($\text{C}_5\text{D}_5\text{N}$, 150.35 ppm relative to TMS) was used as an internal standard.

Extraction and isolation. Isolation method of isoprenoids from the aerial parts *Astragalus mucidus* Bunge were given in (Naubeev, T. Kh., Uteniyazov, K.K., Isaev, M.I., 2011). When the column was eluted with a 70:12:1 system (chloroform-methanol-wa-

ter), 84 mg of cycloascidoside D was isolated (0.0056%, the yield here and below is given based on the weight of air-dried raw material).

Cycloascidoside D (1) – substance 1, $C_{37}H_{62}O_{10}$, m.p. 260–262°C (from methanol).

Acid hydrolysis of cycloascidoside D. Glycoside 1 (35 mg) was dissolved in 15 ml of a 0.5% methanol solution of sulfuric acid and boiled in a water bath for 1 hour, monitoring the progress of hydrolysis on TLC every 20 minutes. Then the reaction mixture was diluted with a threefold volume of water and the methanol was evaporated. The formed precipitate was filtered off, washed with water, and dried. The filtrate was neutralized with $BaCO_3$. After removing the precipitate, the solution was concentrated and D-xylose was found by using PC in the system n-butyl alcohol-pyridine-water (6:4:3) in comparison with known samples.

The residue was chromatographed on a column, eluting with a system 1. 10 mg of genin 2, identified with cycloasgenin C $C_{30}H_{52}O_5$, m.p. 250–252°C (from methanol), which was identified as a true sample according to the 1H and ^{13}C NMR spectrum and mobility on TLC.

1H NMR spectrum of cycloasgenin C (400 MHz, C_5D_5N , δ , ppm, J/Hz, 0-HMDS): 0.21 and 0.49 (d, J=4, 2H-19), 0.92 (CH_3 , s), 1.00 (d, J=6.4, CH_3 -21), 1.25, 1.30, 1.36, 1.39, 1.77 (s, $5 \times CH_3$), 3.55 (dd, J=11.4, 4.7, H-3), 3.67 (dd, J=10.4, J=2.3, H-24), 3.69 (td, J=9.4, 3.7, H-6), 4.60 (td, J=7.8, 5.0, H-16) (Naubeev, T. Kh., Uteniyazov, K.K., Isaev, M.I., 2011).

Alkaline hydrolysis of cycloascidoside D. 25 mg of cycloascidoside D (1) was saponified with 20 ml of 0.5% methanol solution of potassium hydroxide. The reaction mixture was left at room temperature for a day. Then the methanol solution was diluted with a threefold volume of water, and the methanol was evaporated. The reaction product was extracted with butanol. The butanol extract was washed with water. The dry residue after distilling off the butanol was chromatographed on a silica gel column. Eluting with system 2, 15 mg of glycoside 3 was isolated, m.p. 252–254°C (from methanol), identified with 3-O- β -D-xylopyranoside cycloasgenin C (3) (Naubeev, T. Kh., Zhanibekov, A.A., Isaev, M.I., 2012).

1H NMR spectrum of 3-O- β -D-xylopyranoside cycloasgenin C (3) (600 MHz, C_5D_5N , δ , ppm, J/Hz, 0-HMDS): 0.30 and 0.58 (2H-19, d, $^2J=4$), 1.05 (CH_3 , s), 1.13 (CH_3 -21, d, $^3J=6.4$), 1.36, 1.42, 1.51, 1.53, 2.02 ($5 \times CH_3$, s), 3.60 (H-5a of β -D-xylopyranose residue, dd, $^2J=11.2$, $^3J=9.8$), 3.64 (H-3, dd, $^3J_1=11.7$, $^3J_2=4.6$), 3.67 (H-6, td, $^3J_1=^3J_2=9.7$, $^3J_3=3.6$), 3.75 (H-24, dd, $^3J_1=10.5$, $^3J_2=2.4$), 3.83 (H-2 β -D-xylopyranose residue, dd, $^3J_1=8.8$, $^3J_2=7.5$), 4.06 (H-3 β -D-xylopyranose residue, t, $^3J_1=^3J_2=8.6$), 4.15 (H-4 of β -D-xylopyranose residue, m), 4.36 (H-5e of β -D-xylopyranose residue, dd, $^2J=11.3$, $^3J=5$), 4.71 (H-16, td, $^3J_1=^3J_2=7.7$, $^3J_3=4.9$), 4.92 (H-1 of β -D-xylopyranose residue, d, $^3J=7.5$).

^{13}C NMR spectra of the 3-O- β -D-xylopyranoside cycloasgenin C (3) is given in the table 1.

References:

- Naubeev, T. Kh., Uteniyazov, K.K., Isaev, M.I. (2011). *Chem. Nat. Compd.*, – 47.– 250 p.
 Naubeev, T. Kh., Zhanibekov, A.A., Isaev, M.I. (2012). *Chem. Nat. Compd.*, – 48.– 813 p.
 Naubeev, T. Kh., Zhanibekov, A.A., Uteniyazov, K.K., Bobakulov, Kh.M., Abdullaev, N.D. (2014). *Chem. Nat. Compd.*, – 49.– 1048 p.
 Naubeev, T. Kh., Ramazonov, N. Sh. (2021). *Austrian Journal of Technical and Natural Sciences*, – № 7–8.– 48 p.
 Naubeev, T. Kh., Uteniyazov, K.K., Ramazonov, N. Sh. (2022). *Austrian Journal of Technical and Natural Sciences*, – № 7–8.– 42 p.

submitted 07.02.2024;

accepted for publication 26.02.2024;

published 18.03.2024

© Artikbaeva B. R., Naubeev T. Kh.

Contact: timan05@mail.ru



DOI:10.29013/AJT-24-1.2-28-35



SYNTHESIS AND BIOLOGICAL ACTIVITY OF HYDROCHLORID QUINAZOLIN-4-ONE

*Saitkulov Foziljon Ergashevich*¹, *Elmuradov Burkxon Zhuraevich*²,
*Sapaev Bayramdury*³

¹ Tashkent state agrarian universitet of Uzbekistan, Tashkent

² Institute of Chemistry of Plant Substances Academy of Sciences of
the Republic of Uzbekistan, Republic of Uzbekistan, Tashkent

³ Alfraganus University of Uzbekistan, Tashkent

Cite: *Saitkulov F.E., Elmuradov B.Z., Sapaev B. (2024). Synthesis and Biological Activity of Hydrochlorid Quinazolin-4-one. Austrian Journal of Technical and Natural Sciences 2023, No 11-12. <https://doi.org/10.29013/AJT-24-1.2-28-35>*

Abstract

By the interaction of anthranilic acid with formamide, an almost quantitative yield of quinazoline-4-oh was obtained. Optimal reaction conditions were established: temperature 130–140 °C, duration 2 hours. Quinazoline-4-oh hydrochloride was obtained from quinazoline-4-oh by passing hydrogen chloride with 96% yield. These compounds at a dose of 100–150 mg/kg exhibit 92% anthelmintic activity against fascioles common in cattle, sheep and goats.

Keywords: *Formamide, quinazoline-4-one, quinazoline-4-oh hydrochloride fascioliasis, stability of the drug, medamine, albendazole, cattle, sheep and goats, activity against fascioliasis*

Introduction

The government attaches more importance to the further increase of folk medicine. A significant place in these activities has been removed from the chemicalization of agriculture and animal husbandry. The Government drew attention to the need for extensive development of scientific research on the creation of herbicides, fungicides, anthelmintic drugs and drugs for pest control of agricultural crops, the organization and search for industrial production of new pesticides. A number of biologically active drugs are known from derivatives of quinazoline-4-one and its

sulfur analog quinazoline-4-thion (Saitkulov, F.E., Tashniyazov, A.A., Mamadrakhimov, A.A., & Shakhidoyatov, K.M., 2014). Recently, scientists from various countries have led to the creation of a large group of highly effective anthelmintic drugs, among the derivatives of quinazoline-4-one (Sapaev, B., Saitkulov, F.E., Tashniyazov, A.A., & Normurodov, O.U., 2021). Infection with various kinds of helminths is a widespread disease among both humans and animals. The main requirements for new anthelmintic drugs should be considered a high therapeutic index, a wide spectrum of action, ease of administration, in particular, single-dose

treatment and stability of the drug in dosage forms (Sapaev, B., Sapaev, I. B., Saitkulov, F. E., Tashniyazov, A. A., & Nazaraliev, D., 2022; Baymuratova, G., Nasimov, K., & Saitkulov, F., 2023).

Results

It is known from the literature that quinazoline-2,4-dione is synthesized by heating a mixture of anthranilic acid with mochevina at 150–160 °C (Khatamov, K., Saitkulov, F., Ashurov, J., & Shakhidoyatov, K., 2012).

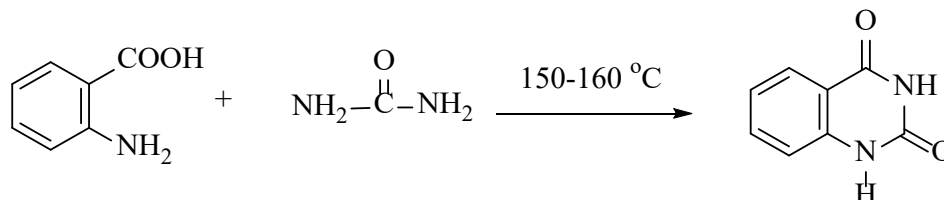

The cyclization reaction of N-methylantranilic acid with sodium cyanate under alkaline conditions resulted in the synthesis of 1-Methylquinazoline-2,4-dione (Foziljon

Saitkulov, Bairamdurdi Sapaev, Khasan Nasimov, Dilorom Kurbanova and Nargiza Tur-sunova, 2023).

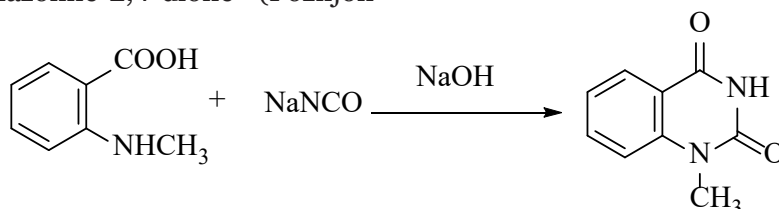

From the reaction of quinazoline-2,4-dione with alkylhalogenides under alkaline conditions, 1,3-dialkylquinazoline-2,4-diones were obtained with high present (A-method)

(Bairamdurdi Sapaev, Foziljon Saitkulov, Muattar Mamedova, Shahlo Saydaliyeva and Dilafruz Makhmudova, 2023).

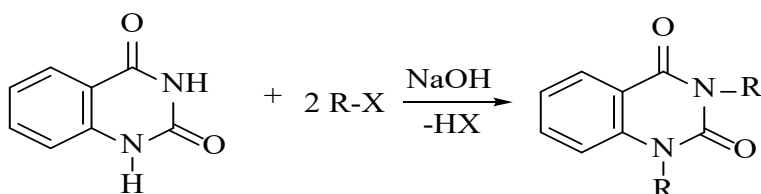

X=Cl, I

R=CH₃, R= n-C₃H₇, R= n-C₄H₉, R= C₆H₅CH₂

It should be noted that under the conditions of interphase catalysis (Сайткулов, Ф. Э., Элмуратов, Б. Ж., & Гиясов, К., 2023).

80–95% oxidation of compounds (B) can be observed in these reactions.

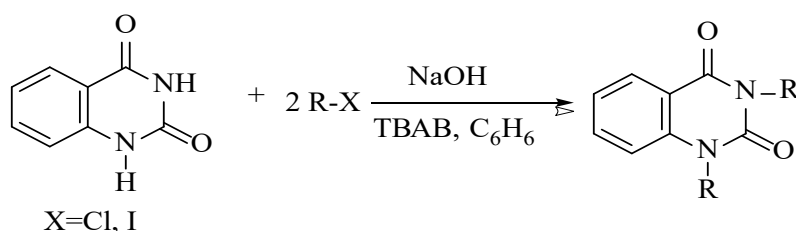

X=Cl, I

Quinazoline-2,4-dione is an equivalent alkylating agent and is formed as a result of the reaction of 1,3-dialkylquinazolin – 2,4-dione to form 1- or 3-monoalkyl mole-

cules (Saitkulov, F., Qilichyeva, N., Abdulla-yevev, B., Anvarov, A., & Ergasheva, M., 2022).

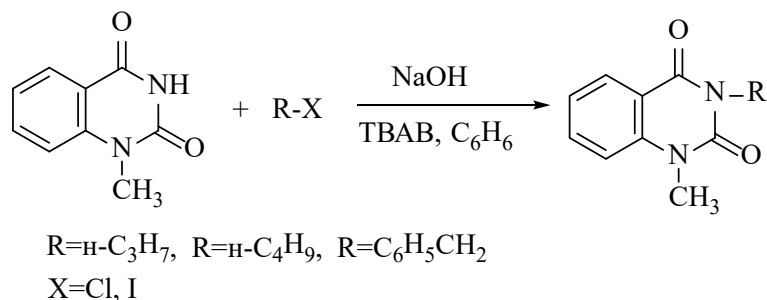

Synthesis of 1-methylquinazoline-2,4-dione alkyl iodides and benzyl chloride of Bilan tetrabutylammonium bromide (TBAB) ishtirok by interphase catalysis in sharoitide (Saitkulov, F., Farhodov, O., Olishева, M., Saparboyeva, S., & Azimova, U., 2022) as a result of alkylation of 1-methyl-3-alkyl(benzyl)quinazoline-2,4-diones not listed in the literature.

There are many works on the synthesis of quinazoline-4-one and its derivatives (Boymuratova, G. O., Saitkulov, F. E., Nasimov, K. M., & Tugalov, M., 2022; Murodilayevich, K. M., Shoyimovich, K. G., & Ergashevich, S. F., 2022; Сaitкулов, Ф. Э., 2022; Saitkulov, F., Begimqulov, I., O'ralova, N., Gulimmatova, R., & Rahmonqulova, D., 2022; Saitkulov, F., Elmuradov, B., O'lmasova, K., & Alijonova, A., 2023; Bairamdurdi Sapaev, Foziljon Saitkulov, Muattar Mamedova, Shahlo Saydaliyeva and Dilafruz Makhmudova, 2023). In most cases, synthesis is carried out from anthranilic acid and its derivatives. Known methods of obtaining quinazoline-4-one it is not simple and affordable. The most widely used method is based on the use of hard-to-reach substances.

Method and Methodology Quinazoline-4-one. Method: A

13.7 g (0.1 mol) of anthranilic acid and 16 ml (0.4 mol) of formamide ($p = 1.13 \text{ g/sm}^3$) were placed in a two-neck flask equipped with a reverse refrigerator.

The reaction mixture was heated in a glycerin bath at 130–135 °C for 2 hours. Af-

ter cooling to room temperature, the reaction mixture was poured into a glass containing crushed ice and left for 6–8 hours at room temperature. The fallen crystals were filtered, dried and recrystallized in water in the presence of activated carbon. Received 10.7 g (73.3%) of quinazoline-4-one.

$$T = 218 \text{ }^\circ\text{C}, R_f = 0.63.$$

Method B. Similar to Method A, a mixture of 13.7 g (0.1 mol) of anthranilic acid and 16 ml (0.4 mol) of formamide ($p = 1.13 \text{ g/cm}^3$) heating the Vood alloy at 130–135 °C for 2 hours and received 13.92 g (96%) of quinazoline-4-one, $T = 218 \text{ }^\circ\text{C}$ $R_f = 0.63$.

Preparation of quinazoline-4-one hydrochloride

To a mixture of 13.7 g (0.1 mol) of quinazoline-4-one and 50 ml of dry acetone, while stirring, hydrogen chloride gas, obtained from 11.7 g (0.1 mol) of sodium chloride and 9.8 g (0.1 mol) of sulfuric acid, was slowly passed through a gas outlet tube for an hour. After removal of the solvent, quinazoline-4-one hydrochloride was isolated with almost quantitative yield, $T = 180\text{--}181 \text{ }^\circ\text{C}$.

The aim of the work was to obtain quinazoline-4-one hydrochloride and laboratory tests for anthelmintic activity.

The synthesis of quinazoline-4-one by the Nimentovsky reaction proceeds when anthranilic acid is heated with an excess of formamide with the cleavage of two water molecules. The low yield in this reaction was tried to explain by its dehydration.

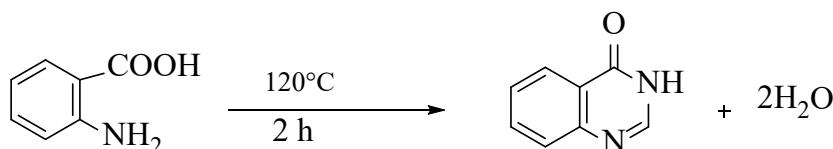

Depending on the reaction conditions, we increased the yield of quinazoline-4-one to 96% by two methods (A and B).

Method A. To obtain the substance quinazoline-4-one, 16 ml (0.4 mol) of formamide ($p = 1.13 \text{ g/sm}^3$) was added to

13.7 g (0.1 mol) of anthranilic acid, and the reaction mixture was heated in a glycerin bath at 130–135 °C for 2 hours. Quinazolin-4-oh was obtained at 72% yields.

Conclusion

In the method, a mixture of anthranilic acid and formamide in a ratio of 1:4 was heated into Vood alloy at 130–135°C for 2. The yield of quinazolin-4-one was 96%. Thus, heating plays an important role in the reaction output (Fig. 1).

Figure 1.

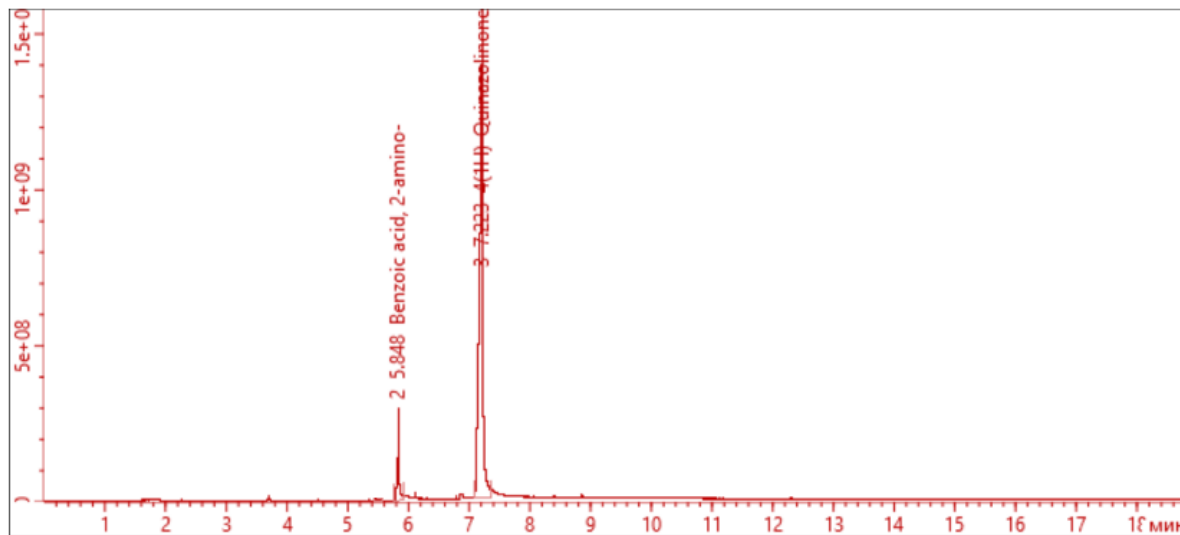

The purity of the product and the course of the reaction were controlled by TLC, Silufol UV-254. (system benzene: acetone 5:3). The melting point of quinazolin-4-oh was determined on the heating table “BOETIUS (Germany)”.

The mass spectrum of quinazolin-4-one was removed by chromatek Crystal with the Chromatek-Crystal 5000 mass spectrometric detector, fully confirm the structure of quinazolin-4-one (Fig-2).

Figure 2.

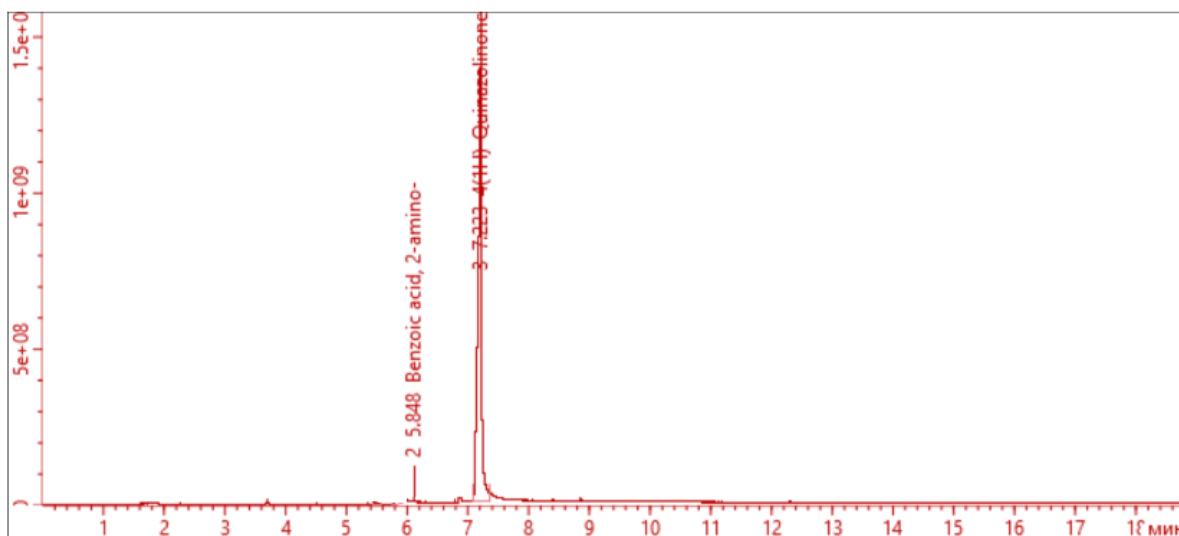

The mass spectrum of quinazolin-4-one is characterized by the presence of an intense peak of the molecular ion. The decay of the molecular ion quinazolin-4-one proceeds with

the elimination of CO and HCN. Further fragmentation of the (M-CO)⁺ ion occurs with the release of two HCN molecules.

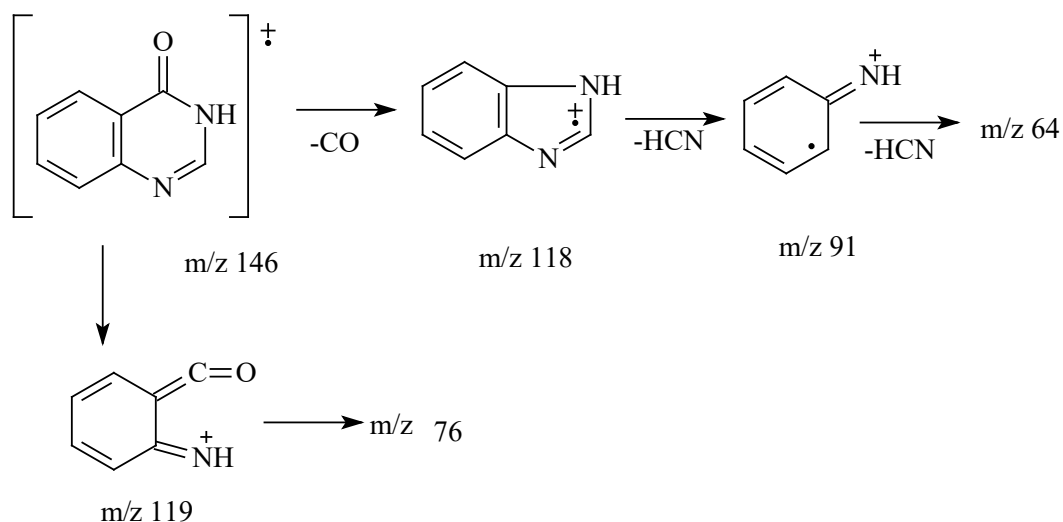

The structure of the quinazolin-4-one molecule is fully consistent with valence angles ^1H NMR spectra.

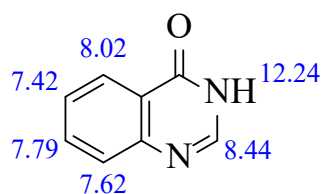

Figure 3.

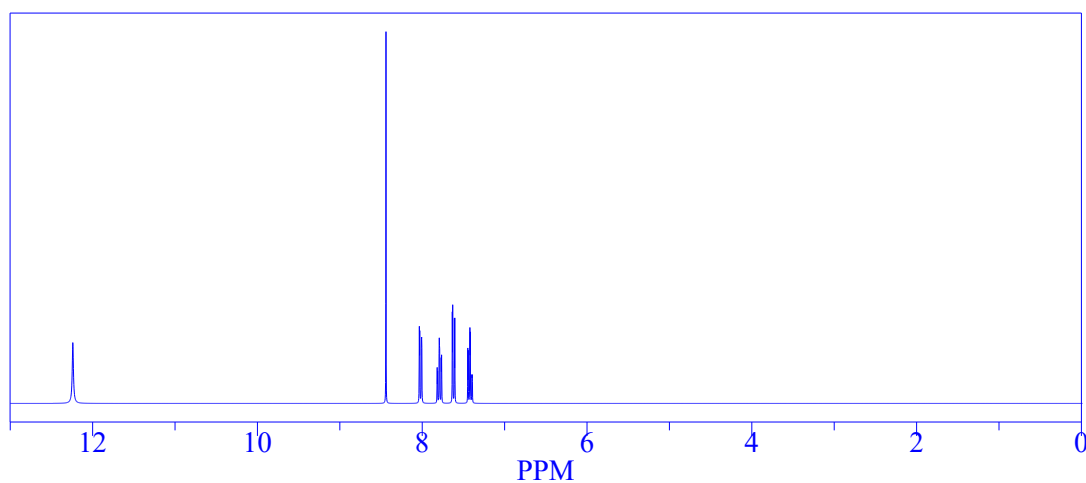
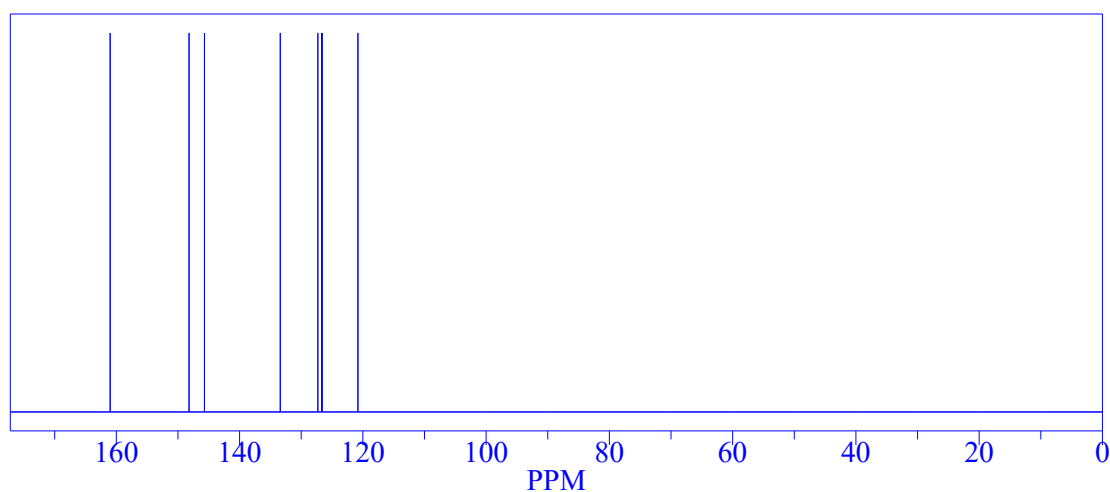

Table 1.

Protocol of the C-13 NMR Prediction: (Lib=S)			
Node	Shift	Base + Inc.	Comment (ppm rel. to TMS)
C	161.0	165.0	1 – amide
		4.7	1–1: C*C*C*C*C*C*1
		?	1 unknown substituent(s) from N-amide
		–8.7	general corrections
CH	145.7	162.8	1–imine
		?	1 unknown substituent(s)
		0.0	1 – C*R from N-imine
		–17.1	general corrections

Protocol of the C-13 NMR Prediction: (Lib=S)			
Node	Shift	Base + Inc.	Comment (ppm rel. to TMS)
C	148.2	128.5	1-benzene
		20.5	1 - N=C
		-1.2	1 - C(=O)-N
		0.4	general corrections
C	120.8	128.5	1 - benzene
		-6.5	1 - N=C
		5.0	1 - C(=O)-N
		-6.2	general corrections
CH	126.7	128.5	1-benzene
		-6.5	1 - N=C
		0.1	1 - C(=O)-N
		4.6	general corrections
CH	126.6	128.5	1 - benzene
		1.3	1 - N=C
		-1.2	1 - C(=O)-N
		-2.0	general corrections
CH	133.4	128.5	1 - benzene
		1.3	1 - N=C
		3.4	1 - C(=O)-N
		0.2	general corrections
CH	127.3	128.5	1 - benzene
		-1.5	1 - N=C
		0.1	1 - C(=O)-N
		0.2	general corrections

Figure 4.



The structure of the quinazoline-4-on molecule is fully consistent with valence angles NMR¹³C spectra.

By passing hydrogen chloride to the acetone solution of quinazoline-4-one, hydrochlorid quinazoline-4-one was obtained with almost quantitative yield.

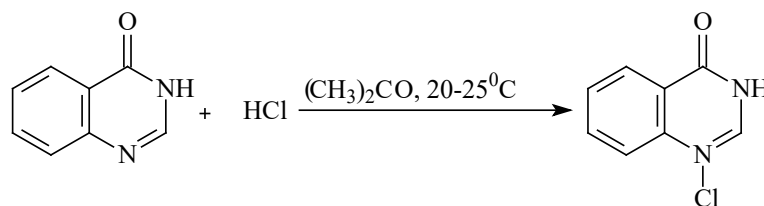

Derivatives of quinazolin-4-oh have been studied for anthelmintic activity against gastric-intestinal fascioles of various concentrations in laboratory conditions. According to the test results, the derivative did not exhibit anthelmintic properties. On the other hand, it has been studied that quinazolin-4-oh hydrochloride has anthelmintic properties. Substances that fight certain anthelmintics were obtained in the form of Medamine, Albendazole, a confirming (reference) agent in the fight against a wide range of spirals. Good results were achieved in cattle, sheep, goats when using quinazolin-4-one hydrochloride. At a dose of 100–150 mg/kg, it exhibits 92% anthelmintic activity against fascioliasis.

In the future, it is possible to create drugs from among substances derived from quinazolin-4-oh and quinazolin-4-tion, which may exhibit high anthelmintic activity. Thus, the recommended quinazolin-4-oh hydrochloride can be used as an effective drug against fascioliasis helminthiasis.

1. A one-stage method for obtaining quinazolin-4-oh has been developed by condensation of anthranilic acid and formamide when heated into Wood alloy. The optimal temperature was established – 130–135 °C, duration 2 h

2. It was shown that quinazolin-4-oh hydrochloride in doses of 100–150 mg/kg eliminates up to 100% of helminthiasis of gastrointestinal fascioles.

References

- Saitkulov, F. E., Tashniyazov, A. A., Mamadrahimov, A. A., & Shakhidoyatov, K. M. (2014). 2, 3-Dimethylquinazolin-4 (3H)-one. *Acta Crystallographica Section E: Structure Reports Online*, – 70(7).– o788-o788.
- Sapaev, B., Saitkulov, F. E., Tashniyazov, A. A., & Normurodov, O. U. (2021). Study of methylation reactions of 2-phenylquinazolin-4-tion with “soft” and “hard” methylation agents and determination of its biological activity. In *E3S Web of Conferences* (Vol. 258, p. 04023). EDP Sciences.
- Sapaev, B., Sapaev, I. B., Saitkulov, F. E., Tashniyazov, A. A., & Nazaraliev, D. (2022, June). Synthesis of 2-methylquinazolin-4-thione with the purpose of alkylation of 3-propyl 2-methylquinazolin-4-thione with alkylating agents. In *AIP Conference Proceedings* (Vol. 2432, No. 1). AIP Publishing.
- Baymuratova, G., Nasimov, K., & Saitkulov, F. (2023). Synthesis of 6-benzylaminopurine and the study of biological active properties of cotton C-6424 plants. In *E3S Web of Conferences* (Vol. 389, p. 03032). EDP Sciences.
- Khatamov, K., Saitkulov, F., Ashurov, J., & Shakhidoyatov, K. (2012). 3, 5, 6-Trimethylthieno [2, 3-d] pyrimidin-4 (3H)-one. *Acta Crystallographica Section E: Structure Reports Online*, 68(9), o2740-o2740.
- Foziljon Saitkulov, Bairamdurdi Sapaev, Khasan Nasimov, Dilorom Kurbanova and Nargiza Tursunova. Structure, aromatic properties and preparation of the quinazolin-4-one molecule. *E3S Web of Conf.*, – 389. (2023).– 03075 p.
- Bairamdurdi Sapaev, Foziljon Saitkulov, Muattar Mamedova, Shahlo Saydaliyeva and Dilafroz Makhmudova. Chromato-mass-spectrometry of the analysis of the sum of the common mushrooms 01006 Published online: 04 September, 2023.
- Сайткулов, Ф. Э., Элмуратов, Б. Ж., & Гиясов, К. (2023). Алкилирования хиразолин-4-она «мягким» и «жестким» алкилирующими АГЕНТАМИ. *Universum: химия и биология*, (1–2 (103)), 53–56.

- Saitkulov, F., Qilichyeva, N., Abdullayev, B., Anvarov, A., & Ergasheva, M. (2022). Titrimetric analysis of calcium cation in «megaton» variety of cabbage. *International Bulletin of Applied Science and Technology*, – 2(10). – P. 134–135.
- Saitkulov, F., Farhodov, O., Olishева, M., Sapparboyeva, S., & Azimova, U. (2022). Chemical feeding method of lemon plant using leaf stomata. *Академические исследования в современной науке*, – 1(17). – P. 274–277.
- Boymuratova, G. O., Saitkulov, F. E., Nasimov, K. M., & Tugalov, M. (2022). To Examine the Processes of Biochemical Action Of 6-Benzylaminopurine with Cobalt-II Nitrate Dihydrate on the “Morus Alba” Variety of Moraceae Plant. *Eurasian Journal of Physics, Chemistry and Mathematics*, – 3. – P. 39–42.
- Murodillayevich, K. M., Shoyimovich, K. G., & Ergashevich, S. F. (2022). Chromato-Mass Methods for Detecting Simple Esters in Chromatography-Mass Spectrometry Method. *international journal of biological engineering and agriculture*, – 1(6). – P. 53–56.
- Сайткулов, Ф. Э. (2022). Гиясов Кучкар, Элмуратов Бурхон Жураевич Метилирование 2-метилхиназолин-4-она «мягкими» и «жесткими» метилирующими агентами. *Universum: химия и биология*, (11–2), – 101 с.
- Saitkulov, F., Begimqulov, I., O'ralova, N., Gulimmatova, R., & Rahmonqulova, D. (2022). Biochemical effects of the coordination compound of cobalt-II nitrate quinazolin-4-one with 3-indolyl acetic acid in the “amber” plants grades PHASEOLUS AUREUS. *Академические исследования в современной науке*, – 1(17). – P. 263–267.
- Saitkulov, F., Elmuradov, B., O'lmasova, K., & Alijonova, A. (2023). preparation of a mixed coordination compound cobalt-ii nitrate hexahydrate with quinazoline-4-one and 3-indolylacetic acid on “amber” plants of the phaseolus aureus variety. *Science and innovation in the education system*, – 2(1). – P. 81–87.
- Bairamdurdi Sapaev, Foziljon Saitkulov, Muattar Mamedova, Shahlo Saydaliyeva and Dilafruz Makhmudova. Chromato-mass-spectrometry of the analysis of the sum of the common mushrooms. *BIO Web Conf.*, – 65. (2023). – 01006 p.

submitted 17.01.2024;

accepted for publication 31.01.2024;

published 18.03.2024

© Saitkulov F. E., Elmuradov B. Z., Sapaev B.

Contact: fsaitkulov@bk.ru



DOI:10.29013/AJT-24-1.2-36-43

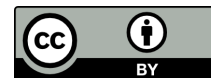

INVESTIGATION OF THE CHEMICAL–MINERALOGICAL COMPOSITION OF BENTONITE OF THE KHAUDAG DEPOSIT AND SYNTHESIS OF WINE FINING AGENTS BASED ON ITS

*Eshkurbonov Furkat Bozorovich*¹, *Rakhimov Alisher Khudaikulovich*²,
*Safarova Ezoixon Ramazon kizi*¹, *Ashurova Asal Abdualim kizi*¹

¹ Termiz Institute of Engineering and technology, Termiz, Uzbekistan

² Denau Institute for Entrepreneurship and Pedagogy, Denau, Uzbekistan

Cite: *Eshkurbonov F.B., Rakhimov A.Kh., Safarova E.R., Ashurova A.A. (2024). Investigation of the Chemical–Mineralogical Composition of Bentonite of the Khaudag Deposit and Synthesis of Wine Fining Agents Based on Its. Austrian Journal of Technical and Natural Sciences 2023, No 11-12. <https://doi.org/10.29013/AJT-24-1.2-36-43>*

Abstract

Fining is about removing unwanted material from wine while still in the cellar. It is part of the clarification and stabilisation process and involves adding a substance to the wine that will flush out certain elements that may cause a wine to look hazy or affect its aroma, colour or bitterness. Fining removes ‘colloids’, which are molecules that include tannins, phenolics and polysaccharides. The fining agent binds to the unwanted particles in the wine, which means they become sizeable enough to be filtered out. The chemical and mineralogical composition of the Khovdak bentonite clay for the production of sorbents was studied. Microscopic studies of samples of bentonite clays were carried out using an MBS-10 optical microscope in transmitted and polarized light with an installed digital camera with a magnification factor of up to 600 s. The study of the phase composition of samples of bentonite clays of the Khaudag deposit was carried out by X-ray analysis.

Keywords: *bentonite clay, bentonite, montmorillonite, adsorbent, sorption, enrichment process, phase composition, wine clarification, scanning electron microscope (SEM), thermal analysis, microdiffraction analysis*

1. Introduction

Fining is understood as clarifying, making wine resistant, correcting its acidity, and accelerating the aging process. For this, wetting agents (gelatine, fish glue, egg protein, bentonite, etc.) are added to the wine, which react with the colloidal substances contained in the wine. Proteins and additives in wine

react with astringents to form insoluble compounds. These compounds settle down in the sediments, and during the sedimentation, the small particles in the wine become briquettes and make the wine clear (N. Sh. Abdullaev, P. N. Ruziyev, O. N. Rakhmatov, 2012).

Fining is not only to clarify the wine, but also improves its taste and aroma, and

increases its resistance to diseases. During wine fining, small particles of wine are adsorbed on the coagulated particles. As a result, under the influence of gravity, it forms bubbles, sinks down and separates from the wine (N.SH. Abdullaev, N.SH. Abdullaev, J.R. Khushvaktov, Kh. Sadullaev, I.U. Khaydarov, 2019).

Bentonite, which is used as an adhesive, is considered an inert substance and does not react chemically with substances contained in wine. It adsorbs small particles contained in the wine, forms coagulated patches, sinks down and separates from the wine (L.A. Ivanova, L.I. Voyno, I.S. Ivanova, 2008).

In the world, bentonites and their varieties play a significant role in the form of a mineral supplement, in the breeding of farm animals and poultry, as well as deodorization of premises. The use of bentonite clays is associated with their chemical composition, which includes many vital micro and macro elements.

Various artificial and natural materials are used as sorbents: ash, coke breeze, peat, silica gels, aluminum gels, active clays, varieties of bentonite, etc. It should be noted that, depending on the nature and content of minerals, their sorption and selective properties of the oils removed from cottonseed related substances. Thus, for example, it is known from the literature that Angren kaolin effectively absorbs gossypol and its derivatives (N.K. Nadirov, 1973), and activated carbon absorbs carcinogenic substances (residues of a hydrocarbon solvent, 3,4-benzopyrene, etc.) (B.S. Ksenofontov, 2011).

In this study, compounds based on bentonite and organic monomers were synthesized (F.B. Eshkurbonov, et al. 2022a-c). Recommendations are given on the use of the synthesized compounds in the food industry.

It should be noted that in order to achieve maximum levels of water purification using sorbents based on bentonite clay, their activation and modification is required. In turn, the organization of the production of adsorbents on an industrial scale requires targeted research and the development of new and highly efficient technologies for the complex processing of bentonite clays based on their chemical and mineralogical composition, structure and sorption properties their further place of application.

In the Jarkurgan district of the Surkhandarya region, there is the Khaudag deposit, where there are reserves of bentonite raw materials in the amount of 1091 thousand tons, which are developed by the MS-MARJON Chamber of Commerce and Industry to meet the needs of farms with their products as agro-ore raw materials and other areas of consumption.

Researchers (F.B. Eshkurbonov, A. Kh. Rakhimov, G. Kh. Toirova, 2022) for the first time modified Khaudag bentonite with polymer compounds and obtained a new composition. Most natural clay adsorbents partially or completely do not adsorb the carcinogenic substance 3,4-benzo[a]pyrene from the extraction oil.

2. Methods and materials

This problem has been proven to be partially overcome with the help of the above synthesized compound. In addition, as a result of the research, the polymer product obtained on the basis of dimethylolurea and orthophosphoric acid (DMU+OPA) was reprocessed with bentonite and a composition was obtained. In order to determine the possible areas of application of this mechanical composite, its studied physical and chemical properties were presented in further studies (F.B. Eshkurbonov, A. Kh. Rakhimov, N.A. Izzatillaev, A.I. Botirov, 2022).

A composition was created on the basis of Khaudag bentonite and a polymer additive, and practical work was carried out on its effectiveness in cleaning vegetable oils (F.B. Eshkurbonov, A. Kh. Rakhimov, Sh.M. Bobokulova, F.R. Abdurakhmonov, 2022). Optimum conditions for obtaining an import-substitute composition for oil refining with the help of synthesized compositions were determined. According to it, it was found that the UFPA-1-B sorbent (based on urea-formaldehyde (UF) and phosphoric acid) has higher sorption properties than the UFAP-1-B (based on UF and ammonium phosphate) composition. In addition, it was determined that the optimal conditions for activation are 4 hours of activation using 15% H_2SO_4 acid. It was found that the use of 2% in oil whitening with the help of the obtained compositions leads to maximum oil purification. The amount of bleaching sorbents

used varies from 0.5 to 5%, depending on the amount of dyes in the oil to be treated and the degree of bleaching required.

When an activated adsorbent is used in the bleaching process, a small amount of isomerization and the formation of glycerides containing sequentially linked fatty acids are observed. This, of course, leads to a decrease in the quality of refined oils and fats and a shortening of their shelf life. The conditions mentioned above and the size of the oil capacity require that the amount of activated earth used for bleaching be reduced as much as possible. At present, activated adsorbents are imported from foreign countries and used for adsorption purification of vegetable oils in various sectors of our oil industry (M. A. Mamajonova, D. S. Salikhanova, E. B. Abduraxmonov, M. A. Ismoilova, (2020). Localization of adsorbents coming from abroad and their use in the food industry remains one of the urgent issues of today.

In this research work, for the first time, studies were conducted on the use of Khaudag bentonite and its composite compound with polymer compounds for wine clarification in the wine industry. Before starting research work, bentonite of Khaudag is acid activated. After that, it is separately modified with polyacrylonitrile (PAN) and DMU.

A comprehensive study of the mineralogical composition of bentonite and its modified forms was carried out by the methods of X-ray, thermogravimetric and electron microscopic analyzes, the use of which makes it possible to explain the influence of changes occurring in the process of modification on their properties.

X-ray diffraction patterns were taken with an XRD-6100 X-ray powder diffractometer (Shimadzu, Japan). CuK α radiation was used (β -filter, Ni, 1.54178 current mode and tube voltage 30 mA, kV) and a constant detector rotation speed of 4 deg/min with a step of 0.02 deg, and the scanning angle varied from 4 to 80°C.

The cell for DTA has a recorder of the temperature difference between the test sample and the standard – aluminum oxide Al₂O₃ and a recorder of the sample temperature. The method of work includes preparing the device for operation, calibration processes,

conducting the main test, processing curves, calculations and interpretation of the results obtained.

Electron microscopic studies were carried out on a scanning electron microscope (SEM) EVO MA10 SEM Cari Zeiss, the use of which makes it possible to view a sample on SEM, determine its quantitative elemental composition, and also obtain color microphotographs.

Thermogravimetric studies were performed using a Paulik-Paulik-Erdey derivatograph system. The heating rate of the samples was 10 °/min, the mass of the test sample was 0.1 g.

The preparation of samples for X-ray phase analysis was carried out in accordance with the guidelines (M. I. Higerovich, A. P. Merkin 1968; V. S. Gorshkov, 1981). The objects under study were preliminarily dried to a constant mass, then ground in an agate mortar until they completely passed through a 006 sieve. unit cell parameters of clay samples according to the formulas below (V. A. Frank-Kamenetsky, (ed) 1983):

$$a = \frac{b}{\sqrt{3}}$$

$$b = 6 * d_{060}$$

$$\sin\beta = \frac{2d_{020}}{a}$$

$$c = \frac{I * d_{001}}{\sin\beta}$$

3. Results and discussion

Experiments have shown that a clay sample from the Khaudag deposit contains mainly sodium montmorillonite (1.4250; 1.3012; 0.4263; 0.2729; 0.2298; 0.1801; 1.4090 nm). The presence of intense lines characteristic of montmorillonite (Fig. 1) proves that in this case it is the main rock-forming mineral. In addition to the lines characteristic of montmorillonite, there are also lines showing the presence of illite (0.9891; 0.3870; 0.3853; 0.3611; 0.3001; 0.1597; 0.1699 nm), kaolinite (0.6993; 0.26001; 0.1499 nm), hydromicas (0.4606; 0.2971; 0.2487; 0.1677; 0.1561 nm), feldspar (0.3853; 0.2298; 0.1884). The sodium form of montmorillonite is proved by the reflex d001 = 1.301 nm.

Figure 1. X-ray diffraction pattern of a Khaudag bentonite sample

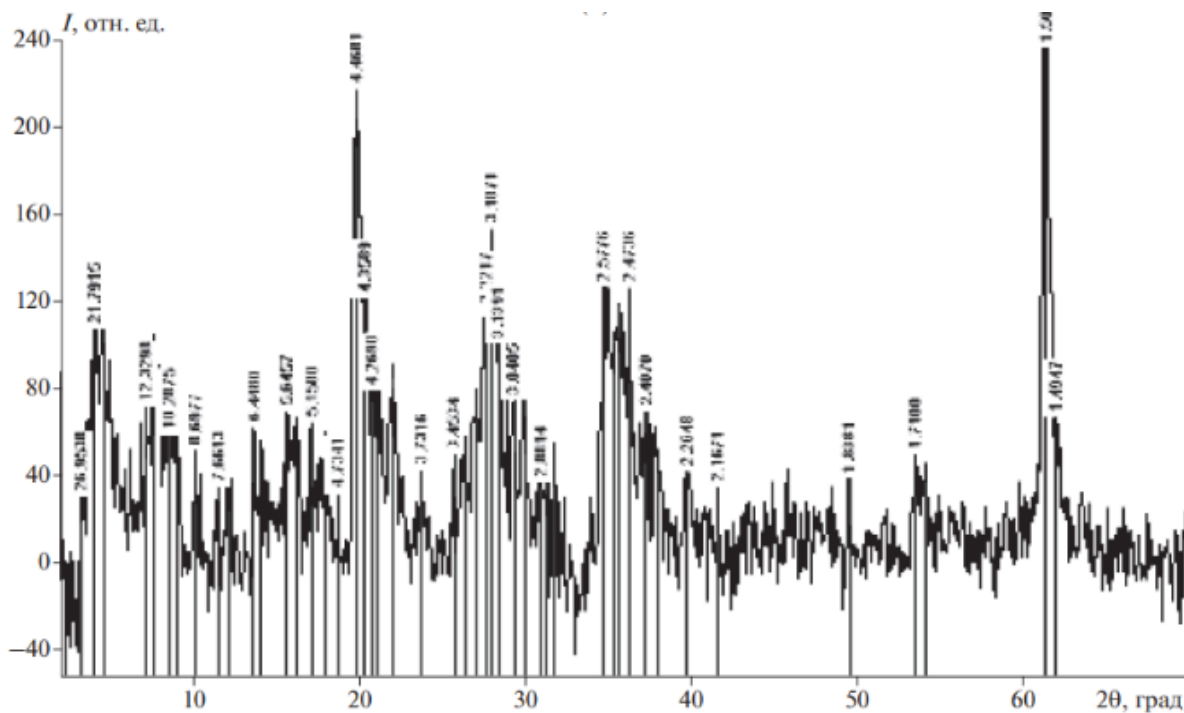
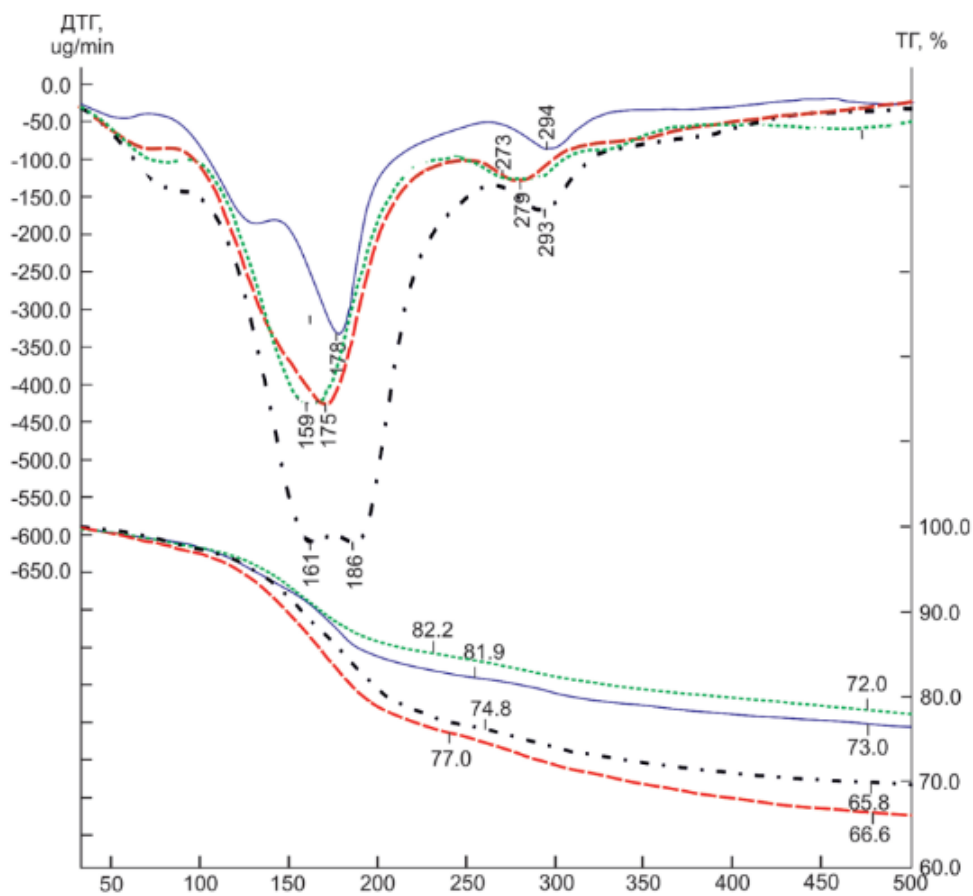

Figure 2. Curve of thermal analysis of Khaudag bentonite sample



Thermal analysis data are consistent with the results of the previous analysis.

On the thermogram of Khaudag bentonite at temperatures of 80–125 °C, an intense

endothermic effect is observed, due to the release of adsorption and interlayer molecular water (Fig 2). The presence of an additional effect at temperatures with a maximum of about 535 °C is caused by the removal of structural water. The third weakest endoeffect at temperatures above 790 °C corresponds to the destruction of the anhydrous modification of montmorillonite and the transformation of the layered aluminosilicate matrix.

Clay samples were studied by Fourier IR spectroscopy on a Nicolet iS50 Fisher Scien-

tific spectrometer, as well as on a UV-NIR spectrophotometer (spectral region 185–3300 nm) UV 3600 Shimadzu. For spectral tests, samples were prepared in powder form and in the form of tablets. The samples were pre-dried at 105 °C in an oven for more than 7 hours. The following chemical elements are fixed on the energy-dispersive spectrum of clay (in descending order): oxygen, silicon, aluminum, iron, potassium, sodium, etc. (Fig 3) Microdiffraction analysis confirms the results obtained by the method of chemical analysis of the composition.

Figure 3. Electron microscopic image of a sample of Khaudag bentonite

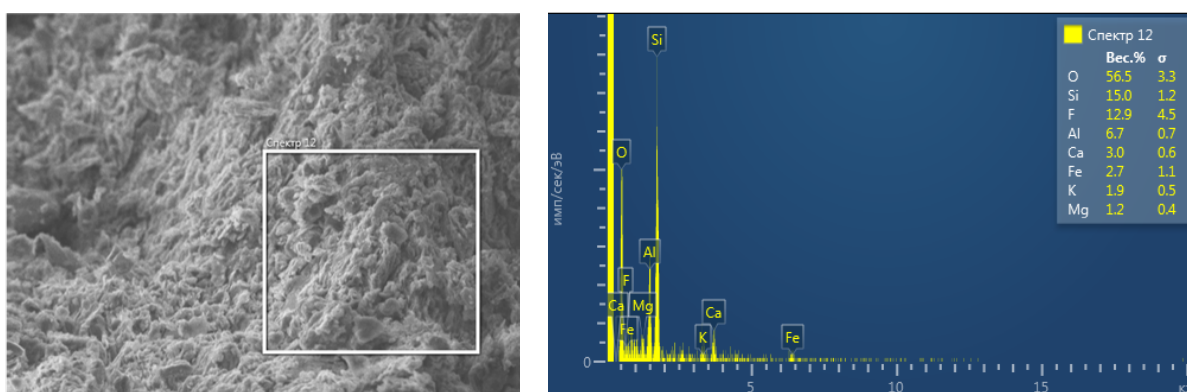
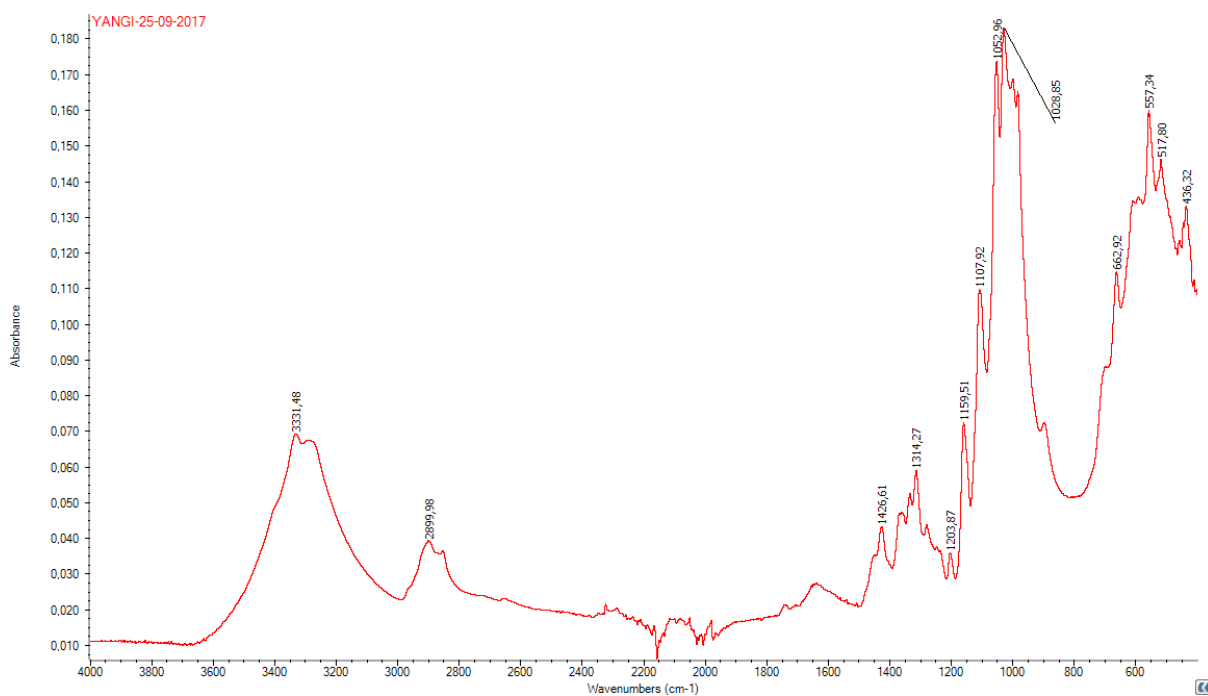

Figure 4. IR spectrum of Khaudag bentonite sample



The interpretation of the above spectrum shows that the main bands shown on them belong to the valence bonds of silicon with oxygen and hydrogen with oxygen (Fig 4).

A well-defined broad band at 1028.85 cm⁻¹ corresponds to the stretching vibrations of the Si-O-Si tetrahedra of the silicon-oxygen framework, and the bands at 517.80 and

436.32 cm^{-1} correspond to the bending vibrations of the Me-O bonds. The band in the interval 662.92 cm^{-1} corresponds to the Si-O-Si vibrations of rings of SiO_4 tetrahedra. Intense bands in the interval 2899.98–3331.48 and 1426.61 cm^{-1} refer to OH valence and deformation vibrations of free and bound water.

Chemical analysis of fine clay fractions was performed according to GOST 21216–2014 (GOST, 1995), according to which the weight

percentages of SiO_2 , TiO_2 , Al_2O_3 , Fe_2O_3 , MgO , MnO , CaO , Na_2O , K_2O , and P_2O_5 were determined. It follows from the data of the chemical analysis that the studied clay is rich in alkali metal ions. In tab. 1 also provides data on the chemical composition of Sherobod bentonite, as a control sample and it shows changes in the chemical composition of bentonites from the Khaudag and Sherobod deposits before and after their enrichment.

Table 1. Chemical composition of clay samples

Name of chemical components	Khaudag bentonite,%		Sherobod bentonite,%	
	before enrichment	after enrichment	before enrichment	after enrichment
SiO_2	61.2	55.3	54.91	38.02
Al_2O_3	16.3	21.2	14.6	30.5
CaO	3.6	3.8	1.6	1.8
Fe_2O_3	2.8	2.3	6.6	6.2
Na_2O	2.4	2.2	1.9	1.7
MgO	3.6	3.8	1.6	1.8
MnO	0.7	0.8	0.4	0.8
K_2O	2.6	2.3	1.65	1.4
P_2O_5	0.3	0.5	0.56	0.68
CO_2	0.12	0.10	0.18	0.25
loss after ignition	6.38	7.7	16	16.85

From tab. Table 1 shows that the content of SiO_2 after enrichment of Khaudag bentonite by elutriation decreased from 61.2 to 55.3%, and of Sherobod bentonite – from 54.91 to 38.02%. And vice versa, the content of Al_2O_3 after enrichment of Khaudag bentonite increased from 16.3 to 21.2%. At the same time, the content of coloring oxides (Fe_2O_3 , TiO_2 , etc.) in both samples decreased by about 2 times. In terms of Al_2O_3 and Fe_2O_3 content, the enriched bentonite of the Sherobod deposit exceeds the enriched Khaudag

bentonite. This favorably affects the quality of the resulting adsorbents and once again confirms the special need for the bentonite enrichment process before their activation.

Above, wine clarification processes were carried out with the help of acid-activated and modified adsorbents. During different periods of time, activated adsorbents were used in the amount of 2% and clarification processes were carried out. The obtained results are presented in Table 2.

Table 2. Effect of activation time on wine clarification process

Name of adsorbent	Activation time, hours	Wine color 35 yellow, in a cuvette 12.5 cm thick		Wine output,%
		Red Unit	Blue Unit	
Khaudag bentonite	Initially	14.2	0.3	–
	2	10.1	0.2	97.5
	4	7.6	0.1	97.2
	6	7.2	0.1	98.1

Name of adsorbent	Activation time, hours	Wine color 35 yellow, in a cuvette 12.5 cm thick		Wine output,%
		Red Unit	Blue Unit	
PAN + Khaudag bentonite	2	7.2	0.1	97.1
	4	6.8	0.09	97.6
	6	6.3	0.07	98.2
DMU + Khaudag bentonite	2	7.0	0.9	96.8
	4	6.4	0.07	97.5
	6	6.1	0.05	98.4
Pakistani Bentonite	2	8.2	0.3	96.8
	4	7.8	0.2	96.5
	6	7.6	0.2	97.2

As can be seen from Table 2, the wine indicators clarified with the help of adsorbents obtained as a result of activation for 4 hours showed the best indicator. Therefore, 4 hours was taken as an optimal condition for further activation processes. For our next work, it is planned to carry on Khaudag bentonite, as this bentonite has been found to clean wine better than Pakistani alkaline bentonite.

The maximum amount of adsorbent used for acid concentration and clarification was used above. At the next stage, research was conducted to find the optimal conditions for acid concentration and adsorbent amount. The obtained results are presented in the following tables 3–4.

Table 3. *Effect of acid concentration on wine clarification process*

Acid concentration,%	Wine color 35 yellow, in a cuvette 12.5 cm thick		Wine output,%
	Red Unit	Red Unit	
10	7.2	0.15	97.7
15	7.1	0.13	98.3
20	7.4	0.12	97.5
25	7.6	0.14	96.2

Table 4. *The influence of the amount of adsorbent on the wine clarification process*

Amount of adsorbent, mg	Wine color 35 yellow, in a cuvette 12.5 cm thick		Wine output,%
	Red Unit	Blue Unit	
1	7.6	0.12	96.9
1.5	7.3	0.14	97.5
2	7.8	0.15	96.3
2.5	8.2	0.14	96.7

From the tables 3 and 4 above, the most optimal condition for the activation of the adsorbent was determined to be the activation using 15% H₂SO₄ acid for 4 hours. In addition, it was determined that the consumption of adsorbent for clarification is 1.5%.

4. Conclusion

In conclusion, the optimal conditions for obtaining an adsorbent that replaces import for wine clarification using local Khaudag bentonite were determined. According to it, it was found that Khaudag bentonite has higher adsorption properties than Pakistani alkaline bentonite. Thus, a comprehensive study of the bentonite of the Khaudag deposit

showed that its main constituent is the mineral montmorillonite. The clay of this deposit differs from other clays of Uzbekistan by a low content of harmful impurity non-clay materials.

In addition, it was determined that the optimal conditions for activation are 4 hours of activation using 15% H_2SO_4 acid. It was determined that the use of 1.5% in wine clarification with the help of adsorbents leads to the maximum purification of wine.

References

- Abdullaev, N.SH., Khushvaktov, J.R., Sadullaev, Kh., Khaydarov, I.U. (2019). Production technology of beer and wine products // Study guide,– Bukhara,– P. 179–187. (in Uzbek)
- Abdullaev, N. Sh., Ruziyev P.N., Rakhmatov O.N. (2012). Production technology of wine products // Textbook,– Tashkent,– P. 103–106. (in Uzbek)
- Eshkurbonov, F.B., Rakhimov, A. Kh., Bobokulova, Sh.M., Abdurakhmonov F.R. (2022). Application of ion-exchange composite materials based on Khaudag bentonite in vegetable oil bleaching // Scientific Bulletin of SamGU, Samarkand.– No. 5 (135).– P. 85–88. (in Russian)
- Eshkurbonov, F.B., Rakhimov, A. Kh., Izzatillaev, N.A., Botirov, A.I. (2022). Electron microscopic study and description of the surface activity of ion-exchange composite materials // Scientific Bulletin of SamGU,– Samarkand.– No. 3 (133).– P. 85–88. (in Russian)
- Eshkurbonov, F.B., Rakhimov, A. Kh., Toirova, G. Kh. (2022). Study of the sorption properties of a polyacrylonitrile composite filled with Khaudag bentonite // Scientific Bulletin of SamGU, Samarkand.– No. 1 (131).– P. 17–20. (in Russian)
- Frank-Kamenetsky, V.A. (ed) (1983) X-ray analysis of most important types of rock-forming minerals (layer and framework silicates). Nedra, Leningrad. (in Russian)
- Gorshkov, V.S. Methods of physical and chemical analysis of binders: textbook. allowance. V.S. Gorshkov, V.V. Timashev, V.G. Savelyev: – M: Higher. school, 1981.– 335 p.
- GOST 21216.0–93. Clay material. Test methods. National standard of the Russian Federation. 01/01/1995.
- Higerovich, M.I. Merkin, A.P. (1968). Physico-chemical and physical methods for the study of building materials.– M.: Higher school,.– 136 p.
- Ivanova, L.A., Voino, L.I., Ivanova, I.S. (2008). Food biotechnology // Book 2. Moscow.
- Ksenofontov, B.S. (2011). Utilization of sewage sludge by composting with peat // Ecology of production.– No. 2.– P. 40–44.
- Mamajonova, M.A., Salikhanova, D.S., Abduraxmonov, E. B., Ismoilova, M.A. (2020). Adsorption Isotherm, Differential Heat, Entropy and Thermokinetics of Benzene Vapor in Pakistan Bentonite // International Journal of Materials and Chemistry,– 10(2).– P. 23–26.
- Nadirov, N.K. (1973), Theoretical foundations of activation and mechanism of action of natural sorbents in the process of clarification of vegetable oils.– M.: Food industry,– P. 205–210.

submitted 20.01.2024;

accepted for publication 05.02.2024;

published 18.03.2024

© Eshkurbonov F. B., Rakhimov A. Kh., Safarova E. R., Ashurova A.A.

Contact: furqat-8484@mail.ru



Section 4. Food processing industry

DOI:10.29013/AJT-24-1.2-44-47



ANALYSIS OF OILS OBTAINED BY THE PRESSING METHOD FROM FRUIT GRAINS

*Akhmedov Azimjon Normuminovich*¹, *Ishankulova Gavxar Norkulovna*², *Umirova Zilola Sherali kizi*³

¹ Department of Food Technology of Products of the Karshi Engineering and Economic Institute, Karshi, Uzbekistan

² Department of Agricultural Product Storage and Preprocessing Technology of the Karshi Engineering and Economic Institute, Karshi, Uzbekistan

³ Tashkent Institute of Chemical Technology, Tashkent, Uzbekistan

Cite: *Akhmedov A.N., Ishankulova G.N., Umirova Z.Sh. (2024). Analysis of Oils Obtained by the Pressing Method From Fruit Grains. Austrian Journal of Technical and Natural Sciences 2023, No 11-12. <https://doi.org/10.29013/AJT-24-1.2-44-47>*

Abstract

In this article, the physico-chemical properties of apricot, peach and bitter almond seeds were studied, based on which research was conducted on the extraction of amygdalin oil. Oils were obtained by extracting the core of the grains, and these were analyzed and their physico-chemical properties were determined. Also, the process of extracting oil from peach, apricot and bitter almond seeds by pressing method was studied, the physico-chemical properties of apricot, peach and bitter almond seeds were studied, and research was conducted on the extraction of amygdalin oil based on them. Apricot, peach and bitter almond oils have been proven to contain more than 88.0% of unsaturated fatty acids, and more than 20% of unsaturated fatty acids are highly unsaturated essential fatty acids – linoleic and linolenic acids.

Keywords: *apricots, peaches, almonds, seeds, oils, saturated and unsaturated fatty acids, fruits and vegetables, acid number, saponification number, density, moisture, oil yield*

Introduction

It is known that horticulture is developed in Uzbekistan, and the amount of fruits and vegetables grown is increasing year by year. 50% of grown grapes, fruits and vegetables are processed in various ways (drying, canning) (Artikov, A.A., Safarov, A.F., Shomuro-

dov, T.R., Gafurov, K.H., 1991). As a result of such treatment, a large amount of waste, grape seeds, fruit seeds are formed. This waste is an important raw material for the oil industry.

Naturally, during the processing of fruits and vegetables, waste with nutrients is generated (Baymetov, K.I., Turdieva, M.K., Naza-

rov, P., 2011). These wastes can be different depending on the type of fruits and vegetables. Such edible waste can include seeds, pulp, pulp, pulp, etc., which are separated from the processing of fruits and vegetables. Consumable waste generated during processing of fruits and vegetables in most cases makes up 40–50% of the mass of processed raw materials (Agricultural Encyclopedia, 1953). Edible fruit and vegetable waste contains carbohydrates, proteins, fats, minerals, vitamins, dyes, and pectin, just like raw materials. Therefore, these wastes are valuable raw materials for extracting active substances from them.

The kernels of fruit seeds are very rich in fats, the amount of fat in them is 45–50 percent. Due to the presence of unsaturated fatty acids in peach, almond, apricot kernel oil, this oil is quickly digested in the body (Ginzburg, A. S., Gromov, M. A., Krasovskaya, G. I., 1980). The amount of essential amino acids in the protein of fruit kernels is 26–30% of the total amount of amino acids. At the same time, fruit pulp protein contains useful substances such as phenylalanine and tyrosine, unique amino acids that participate in the formation of thyroxine and adrenaline hormones in the human body. It is known that as a result of a violation of the exchange of these amino acids in the human body, the metabolism of the whole body is disturbed.

Apricot, almond and peach kernels are rich in minerals, especially sodium and magnesium. Therefore, it is possible to use almond kernel as an additional raw material for the produc-

tion of some products with high nutritional and biological value, enriching their content. Fruit seeds contain 40–50% oil, and due to the presence of unsaturated fatty acids in its composition, this oil is quickly digested in the body (Yadrov, A.A. 1975; Yadrov, A.A., Popok, N.G., Chernobay, I.G. 1999; Shcherbakov, V.G., Lobanov V.G., 2016). Such oils and cotton lead to the use of a small amount of alkali and adsorbent in the refining of oils (Akhmedov, A.N., 2019; Akhmedov, A.N., Abdurakhimov, S.A., 2018; Akhmedov, A.N., 2012).

Materials and methods

The scientific article uses generally accepted and special organoleptic, physico-chemical, microbiological and biochemical analysis methods for determining the properties of raw materials and finished products. Also, the composition and physico-chemical indicators of raw materials, methods of analysis of raw materials used in pressing, statistical processing of the obtained data and methods of error estimation are presented.

Results

The physico-chemical properties of apricot, peach and bitter almond seeds were studied, and based on them, research was conducted on obtaining amygdalin oil. Kernels were separated and oils were obtained by extraction method. The obtained oils were analyzed and their physicochemical properties were determined and are listed in Table 1.

Table 1. *Physico-chemical parameters of oils obtained by extraction method from fruit kernels*

Oil type	Density, g/ml (15 °C)	Refractive index (20 °C)	Acid number, mg KOH/g	Content of moisture and volatile substances, %	Oil output, %
Apricot	0.908	1.472	1.9	0.2	38.8
Peach	0.912	1.470	2.1	0.2	38.5
Bitter almonds	0.912	1.471	2.1	0.3	46.4

Table 1 shows that the physicochemical properties of apricot, peach and bitter almond kernel oils are very close to each other. They can differ from each other only structurally and with fatty acid composition. Processes of oil extraction from peach, apricot

and bitter almond seeds by pressing method have been studied. The obtained results are shown in Table 2.

Table 2. *Physico-chemical parameters of oils obtained by pressing method from fruit kernels*

Nº	Indicator name	Apricot	Peach	Bitter almonds
1.	Refractive index, n _D =20 °C	1.472	1.470	1.471
2.	Density, g/ml, 25 °C	0.908	0.912	0.912
3.	Saponification number, mg KOH/g	191	190	192
4.	Iodine number, g J ₂ /100 g	101	100	100
5.	Peroxide number, mole of active oxygen	2.82	3.0	3.85
6.	Acid number, mg KOH/g	1.7	1.3	1.1
7.	Content of moisture and volatile substances, %	0.4	0.5	0.4
8.	Oil yield, % relative to kernel	29.6	29.3	27.8

It can be seen from Table 2 that the acid number of the oils obtained by the pressing method is lower compared to the oils obtained by the extraction method. Apricot oil has a higher iodine value than peach and bitter almond oils, indicating that it contains

more saturated fatty acids. However, a higher refractive index indicates that it may contain more unsaturated fatty acids. Therefore, the fatty acid composition of the obtained oils was analyzed (Table 3).

Table 3. *Fatty acid composition of oils obtained from fruit seeds*

The name of the acid	Oil type, %		
	Apricot	Peach	Bitter almonds
Palmitin	5.56	4.93	6.35
Stearin	1.94	2.18	2.05
Olein	63.76	61.46	68.6
Linol	26.15	26.44	20.11
Linolene	1.01	0.10	0.38
Arachnid	0.50	0.46	0.19
Other	1.08	4.43	2.32
Total	100	100	100

From the data in Table 3, it can be seen that apricot, peach and bitter almond oils contain more than 88.0% unsaturated fatty acids. More than 20% of unsaturated fatty acids are highly unsaturated essential fatty acids – linoleic and linolenic acids.

Discussion and Conclusion

The kernels of fruit seeds are very rich in fats, the amount of fat in them is 45–50 percent. Due to the presence of unsaturated fatty acids in peach, almond, apricot kernel oil, this oil is quickly digested in the body.

The amount of essential amino acids in the protein of fruit kernels is 26–30% of the total amount of amino acids. The physico-chemical properties of apricot, peach and bitter almond seeds were studied, and based on them, research was conducted on obtaining amygdalin oil. As a result, it was found that the physico-chemical properties of apricot, peach and bitter almond kernel oils are very close to each other, they can differ only structurally and fatty acid content.

Processes of oil extraction from peach, apricot and bitter almond kernels were stud-

ied and showed that the acid number of the oils obtained by the pressing method was lower than that of the oils obtained by the extraction method. It can be concluded from the research that apricot, peach and bitter al-

mond oils contain more than 88.0% of unsaturated fatty acids, and more than 20% of unsaturated fatty acids are highly unsaturated essential fatty acids – linoleic and linolenic acids.

References

- Artikov, A. A., Safarov, A. F., Shomurodov, T. R., Gafurov, K. H. Study of the temperature field in the kernel of oil-containing stone fruit crops. News of universities. Food technology, 1991.– No. 1–3.– P. 174–175.
- Baymetov, K. I., Turdieva, M. K., Nazarov, P. Peculiarities of cultivation of local varieties of apricot in Uzbekistan.– Tashkent, 2011.
- Agricultural Encyclopedia. T. 3 (L - P) / Ed. board: P. P. Lobanov (chief editor) [and others]. Third edition, revised – M., State Publishing House of Agricultural Literature, 1953.– 613 p.
- Ginzburg, A. S., Gromov, M. A., Krasovskaya, G. I. Thermophysical characteristics of food products.– M.: Food industry, 1980.– 288 p.
- Yadrov, A. A. On the relationship of biological processes in the annual development cycle of almond varieties and forms // Bulletin. Nikit. garden botanist. 1975.– Issue. 2 (27).– P. 20–23.
- Yadrov, A. A., Popok, N. G., Chernobay, I. G. Selection of almonds // Intensification of selection of fruit crops.– Yalta, 1999.– P. 151–156.
- Shcherbakov, V. G., Lobanov V. G. Biochemistry and commodity science of oilseed raw materials: Textbook.– 7th ed., revised.– St. Petersburg: Lan Publishing House, 2016.– 392 p.
- Akhmedov, A. N. Investigation of indicators of cottonseed oil obtained by pre-pressing from low-grade cotton seeds // Universum: Technical Science. – Issue: 4(61). April, 2019.– Moscow, 2019,– P. 23–26.
- Akhmedov, A. N., Abdurakhimov, S. A. The study of the grinding process of rushanka from the nuclei of cotton seeds of different varieties. Journal chemistry and chemical engineering. 2018.– № 3.– P. 11–16.
- Akhmedov, A. N. Improving the technology of complex refining of oils obtained from low-grade cotton seeds: Abstract of thesis. diss. ...cand. tech. Sci.– Tashkent, 2012.– 25 p.

submitted 12.02.2024;

accepted for publication 28.02.2024;

published 18.03.2024

© Akhmedov A. N., Ishankulova G. N., Umirova Z. Sh.

Contact: a.ahmedov80@mail.ru



DOI:10.29013/AJT-24-1.2-48-52



RESULTS OF EXTRA HIGH FREQUENCY RADIATION TREATMENT OF COTTON SEED

*Akhmedov Azimjon Normuminovich*¹,
*Kurbonova Oftoboyim Khusniddinova*², *Abdullaev Asadulla Shokir ugli*²,
*Kurbanov Mukhammadali Akhmad ugli*²

¹ Department of Food Technology of Products of the Karshi
Engineering and Economic Institute, Uzbekistan

² Department of Agricultural Product Storage and Preprocessing Technology
of the Karshi Engineering and Economic Institute, Uzbekistan

Cite: *Akhmedov A.N., Kurbonova O.Kh., Abdullaev A.S., Kurbanov M.A. ugli. (2024). Results of Extra High Frequency Radiation Treatment of Cotton Seed. Austrian Journal of Technical and Natural Sciences 2023, No 11-12. <https://doi.org/10.29013/AJT-24-1.2-48-52>*

Abstract

In a scientific article, it was determined that the free gossypol in the fry was significantly less changed when the cotton wool was treated with radiation power in the range of 100 to 300 W. In the control experiments (with industrial method), the material was treated with steam, the moisture content of the material was brought up to 13–15%, and the temperature was brought up to 60–65 °C, after that, the temperature of the roast was brought up to 100–105 °C during 60 minutes. When the oil was treated with 100 W high-frequency radiation, the color of the oil was observed to change after only 5 minutes, and it was found that the number of red units increased to 45 and the number of blue units increased to 2 by the end of the treatment after 30 minutes. Also, it has been proven that the peroxide value of oil obtained from cotton pulp treated with 300–600 W ultra-high frequency radiation with a frequency of 2450 MHz and a power of 300–600 W within 5–30 minutes is changed from 10 to 17 mmol/kg.

Keywords: *cotton seed, extra high frequency radiation, peroxide value of oil, oxidation of fatty acids*

Introduction

Oil production as an industry was established at the beginning of the last century. It is known from the sources that oil separators of the United States of America were initially attracted to our region (Kopeikovskiy, V.M., Danilchuk, S.I., Garbuzova, T.I., Mosyan, 1982; Gavrilenko, I.V., 1939). However, this

equipment did not allow to completely separate the oil contained in the raw material, and the amount of 4–5% of the seed mass remained in the raw material. Cotton lint is a multi-component material containing oil and mainly consists of petal-like pith and boll. According to the used technology, up to 5 percent of returnable goods, that is, fuza in the fuza tank and

sludge in the filter press, are included in the solution (Kopeikovsky, V.M., Danilchuk, S.I., Garbuzova, T.I., Mosyan, 1982).

The changes of gossypol during the industrial processing of cottonseed are divided into two types: changes of gossypol under the influence of heat and oxygen in the air; change as a result of interaction with substances included in the seed (Markman, A.L., Rzhekhin, V.P., 1965). The interaction reaction of gossypol with phosphatides in the presence of water has a definite temperature limit of 106–110 °C, outside of which the reaction rate increases sharply. It is known that the apparent speed of the reaction of gossypol in the oil environment starts at a temperature of 60 °C and its maximum speed is in the range of 80–120 °C (Markman, A.L., Rzhekhin, V.P., 1965). Analysis shows that the intense dark color of raw cottonseed oil is not given by gossypol itself, but by its transformation products and combinations with other substances contained in the seed. Gossypol, which does not contain free aldehyde groups and acidic hydroxyls, has a high ability to stain partial oxidation products, anhydration products, phosphatides, amino acids and products of interaction with diene fatty acids (Markman, A.L., Rzhekhin, V.P., 1965).

Ilyasov A.T. and his staff proposed to neutralize the gossypol in the solution with the help of urea (Ilyasov, A.T. 1996). Two amino groups of urea actively interact with aldehyde groups of native gossypol, eliminating similar chemical changes of gossypol with substances of the gel part of the solution. At the same time, conditions can be created to neutralize free gossypol and preserve proteins, free amino acids and phosphatides in their native state.

The authors (Ilyasov, A.T., Vahabova, D.Z., Urakov, R.M., 1993) purified cottonseed oil with a concentration of 250 g/l of alkali and 4 and 7 kg/t of caustic soda. In control studies, refined oil of the first and second grade standard in terms of color was obtained from forpress and extraction oils, respectively, with a caustic consumption of 7 kg/t, with a yield of 89.7–91.5 and 88.8–89.6%.

Rzhekhin V.P. and his staff studied the interaction of gossypol with protein substances, free amino acids, anthranilic acid, phosphatides and other reagents (Rzhekhin, V.P.

and Preobrazhenskaya, I.S., 1961). It was found that free gossypol practically does not interact with the above-mentioned reagents and forms complex complexes, which are not completely removed from the oil even in the “hard” regimes of alkaline cleaning.

Therefore, the analysis of literary sources on the considered problem shows that the moisture-heat treatment process of cotton pulp occupies an important place in the technology of extracting plant, especially cotton oil. Switching this process to a “soft” mode will undoubtedly help to increase the technical and economic efficiency of the subsequent processing of oil and slag.

Materials and methods

In the scientific article, the results obtained from the use of cotton seed pulp processing, physico-chemical analysis of oil refining and its processing products, modern high-performance liquid chromatography, gas chromatography and other modern methods of physico-chemical analysis and the data obtained in laboratory and experimental-production conditions are reliable. The limit value of the interval is based on the correspondence to the theoretical results.

Press oil analysis was performed based on the following methods:

- cotton oil color is determined by Lovibond cotton color meter according to UzDSt 1199:2009 (O'zDSt 1199: 2009);

- the amount of free gossypol was determined by the method of high-performance liquid chromatography. An Agilent Technologies (USA) 1200 series liquid chromatograph was used, with a DAD detector. Column Ultropac Column Lihroprep RP18, 5 μ m, 2.6x100mm. Gossypol was added to 1.0–1.5 μ m of acetonitrile and eluted from the column at room temperature in isocratic mode using a solution of 0.1% acetonitrile, phosphoric acid and water (80:20). Detection was carried out with 254 nm (Abou-Donia, S.A., Laches, J.M., Abou-Donia, M.B. 1981).

Also, in some studies, determination of the mass fraction of free gossypol in oil was carried out according to the methodology certified by the State Standard certificate No. 188 (TSh 88.06–27: 2011).

This method for measuring the mass fraction of free gossypol in oil applies to

unrefined cottonseed oil and to high-sipol crude cottonseed oil in the range of 0.50% to 1.5%, using the aniline method.

This method is based on the interaction reaction of gossypol with aniline and the formation of dianilinegossypol, which is insoluble in oil and some organic solvents.

– the acid number of oils was calculated according to UzDSt 1203, and a 1 percent alcohol solution of phenolphthalein was taken as an indicator (O'zDSt 1203: 2009). This method is based on the titration of an oil sample with an alkaline solution in the presence of a phenolphthalein indicator.

A neutralized solution of alcohol and diethyl ether was used as an oil solvent.

– mass fraction of moisture volatile substances calculated according to UzDSt 1193:2009 (O'zDSt 1193: 2009);

– the degree of oxidation of oils is measured according to UzDSt 1200:2009, depending on the peroxide value calculated by the iodometric method (N.S. Arutyunyan, E.A. Arisheva, L.I. Yanova, M.A. Kamyschan, 1983; O'zDSt 1200:2009).

Results

Currently, many scientists are conducting research on eliminating the above defects, reducing the cost of the processes, etc. Ultra-high frequency radiation is considered to be a new method of moisture-heat treatment of cotton wool, which has the ability to reduce the above defects. Normal microwave devices, based on their physical parameters, work only at 2450 MHz, their regulated parameters are radiation power (w, W) and processing time (t, min.) (Yulchiev, A. B., Abdurahimov, S. A., Serkaev, K. P. 2009).

Laboratory studies show that the free gossypol in the roast changes much less when the roast is treated with radiation pow-

er in the range of 100 to 300 W. This can be explained by the shorter processing time and lower temperature of the processed material, unlike the industrial method.

During moisture-heat treatment and frying, along with the changes mentioned above, the color of the oil also changes. Changes in the color of cottonseed oil depend on many factors, such as changes in the amount of dyes, gossypol, proteins, phospholipids, glucose, etc. (Yulchiev, A. B., Abdurahimov, S. A. Serkaev, K. P., 2011).

It is known that the degree of coloring of the oil depends on the method and duration of preparation of the oil for pressing. In contrast to the industrial method of roasting cotton, ultra-high-frequency processing is carried out with a rapid acceleration of the pressure of liquids in the processed material. To determine the change in the color of oil in ultra-high-frequency radiation, cotton wool was subjected to normal (industrial) method (control) and in laboratory equipment under ultra-high frequency (experience) processed.

In the control experiments (with industrial method), the material was treated with steam, the moisture content of the material was brought up to 13–15%, and the temperature was brought up to 60–65°C, after that, the temperature of the roast was brought up to 100–105°C during 60 minutes.

In the laboratory experiments, as in the control experiment, the material was first treated with steam, the moisture content of the material was raised to 13–15%, and the temperature was raised to 60–65°C, and then it was treated with high-frequency radiation of various powers for 30 minutes. In both experiments, samples were extracted after every 5 minutes to press the oil and measure its color change. The results of the experiments are shown in table 1.

Table 1. Variation of color of oil in frying depending on the method and duration of processing

Processing method	Color of frying oil, Lovibond red(blue) units in 1 cm layer of the cuvette. Processing time, minutes							
	5	10	15	20	25	30	40	60
Color of frying oil, red(blue) units in 1 cm layer of cuvette according to Lovibond.								
Industrial style	20(3)	22(3)	26(3)	30(3)	35(2)	40(2)	49(1)	54(1)
Power of high-frequency radiation during processing:								
W=100 w	21(3)	26(3)	30(2)	36(2)	40(2)	45(2)	–	–

Processing method	Color of frying oil, Lovibond red(blue) units in 1 cm layer of the cuvette. Processing time, minutes							
	5	10	15	20	25	30	40	60
W=300 w	30(2)	34(2)	38(2)	43(2)	46(2)	48(2)	–	–
W=600 w	34(1)	42(1)	56(1)	68(1)	–	–	–	–

Discussion and Conclusion

It can be seen from Table 1 that when the material is treated in an industrial way, the color of the oil does not change much in the first 10–15 minutes, because this time of treatment is spent on raising the temperature. In the next 20–25 minutes, changes in gossypol, dyes, etc. occur, as a result, the color of the oil deteriorates sharply and the number of red cells increases from 30 to 54. When Yan-chilma is treated with high-frequency radiation with a power of 100 W, the color of the oil begins to change after only 5 minutes, and after 30 minutes, until the end of the treatment, the number of red units increases to 45 and the number of blue units to 2.

The same changes are observed when the tissue is treated with 600 W high-frequency radiation. Only by increasing the processing power will the duration of changes be reduced. For example, when the material is treated with high-frequency radiation with a power of up to 600 W, the intense color change lasts up to 20 minutes, and then the material is excessively roasted and its color becomes invisible.

It is known that changes in blue units in cottonseed oil often mean changes in chlorophyll and its derivatives. It can be seen from the data in table 3.3 that in the industrial method of processing, blue units change after 25–30 minutes and at the end of processing, they decrease to 1/3 of the initial amount.

We have studied the changes in the peroxide number of oil extracted from cotton pulp treated for 5–30 minutes with 2450 MHz, 300–600 W ultra-high frequency radiation.

The analysis of the peroxide number of the oil was carried out according to the manual O'zDSt 1200:2009 "Calculation of the peroxide number of vegetable oils" (O'zDSt 1200:2009).

It was determined that the peroxide value of the press oil changes from 10 to 17 mmol/kg during the ultra-high frequency irradiation of the cotton pulp in the above regimes. At the same time, the peroxide value of the oil increases with the increase of the high frequency radiation power (from 300 to 600 W) and the microwave treatment time (from 5 to 30 minutes). At the same time, the peroxide value of the oil increases with the increase in strength (Yulch-iev, A. B., 2015).

A comparison of the results of the analysis of the oils obtained as a result of the traditional methods and ultra-high frequency treatment of cotton ginning shows that microwave radiation helps to reduce the oxidation of fatty acids in triacylglycerides.

Using ultra-high frequency heating instead of traditional convective roasting of cottonseed reduces the peroxide value of the oil, and this leads to an increase in the output of purified edible oil and a decrease in the costs of its processing.

References

- Kopeikovskiy, V. M., Danilchuk, S. I., Garbuzova, T. I., Mosyan, A. K. Plant production technology. – M.: Light and food industry. 1982. – 416 p.
- Gavrilenko I. V. Automatic oven Bukeya // Masloboyno-girovoedelo. – 1939. – No. 2. – P. 36–37.
- Markman, A. L., Rzhikhin, V. P. Gossypol and its derivatives. – M.: Pishchevaya promyshlennost, 1965. – 244 p.
- Ilyasov, A. T. Technological improvement of cotton seed processing and oil refining. Diss. no soisk. uch. step. doctor of technical sciences. – Tashkent. 1996. – 350 p.
- Ilyasov, A. T., Vahabova, D. Z., Urakov, R. M. Forrafinatsiya hlopkovo masla carbamidom. Doctoral thesis. Scientific theory. and tech. conf. prof. teacher, aspir., nauch. rab. student Tashkhti, – Tashkent, 1993. – 58 p.

- Rzhekhin, V. P. and Preobrazhenskaya, I. S. Interaction of phosphatides with gossypol in gasoline and oil environments // *Maslozhirovaya promyshlennost*. 1961.– No. 2.– P. 9.
- O'zDSt 1199: 2009. Plant issues. The method of determining color.– Tashkent. Gosstandart. 2009.– 11 p.
- Abou-Donia, S. A., Laches, J. M., Abou-Donia, M. B. High-efficiency liquid – chromatographic analysis of gossypol. (High performance liquid chromatography analysis of gossypolum). *J. Chromatography*.– 206 (3). 1981.– P. 606–10.
- TSh 88.06–27: 2011. Cotton oil, unrefined, high-quality cotton. Appendix “B”. The method of determining the amount of free gossypol.– Tashkent. Gosstandart. 2011.– 9 p.
- O'zDSt 1203: 2009. Plant issues. The method of determining the acid number.– Tashkent. Gosstandart. 2009.– 10 p.
- O'zDSt 1193: 2009. Plant issues. The method of determining moisture and volatile substances.– Tashkent. Gosstandart. 2009.– 11 p.
- Laboratory workshop on technological processing of Zhirov / N. S. Arutyunyan, E. A. Arisheva, L. I. Yanova, M. A. Kamyshan – M.: Light and food industry, 1983.– 152 p.
- O'zDSt 1200:2009. Plant issues. The method of determining the number of peroxides.– Tashkent. Gosstandart. 2009.– 9 p.
- Yulchiev, A. B., Abdurahimov, S. A., Serkaev, K. P. The effect of microwave cotton processing on radiation and structure // *Chemistry and chemical technology*. 2009.– No. 4.– P. 72–74.
- Yulchiev, A. B., Abdurahimov, S. A. Serkaev, K. P. Change in porosity and pore size of cotton balls after microwave irradiation. // *Chemistry and chemical technology*.– 2011.– No. 2. P. 76–78.
- Yulchiev, A. B. Influence of microwave oven – processing of cotton balls on indicators of pressed oil and jam // *Oil and fat industry* 2015.– No. 3.– P. 13–17.

submitted 14.02.2024;

accepted for publication 01.03.2024;

published 18.03.2024

© Akhmedov A. N., Kurbonova O. Kh., Abdullaev A. S., Kurbanov M. A. ugli.

Contact: a.ahmedov80@mail.ru



Section 5. Light industry

DOI:10.29013/AJT-24-1.2-53-57



ECONOMIC TRANSFORMATIONS IN THE INDUSTRY OF THE REPUBLIC OF KARAKALPAKSTAN IN THE SECOND HALF OF THE 90S OF THE XX CENTURY

*Azamat Ktaybekov*¹

¹ Nukus State Pedagogical Institute, Uzbekistan

Cite: Ktaybekov A. (2024). *Economic Transformations in the Industry of the Republic of Karakalpakstan in the Second Half of The 90s of the XX Century. Austrian Journal of Technical and Natural Sciences 2023, No 11-12.* <https://doi.org/10.29013/AJT-24-1.2-53-57>

Abstract

This article highlights the process of economic transformation that took place in the industry of the Republic of Karakalpakstan in the second half of the 1990s. The author analyzes the main factors that influenced the industrial development of the region in the period of transition to a market economy after the collapse of the Soviet Union. The article considers changes in the legal and economic spheres, the role of the state and the private sector, as well as the influence of international factors on the development of industry in Karakalpakstan. The article also describes the challenges and problems faced by industrial enterprises in the region and offers an analysis of the prospects for the future development of the economy and industry of the Republic of Karakalpakstan.

Keywords: *light industry, innovations, market relations, raw materials, enterprises*

Introduction

During the years of independence Uzbekistan and together with it Karakalpakstan through large-scale reforms have achieved significant progress in the field of economic stabilization and reforms on transition to a market economy. Overcoming the nature of the economy based on the export of raw materials and planned principles inherited from the Soviet Union leads to positive results in the development of the national economy.

In solving these problems, the creation of a highly efficient industry is a priority. The experience of advanced countries convincingly

proves that it is impossible to break through, to take a worthy place in the world economy without the development of industry at a high level. Therefore, at present, the understanding that the industrial sector of the economy is a key factor in the national revival, successful advancement of the republic on the path of historical progress is becoming more and more established in the public consciousness.

Main part

Gaining independence has objectively opened wide prospects for economic and social progress, cultural and spiritual renewal

for the people of Uzbekistan. Realistically assessing the situation in the mid-90s of the XX century in the republic, it can be stated that Karakalpakstan has entered a qualitatively new stage of its state-political and economic construction. The first visible steps have been taken to create a state based on the rule of law, and reforms related to the transition to market relations have been implemented. Structural changes have been made in the national economy to meet the requirements of market relations. The Government has taken a number of important decisions to ensure that the laws that form the legal basis for the development of market relations are fully operational. As a result, a multi-structured economy based on the equitable existence of various forms of ownership has begun to take shape.

As a result, thanks to the economic reforms carried out in the country in the second half of the 1990s, the share of the non-state industrial sector of the economy tended to grow. So if in 1996 out of 144 industrial enterprises and associations of the Republic of Karakalpakstan 113 worked under different forms of ownership, including private – 20, collective – 50, state-joint-stock – 41 and 2 joint ventures and their share accounted for 86.7 percent of the industrial output produced during the year, then by the results of 2000 it was significantly transformed. It is enough to note that at that time, at the end of the year, the share of the non-state industrial sector of Karakalpakstan's economy in the total volume of commodity production amounted to 94.5 percent, while the state sector accounted for 5.5 percent.

According to statistical data, in 1997 in machine building and metalworking industry low production rates were shown by Electroapparat JSC 77.6%, Kabel JSC 10.0%, Skid AKO 64.3%, AR3–16–41.7%, Nukus ORM 3 87.4%. The reason for this was the shortage of raw materials, namely: metal and plastic (for cable industry). In the light industry all spinning and weaving factories allowed low rates of production by 64.1%, JSC "Aryular" by 50.9%, Khojelinskoe UPP Society of the Blind by 86.6%, Nukus UPP Society of the Blind by 53.4%, JSC "Oner" Muinai district by 76.0%, PF "Zhanar" by 78.0% (Bektemirov, K., 1996).

In 1998, there was a decrease in production facilities compared to 1997 only in the printing

industry by 4.9%, mainly due to the lack of raw materials at the Nukus polygraph plant.

The biggest decrease of production volumes for 1999 is observed in woodworking (it is KK Mebel OJSC by 53,4%) and glass container production (Glass plant and PKP VAN by 40,3%) in comparison with 1998. The main reasons were lack of raw materials, accounts receivable, and difficult financial condition.

In 1999, the volume of production in the light industry decreased by 3%, mainly the largest decrease was made by joint-stock companies of cotton industry: Turtkul OJSC (73.6%), Mangitskaya PTF OJSC (87.3%), Elteks JSC (86.2%); knitting industry – Katek-s JSC (50.0%); garment industry – Kyryk-kyz JSC (29.9%), Nafosat JSC (51.0%), The main reason was the lack of raw materials (cotton fiber) and materials. They needed 561 tons of cotton yarn, 1522 thousand m² of ready-made fabrics, 926 thousand pieces of knitwear, 712 thousand pieces of medical bandages.

Thus, the above analysis of the decline of some industries in the second half of the 1990s shows that there were objective reasons for it. At the same time, it is impossible to reduce the inefficient work of enterprises only to the existing circumstances associated with the difficulties of the transition period to a market economy. The research materials convince us that inertia and carelessness of some managers, who have not yet overcome their dependent moods, also contributed to the emergence of these negative trends. Failure of most enterprises to adapt to market conditions, excessive reliance of their managers on state support led to undesirable consequences.

During the years of independence, the economic policy in Karakalpakstan was fundamentally changed. In 1993 at the XIII session of the Supreme Council of the Republic of Karakalpakstan was adopted the concept ("Concept of the main directions of development... 1993–2000), which became the fundamental program of the republic to overcome the one-sided raw material orientation of the economy and to ensure the output of finished products on the basis of the organization of advanced processing of available mineral raw materials and agricultural raw materials.

Commissioning of Nukus and Kungrad bread mills allowed to put an end to import of flour from outside the republic. Thus, it

was possible to provide the population with this important product of own production. A cable plant in Nukus city with a capacity of 20 thousand kilometers of cable products and a glass container plant in Khojeli district were put into operation. In a short period of time, or rather 1992–1994, two large textile enterprises were built in the city of Nukus and Bustan, which allowed in 1995 to increase the volume of industrial production by 18–20 percent and fill the domestic market with light industry goods, to increase the volume of exported products. Thus, certain prerequisites for the development of import of substitute products in the republic have already started to be created.

At the same time, however, it is necessary to admit that the limited material and financial resources did not allow to fully implement in the first half of the 1990s all the measures outlined in the above program.

In the context of realization of the set tasks, certain structural changes took place in Karakalpakstan in the years under consideration. The research materials show that they mainly affected such branches as fuel and food industry

Thus, in 1996 there were positive changes in the structure of industry. A new branch – fuel industry – appeared in the economy of the republic. The Kungrad gas field enterprise “Urga” started production of gas condensate and natural gas. In the following years the development of the gas field “Urga” in Kungrad district was underway, where, for example, in 2000 4 wells were put into operation (Bektemirov, K., 2006).

The most noticeable structural shifts were observed in the food industry of the RK, especially in the association of joint stock companies “Karakalpak Hleboproduct” which is the only enterprise of the republic that processes grain, supplies flour, polished rice, bakery products, pasta, mixed fodder for the needs of livestock and poultry farming. In the years under consideration, with the purpose of supplying the population with quality products in ever-increasing volume and assortment, a number of enterprises of associations were re-equipped with the latest and imported equipment, new capacities of workshops for production of various food products were put into operation. Thus,

in 1996 in Turtkul, Khojeyli, Chimbay and Beruni joint stock companies were put into operation workshops for production of pasta, confectionery production, which allowed the enterprises of associations to produce 15 kinds of bakery products. In addition, in 1997 the reconstruction of pasta shops in Karauziak and Ellikkala districts with the capacity of 0.3 and 0.6 tons of products per day was completed (Bektemirov, K., 1996). Also in 1998 two new enterprises were put into operation – joint stock companies of open type “Takhtakupirden” and “Turtkulden”. They produced 4635 tons of flour for 144.7 million soums. As a result, the volume indicators of industrial production in the republic in 1998 increased by 0.6 percent. And in 2000 AAP “Karakalpak Hleboproduct” put into operation a seed cleaning shop and a line for production of vitamin herbal flour in Nukus city.

Gaining state independence in 1991 gave Karakalpakstan the opportunity to enter the international arena for the first time independently and establish direct contacts with various states of the world. During 1991–2000, much was done to develop foreign economic activity, which became one of the main directions in the implementation of economic reforms in the republic. The foreign economic policy of “open doors” was formed, which meant the development of relations with all countries of the world while respecting the principle of equality and mutually beneficial cooperation. Finally, a special state body dealing with the implementation of foreign economic policy, the Ministry of Foreign Economic Relations of the Republic of Karakalpakstan, was established (Decree of Jokargy Kenes ... 7.07.92 № 125; Decree of the Council ... 14.09.92 year № 221/9).

The mastering of new advanced production technologies also took place in other industries of the region. In particular, in 1996 in the textile complex of JSC “Katex” a new production was mastered. The textile workers started production of medical gauze on a technological line purchased in Italy. The capacity of the equipment made it possible to produce 6.5 million linear meters of materials and 11 million packs of bandages annually.

In Nukus polygraph plant in 1996–1997 computer equipment for printed publications of “Berthold Stempel” company (Austria)

was installed at a total cost of 1 million 800 thousand D.M., as well as equipment of German company “Heidelberg” was installed. As a result, the quality of newspaper, magazine and book products was improved, and the volume and types of other products were increased. Installation and adjustment of the equipment capable to produce the highest quality products corresponding to the world standards at Nukus polygraph plant was carried out by representatives of the Vienna branch Vladimir Stolbov, Sergey Kalachev, Nikolay Shaposhnikov and their assistants.

In the years under study, the Republic of Karakalpakstan also carried out work to attract foreign investment in the establishment of joint ventures on the territory of the republic. As a result, if in 1996 there were only 4 joint ventures with foreign investments in the industrial sphere of the regional economy, by 2000 their total number reached 14, of which 8 were operating. Joint ventures were established with the participation of investors from Malta, Ireland, USA, Luxembourg, Russia, France, Latvia and Turkey.

The materials of the study show that in the period under review the most effective of the enterprises with foreign capital were the Karakalpak Maltese JV “Karm” for the production of hosiery with a capacity of 3.5 million socks per year, the Karakalpak Irish JV “CACDK” for the production of construction and facing materials with a capacity of 4518 m² of facing tiles per year and the American DP “Plattas”, which created in the city of Nukus mini-plant for the production of vegetable oil with a capacity of 120 thousand liters per year, equipped with a mini-factory for the production of vegetable oil. liters per year, equipped with Bulgarian equipment at a cost of 431 thousand 467 U.S. dollars (“Karakalpakstan tariykhy” (1991–2015-zhyllar).

Thus, the results of the produced activity of JVs allow us to consider them as a necessary condition for achieving the goals of structural reorganization of the national economy. As foreign economic relations of

the Republic of Karakalpakstan with foreign business partners allowed the republic to achieve cardinal shifts in the rational use of agricultural and mineral resources in a short period of time.

At the same time, analysis of materials of economic activity of joint ventures in the Republic of Karakalpakstan also show that not everything is going positively in this case.

Unfortunately, there are enterprises that could not start production activities for a number of reasons and were liquidated by the decision of the Economic Court. As the research materials show, the reasons for stopping the activities of these JVs were systematic violation of legislation and failure to fulfill their statutory obligations.

Conclusion

The data analysis shows that in the second half of the 1990s, economic policy in Karakalpakstan was aimed at transforming the industrial sector and developing new industries. The adoption of the concept of industrial development and the implementation of structural reforms in the economy set a number of ambitious tasks for the region, such as diversifying the economy, increasing the production of finished goods and ensuring competitiveness in the market.

Economic transformation led to the creation of new enterprises and the development of sectors such as fuel and food industries. An important aspect was the attraction of foreign capital and the establishment of joint ventures, which helped to modernize production and improve the quality of products.

However, there were obstacles to economic development, including systematic violations of legislation and financial difficulties, which led to the liquidation of some enterprises.

Overall, the article reflects important stages in the economic development of Karakalpakstan in the 1990s. In doing so, it highlights both the successes and the challenges that the region faced in the process of structural transformation.

References:

- Bektemirov, K. Industry of Karakalpakstan in the course of reforms // Economics and Statistics – No. 7. 1996.
- “Concept of the main directions of development of economy and social sphere of Karakalpakstan for 1993–2000 and for the period up to 2005”.
- Bektemirov, K. “Sustainable development of regions of ecological crisis: methodology and tools of application in the Aral Sea region”.– Tashkent, “Fan”, 2006.– 20 p.
- Bektemirov, K. Industry of Karakalpakstan in the course of reforms // Economics and Statistics – No. 7. 1996.
- Decree of Jokargy Kenes of the Republic of Karakalpakstan from 7.07.92 № 125.
- Decree of the Council of Ministers of the Republic of Karakalpakstan from 14.09.92 year № 221/9.
- “Karakalpakstan tariykhy” (1991–2015-zhyllar) Nukus: Ilim, 2018 Authors: Candidate of Historical Sciences A. Jumashev, Candidate of Historical Sciences S. Nurzhanov, Candidate of Historical Sciences L. Urazova, R. Tajieva, Kamalov S. K., Koshchanov B. A. Problems of History of the XX century // Vestnik KK FAN Ruz. 1996.– No. 2.– 41 p.

submitted 10.02.2024;
accepted for publication 28.02.2024;
published 18.03.2024
© Ktaybekov A.
Contact: ktaybekov@gmail.com



Section 6. Technical science in general

DOI:10.29013/AJT-24-1.2-58-62



STUDY OF THE PROCESS OF DRYING NATURAL GAS USING GLYCOLS USING MULTIFUNCTIONAL ADDITIVES AND AZEOTROPIC SOLVENTS

*Makhmudov M.J.*¹, *Elmurodov E. Yu.*²

¹ Bukhara Institute of Engineering and Technology, Bukhara, Republic of Uzbekistan

² University of economy and pedagogy, Karshi, Republic of Uzbekistan

Cite: *Makhmudov M.J., Elmurodov E. Yu. (2024). Study of the Process of Drying Natural Gas Using Glycols Using Multifunctional Additives and Azeotropic Solvents. Austrian Journal of Technical and Natural Sciences 2023, No 11-12. <https://doi.org/10.29013/AJT-24-1.2-58-62>*

Abstract

This article presents experimental results on the effect of azeotropic solvents and poly-functional additives in the drying of natural gas with glycols. The addition of hydrocarbon azeotropic solvents to the glycol recovery system increases the TEG concentration and reduces the moisture content of the glycol. The addition of azeotropic solvents to the glycol recovery system increases the concentration of TEG and reduces the viscosity of the glycol. A regeneration scheme has been developed by adding 0.10–0.30 kg of petroleum ether per 1 kg of glycol to a desorber in an absorption drying apparatus for natural and satellite gases.

Keywords: *gas dehydration, gas, glycol, triethylene glycol (TEG), diethylene glycol (DEG), azeotrope, azeotropic distillation*

Introduction

In the gas industry, the process of drying moisture contained in gases using liquid absorbents (glycols) is widely used. This process consists of absorbing moisture with glycol, desorbing the regenerated glycol, and recycling. The depth of gas drying largely depends on the residual concentration of water in the glycol at the desorber outlet (Yuan, B., Sun, H., Wang, T., Xu, Y., Li, P., Kong, Y., Niu Q.J., 2016).

To increase the depth of recovery of glycol, the following methods are used: in-

creasing the temperature, decreasing the pressure, cleaning with dry gas and introducing a substance that forms an azeotropic mixture with water.

The main disadvantages of absorption drying (Maddox Rand, 2008; Manovyan, A. K. 2001):

- insufficient depth of water desorption, which reduces absorption efficiency;
- in the absorber of glycol foaming;
- acids formed as a result of degradation of glycols corrode devices;

- desorption during of glycol water steam with to disappear.

The purpose of this work is to improve the deep drying process of natural gas with glycols using an azeotrope forming agent and surfactants.

In our country, DEG is mainly used in the processes of drying hydrocarbon gases, while TEG is used in many countries of the world. TEG has several advantages over DEG in gas drying processes: its total loss rate is 2–3 times lower, TEG has relatively higher dew point depression, and less acid formation as a result of its regeneration (CY Pan AIChE Journal 1998.– #34). However, adapting the DEG regeneration device to the TEG is difficult due to the fact that their regeneration temperatures differ by 30–40 °C and requires considerable economic costs. We know that azeotropes lower the boiling point of solutions. Therefore, the use of these substances to adapt DEG to TEG in gas absorption dryers provides a significant cost reduction.

We calculated the boiling point of some hydrocarbon mixtures with water according

to Antoine’s equation. Since the mutual solubility of hydrocarbons and water is less than 0.2%, an immiscible component model was used for the calculation. The results are presented in Table 1.

As shown below, the boiling point of the hydrocarbon-water mixture is almost identical to the experimental results of the boiling temperature of the hydrocarbon-water-TEG mixture. Consequently, the boiling temperature of the hydrocarbon-water mixture is almost unaffected by TEG. As can be seen from the results of Table 1, the calculated temperature of the hydrocarbon-water mixture exceeds 100 °C for some components. For example, this indicator for decan exceeds 132.7 °C.

Our experiments have shown that, in fact, the boiling point of the n-decane-water mixture is in the range of 97–100 °C. Thus, the results of the study showed that the effect of glycol in the presence of TEG in the calculation of the boiling phase equilibrium of azeotropic hydrocarbon-water mixtures is not significant.

Table 1. Calculation of boiling temperature of “Hydrocarbon – Water” and “Hydrocarbon – Water – TEG” mixtures and comparison of experimental results

Hydrocarbon	Boiling temperature, °C		
	“Hydrocarbon – Water-TEG” mixture calculation	“Hydrocarbon – Calculation of water” mixture	“Hydrocarbon – Results in literature for water” azeotrope mixture (Bekirov T.M., Lanchakov G.A. 1999)
Pentane	35.9	34.5	34.4
Hexane	66.9	61.6	61.6
Heptane	91.9	79.2	79.2–79.6
Octane	11.2	89.4	89.4–89.6
Dean	133.0	97.6	97.3
Isooctane	93.0	79.4	78.9
Cyclohexane	78.1	69.4	69.4
Benzene	77.2	70.0	69.4
Toluene	100.9	84.5	84.1–81.5
Ethylbenzene	117.2	92.0	89.0–92.0

A comparative analysis of the amount of azeotropic solvents needed to distill the same amount of water is of practical interest. The results of such calculations are summarized in Table 2.

We know from literature sources that C+ hydrocarbons form azeotropic mixtures with TEG at atmospheric pressure, and the more carbon atoms in the hydrocarbon, the greater the concentration of TEG in the azeotrope. Thus, it can be concluded that during azeo-

tropic distillation of hydrocarbon-water-glycol mixtures, the use of low molecular weight hydrocarbons with a number of carbon atoms not exceeding $C_7 - C_8$ is the most beneficial, as this reduces glycol losses. However, Table 2 shows that the more carbon atoms in a hydro-

carbon, the less water is required for complete distillation. Therefore, it is possible to use hexane-heptane fraction or petroleum ether boiling fractions in the temperature range of 70–100 °C as an alternative azeotropic agent in the regeneration process (Carroll, D. 2007).

Table 2. Calculation of the hydrocarbon mass of the “Hydrocarbon – Water” azeotropic mixture

Hydrocarbon	Calculation results		Results of water concentration in the azeotropic mixture in the literature, % mass (Echt W. I., Dortmund, D.D. and Malino, H. M.)
	Concentration of water in the azeotropic mixture, % mass	The ratio of 1 kg of hydrocarbon to 1 kg of water in an azeotropic mixture	
Pentane	1.5	70.5	1.5
Hexane	5.4	18.1	5.5
Heptane	13.0	7.0	12.9
Octane	24.9	3.2	25.5
Dean	58.5	0.6	51.0
Isooctane	11.7	7.8	10.9
Cyclohexane	8.5	11.0	8.4
Benzene	8.9	10.5	8.8
Toluene	19.8	4.3	13.5–20.2
Ethylbenzene	33.2	2.1	30.6–33.0

The effect of azeotropic hydrocarbon scavengers on TEG drying rate and its regeneration was investigated using a Dina-Stark extraction-distillation laboratory unit and simple atmospheric distillation.

From the label, the following were selected as additives that increase the degree of water blowing: n-heptane, n-decane, isooctane, cyclohexane, toluene, petroleum ether (40–70), petroleum ether (70–100), nitrogen. The selection of these hydrocarbons is related to the task of testing the behavior of each of the hydrocarbon classes (n-alkanes, isoalkanes, cycloalkanes and aromatic hydrocarbons) for the degree of water distillation from triethylene glycol.

The research carried out by us consisted of checking the correctness of the developed theoretical concepts and calculations, namely: testing petroleum ether (70–100) as an alternative hydrocarbon solvent that forms an azeotrope forming a mixture with water in solution with TEG and 1 kg of glycol at a temperature of 165 °C for (70–100) is to determine the optimal concentrations of petroleum ether.

A gas-adsorption chromatography method was used to determine the amount of water in low concentrations in TEG.

Table 3 presents the results of atmospheric distillation studies of water-TEG mixture in Dina-Stark device by adding different hydrocarbon agents. Each study was conducted for 1 hour at temperatures between 160–180 °C.

Table 3. Results of hydrocarbon mass calculation in hydrocarbon-water azeotrope mixture

Naming	Boiling temperature of hydrocarbon, °C	Boiling temperature of the mixture, °C	Amount of remaining moisture in TEG, % mass
Without carbohydrates	–	100–105	2.85

Naming	Boiling temperature of hydrocarbon, °C	Boiling temperature of the mixture, °C	Amount of remaining moisture in TEG, % mass
Petroleum ether i (40–70)	40–70	35–66	0.74
Cyclohexane	81.0	70.0	0.48
n – Heptane	98,2	79.0	0.14
Isooctane	99	79,1	0.12
Petroleum ether i (70–100)	71–100	75–94	0.12
Toluene	112	85	0.51
n – Dean	175	98	1.11

As can be seen from Table 3, all hydrocarbons form azeotropic mixtures with water, and when heated, more moisture can be extracted from the glycol without the addition of solvents.

The minimum water content in TEG was obtained using isooctane and petroleum ether fraction 70–100. With the addition of these hydrocarbon solvents, residual concentrations as low as 0.1% by weight of water can be achieved by azeotropic rectification of TEG. Although toluene gives good results, it is not advisable to use this class of hydrocar-

bons as an azeotroping agent because TEG is highly soluble in aromatic hydrocarbons.

Based on the data in Table 3, it showed that hydrocarbons boiling at temperatures of 70 and 100 °C give positive results. Since petroleum ether is cheaper than individual hydrocarbons, its use in the glycol recovery process is the most economically feasible.

To determine alternative concentrations of petroleum ether (70–100) as an azeotroping agent, we conducted a series of driving experiments with petroleum ether–water–TEG mixtures in a Dina–Stark laboratory setup. The results of experiments are presented in Table 4.

Table 4. Effect of different concentrations of petroleum ether on azeotropic driving of water-TEG solutions

TEG mass, g	Water mass, g	(70–100) mass of petroleum ether, g	Amount of petroleum ether		The amount of water remaining in TEG after driving, % mass
			Saturated TEG kg/kg	Water kg/kg	
90	10	10	0.08	1.0	0.14
50	5	6	0.15	2.0	0.12
50	5	12	0.28	6.0	0.16
50	5	18	0.50	12.0	0.25

Table 4 shows that the addition of 0.08–0.28 kg (70–100) of petroleum ether to saturated glycol, 1 kg of absorbent, is 0.14–0.16% by mass in the regenerated absorbent. ensures water retention.

It has been proved by the authors of a scientific study (Carroll, D., 2007) that it is possible to achieve a residual concentration of up to 2.8% by weight of water by simple distillation of a water-TEG mixture under

laboratory conditions (Carroll, D., 2007). Results in a scientific study confirmed that the maximum limit of water evaporated from TEG that can be achieved by heating temperature and atmospheric distillation is a concentration in the range of 1.3–2.0% by weight of TEG.

We also conducted experiments on the simple distillation of water – TEG mixtures with the addition of nitrogen and petro-

leum ether (70–100). The results obtained with distillation in the presence of nitrogen showed a residual water content of 0.79% by weight, and with nitrogen distillation and the addition of petroleum ether it was 70–100–0.56% by weight.

These obtained results proved the principle that the addition of inert gas in the driving has a positive effect on the TEG composition than driving water under normal atmospheric conditions. Nevertheless, the amount of residual water in the glycol remains higher than using azeotropes and without nitrogen addition. This can be explained by the fact that in normal distillation there is no constant return of petroleum ether (cold water) to the flask. The circulation of the azeotropic solvent in the Dina-Stark laboratory appara-

tus is the same as in the rectification column. This provides multiple mass exchanges between the hydrocarbon and water-TEG mixture and, accordingly, gives a low residual concentration of water in the mixture.

Thus, as a result of the conducted research, the following conclusions can be made: an alternative azeotrope-forming hydrocarbon solvent (70–100) that increases the depth of water desorption in TEG regeneration plants is petroleum ether. The use of this substance allows lowering the reboiler temperature in the desorption unit to 165–175 °C, and at the same time increases the evaporation of water from the mixture to 0.1% by weight. This, in turn, enables the conversion of gas drying plants from DEG to TEG, resulting in significant savings in operating costs.

References

- Yuan, B., Sun, H., Wang, T., Xu, Y., Li, P., Kong, Y., Niu Q. J. Propylene/propane permeation properties of ethyl cellulose (EC) mixed matrix membranes fabricated by incorporation of nanoporous graphene nanosheets // *Scientific Reports*. 2016. – Vol. 6. – 28509 p.
- Maddox Rand. MJ Gas conditioning and processing. – Vol. 4. Gastreating and sulfur recovery. 2008. – No. 3.
- Manovyan, A. K. Technology of primary processing of oil and natural gas. 2-e izd. – M.: Khimiya, 2001. – 568 p.
- CY Pan AIChE Journal 1998. – #34.
- Bekirov, T. M., Lanchakov, G. A. Technology processing gas and condensate. – M.: Nedra-Biznestsentr. 1999. – 596 p.
- Echt W. I., Dortmund, D. D. and Malino, H. M. Proceedings of the 52nd Laurance Reid Gas Conditioning Conference.
- Carroll, D. Hydraty natural gas. Per. English – M.: ZAO “Premium Injiniring”. 2007. – 316 p.

submitted 18.01.2024;

accepted for publication 02.02.2024;

published 18.03.2024

© Makhmudov M. J., Elmurodov E. Yu.

Contact: makhmudov.mukhtor@inbox.ru



DOI:10.29013/AJT-24-1.2-63-67



THE MAIN DIRECTIONS OF NATURAL GAS PROCESSING IN THE CHEMICAL INDUSTRY

Makhmudov M.J.¹, Elmurodov E. Yu.²

¹ Bukhara Institute of Engineering and Technology, Bukhara, Republic of Uzbekistan

² University of economy and pedagogy, Karshi, Republic of Uzbekistan

Cite: *Makhmudov M.J., Elmurodov E. Yu. (2024). The Main Directions of Natural Gas Processing in the Chemical Industry. Austrian Journal of Technical and Natural Sciences 2023, No 11-12. <https://doi.org/10.29013/AJT-24-1.2-63-67>*

Astract

The chemical industry is one of the main consumers of natural gas. Natural gas is used in the chemical industry, on the one hand, as a source of energy, on the other hand, as a source of raw materials for a large number of chemical industries. The main part of natural gas is used as a source of raw materials, converted into synthesis gas, which includes carbon monoxide and dioxide, hydrogen, unreacted methane and a small amount of impurities contained in natural gas (nitrogen, argon, etc.).

Keywords: *gas, gas chemistry, methanol, Fischer-Tropsch, synthesis gas, adsorption, absorption*

Introduction

Currently, all natural hydrocarbon gases go through two stages of primary processing:

- preparation of gas for processing, including their purification from mechanical impurities, from undesirable chemical compounds, primarily acidic, and drying. When cleaning gases from chemical impurities, various sorption (absorption, adsorption, chemisorption), catalytic (hydrogenation, hydrolysis, oxidation) and membrane cleaning methods are used. After the extraction of hydrogen sulfide, it is processed into elemental sulfur by the Claus method. Gas dehydration can be carried out by various methods: di-

rect cooling, absorption, adsorption or their combination;

- separation of gases, starting with the separation of suspended liquids by low-temperature separation, extraction of liquid hydrocarbon components by compression and oil absorption, as well as various low-temperature methods (low-temperature absorption – LTA, low-temperature condensation – LTC, low-temperature rectification – LTR, low-temperature adsorption – LT-adsorption) leading to the production of unstable gas gasoline and reflux – raw materials for the production of liquefied gases and individual hydrocarbons.

The next stages of the physical processing of hydrocarbon gases are the separation of hydrocarbon gases into individual hydrocarbons and the separation of helium, mainly by cryogenic means, followed by concentration and liquefaction, as well as the stabilization of gas gasoline and gas condensate carried by gas from the well.

These processes make it possible to obtain commercial products that meet the necessary requirements. As a result of the primary processing of natural hydrocarbon gases, commercial gas, fuels (motor gasoline, diesel and boiler fuel), stable gas condensate, liquefied gas, gas sulfur, odorant, carbon black, helium are obtained, individual hydrocarbons are isolated for further processing.

However, at present, the use of useful gas components in our country does not meet the potential of the resource base and does not correspond to world practice. Therefore, the concept of gas feedstock processing is fundamentally reviewed, taking into account possible directions for its chemical processing, based on an analysis of the state of operation and loading of existing capacities for processing gas resources and gas condensate feedstock in Russia.

Hydrocarbons released from gas are a valuable raw material for the production of various chemical products. Chemical processing of natural gases makes it possible to obtain a wide range of valuable products: motor fuels, medical and agricultural preparations, polymeric materials, large-capacity products such as methanol, ammonia, acetylene, and halogen derivatives. In turn, dozens of chemical compounds are produced on the basis of ammonia, methanol, acetylene: urea, formaldehyde, urea-formaldehyde resins, high-octane gasoline components; methyl tert-butyl ether, melamine and resins based on it, nitrogen fertilizers.

Thus, the problem of complex chemical processing of natural gas, which provides for the qualified use of all its components, is very relevant.

The most important practical use of the chemical processing of natural gases has two directions (Konovalov, N.M., Voinov, N.A., Markov, V.A., Nikolaev, N.A., 1993):

1. Thermal and thermocatalytic transformations of natural gas components. These

are the processes of pyrolysis and dehydrogenation, leading to the formation of unsaturated hydrocarbons – acetylene, olefins, dienes, which are widely used for the production of various macromolecular compounds and oxygen-containing products. A new process being developed within this direction is the production of aromatic hydrocarbons from gas components $C_3 - C_4$.

2. Oxidative transformations of light hydrocarbons – components of natural gases, primarily the conversion of methane into synthesis gas and the production of such important chemical products as methanol, formaldehyde, dimethyl ether, acetic acid and other carboxylic acids, aliphatic alcohols, synthetic hydrocarbons. This trend also includes a new process, the oxidative dimerization of methane to ethylene.

The development of new industrial technologies for thermal and thermal catalytic transformations of natural gas components was aimed at developing pyrolysis technology in the presence of heterogeneous catalysts (catalytic pyrolysis) and initiating additives; creation of new types of pyrolysis – hydro-pyrolysis, oxypyrolysis and pyrolysis in the melt of metals and their salts; electrocracking, plasma pyrolysis. Unfortunately, success in these areas has been achieved only on the scale of enlarged laboratory and pilot plants, but not on industrial scale.

Of great interest is the one-stage catalytic synthesis of aromatic hydrocarbons from $C_2 - C_5$ alkanes, components of natural gas. This way of obtaining aromatic compounds – valuable intermediates for the production of polymers, synthetic fibers, dyes and pharmaceuticals – is an alternative to the process of catalytic reforming of petroleum fractions. Studies of the catalytic transformations of low molecular weight paraffinic hydrocarbons have been intensively carried out in recent years in many research centers both here and abroad. The work carried out under the direction of A. L. Lapidus revealed the most promising catalytic systems – zeolites of the pentasil family (Konovalov, N.M., Voinov, N.A., Markov, V.A., Nikolaev, N.A. 1993; Ershov A.I., 1975).

Oxidative transformations of lower paraffinic hydrocarbons, taking into account the complexity and low selectivity of their

direct oxidation, are aimed at obtaining valuable chemical products based on synthesis gas (a mixture of carbon monoxide and hydrogen in various proportions) obtained by methane conversion.

Syngas production

The main modern methods for producing synthesis gas from methane are as follows (Konovalov, N.M., Voinov, N.A., Markov, V.A., Nikolaev, N.A. 1993):

1. Steam conversion:

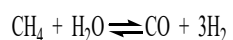

2. Carbon dioxide conversion:

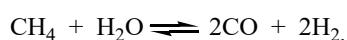

3. Partial oxidation:

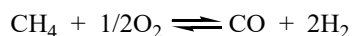

A new direction is the combination of endothermic processes (1 and 2) with the exothermic reaction of methane oxidation.

The most promising technologies for the production of synthesis gas are currently considered the so-called Tandem process – a two-stage steam-oxygen conversion of natural gas in two tubular reactors, and for large-capacity production – autothermal reforming (ATR) in the reactor, in which the partial combustion of the feedstock is accompanied by thermal and catalytic steam reforming of the feedstock. The latter process makes it possible to optimize the composition of the synthesis gas, taking into account its further processing into liquid hydrocarbons, methanol or dimethyl ether. Membrane methods for controlling the CO: H ratio in synthesis gas using polymeric membranes selectively permeable to hydrogen have been developed and are being implemented.

In Russia, NPO “Energomash” them. V.P. Glushko in collaboration with the Institute of Chemical Science of the Russian Academy of Sciences and NIFKhI im. L. Ya. Karpov developed a technology for producing synthesis gas using liquid-propellant rocket engines. This process requires the use of commercially pure oxygen and elevated pressure, but allows for high productivity, smaller reactor dimensions, its mass, metal consumption, and capital intensity compared to other technologies for producing synthesis gas. INHS RAS and

ICT RAS proposed a process for obtaining synthesis gas from methane in a diesel engine. A set of studies on the conversion of methane to syngas in plasma and stationary microwave discharge has been carried out at the RRC “Kurchatov Institute” (Ershov, A.I. 1975).

Tropsch process

The process of obtaining hydrocarbons based on carbon monoxide and hydrogen on iron and cobalt catalysts was developed long before the era of the appearance of cheap oil – in 1923 – by Fischer and Tropsch. The first industrial plants were commissioned in Germany. With the advent of cheap oil on the world market, the production of artificial fuel was almost universally discontinued. Recently, interest in this process has increased in many countries, including Russia.

The main direction of the process can be represented by a diagram (Klein, H., Schmidt, P., 1971):

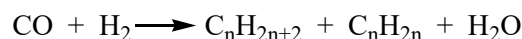

Very important factors for the development of this process are the increase in the productivity of LCL synthesis units, the selectivity of the process for liquid hydrocarbons, as well as an increase in the octane number of gasoline and cetane – diesel fractions. For this process, an increase in the productivity of plants is primarily associated with an increase in the activity of catalysts and an improvement in heat removal. Scientists from the Institute of Chemical Physics of the Russian Academy of Sciences and the Department of Gas Chemistry of the Russian State University of Oil and Gas are successfully developing new efficient catalysts for this process under the guidance of Corresponding Member. RAS A. L. Lapidus.

Production of methanol and chemical products based on it

Methanol is a valuable large-capacity product that is widely used in various industries. The volume of methanol consumption in the world is continuously increasing. At present, its world production exceeds 40 million tons/year. Almost the only industrial method for the production of methanol at present is to obtain it from synthesis gas by the reaction:

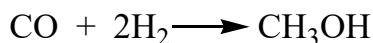

The synthesis of methanol is a well-established process in industry, however, in the late 1970s, new prospects for improving the technology opened up when copper-containing catalysts were developed that were effective at low pressure. As a result, methanol synthesis is currently carried out at pressures of 50–100 atm in almost all industries.

Methanol consumers are the production of formaldehyde, monomers (for example, methyl methacrylate and dimethyl terephthalate), methyl tertiary butyl ether (MTBE), dimethyl ether (DME), acetic acid. Methanol is widely used as a solvent and extractant, and a process has been developed to produce gasoline from methanol. Pilot work is being carried out on the processing of methanol into olefins, the oligomerization and hydrogenation of which make it possible to organize the production of motor fuels.

A new direction in the production of formaldehyde instead of the industrial process of oxidative conversion of methanol is the one developed by Mitsubishi Gas methanol dehydrogenation process on a copper-zinc-selenium catalyst at 600 °C (Melnikov, E.P., 1975):



The process of methanol dehydrogenation has not yet been implemented in industry, but it is very promising, as it makes it possible to obtain water-free formaldehyde and hydrogen. In addition, the methanol-formaldehyde mixture formed in the process can be processed without separation. Therefore, scientific research is currently being intensively conducted to find effective catalytic systems for this process.

DME, considered as a promising environmentally friendly diesel fuel, is obtained in three stages: the production of synthesis gas from natural gas, then methanol, and at the third stage, dimethyl ether is obtained by dehydration of methanol. Such a three-stage process is complicated and expensive, but the fundamental possibility of obtaining DME from synthesis gas in one stage under mild conditions and with high ether selectivity has been shown. DME is a promising raw material for the production of hydrogen-containing gas to power fuel cells (FCs). Currently,

the object of intensive research is the study of catalytic methods for producing hydrogen from DME for its production and use directly in car engines.

Obtaining methyl tertiary butyl ether (MTBE)

An important place among the new methanol processing processes implemented in the industry is occupied by the production of methyl tertiary butyl ether (MTBE). It is used as a high-octane component of motor fuels. MTBE is produced from methanol and isobutylene by the reaction

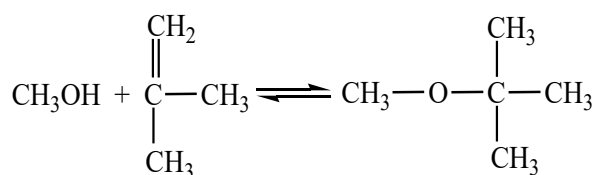

Given the limited resources of isobutylene, a process has also been developed for the production of methyltertamylyl ether (MTAE) from isoamylenes and methanol. The octane number of MTAE is 6 points lower than that of MTBE, but the involvement of isoamylenes makes it possible to expand the production of high-octane gasoline components.

Oxidative dimerization of methane (ODM)

This direction makes it possible to carry out the chemical processing of natural gas with the formation of ethylene and ethane, bypassing the stage of obtaining synthesis gas. The main ODM reactions leading to the formation of target products are the following (Isakov, V. P., Sugak, E. V., 1982):

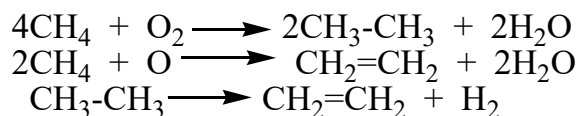

The course of the reaction is complicated by a significant non-selective consumption of methane for the formation of carbon oxides. Therefore, an important scientific and practical task facing researchers is the development of new affordable, stable catalysts that provide high selectivity for ethane and ethylene at a sufficiently high methane conversion. Efficient catalytic systems for this process are being successfully developed at

VNIIOS (V.A. Menshov), at the Institute of Organic Chemistry of the Russian Academy of Sciences (N. Ya. Usachev), and at the Russian State University of Oil and Gas (A. G. Dedov, A. S. Loktev).

Of great interest is also the processing of lower unsaturated hydrocarbons obtained by pyrolysis or dehydrogenation of natural gas hydrocarbons into polymeric materials: polyolefins and plastics based on them, synthetic rubbers.

We focused only on the development of gas-chemical industrial technologies for the processing of hydrocarbon components of natural gases; in recent years, much has been

done to develop rational technologies for the processing of hydrogen sulfide, mercaptans, carbon dioxide, and the use of helium.

Already now, a number of gas processing plants are considering promising areas for the chemical processing of gas and gas condensate raw materials to obtain valuable products.

The development of gas chemical production facilities makes it possible to obtain a variety of chemical products that are widely used in a number of industries: mechanical engineering and automotive, construction, electronics, as well as medicine, agricultural complexes, and the production of household goods.

References

- Konovalov, N.M., Voinov, N.A., Markov, V.A., Nikolaev, N.A. Massootcha pri svobodnom stekanii filmi jidkosti po narujnym i vnutrennim poverkhnostyam trub // Teor. basic chemical technology 1993.– No. 3.– P. 309–314.
- Ershov, A. I. Razrabotka, issledovanie i primenenie elementnyx stepeney kontakta s vzaimod-eystviem phase v zakruchennom potoke. Dis. ... Dr. tech. science – L., 1975.– 304 p.
- Klein, H., Schmidt, P. Vergleichende Untersuchungen zwischen Drehstromungsentstauber und Zyklon // Verfahrenstechnik. 1971.– Bd. 5.– No. 8.– P. 316–319.
- Melnikov, E. P. Vikhrevye pyleuloviteli. Obzornaya informatsiya – M., 1975.– 45 p.
- Isakov, V. P., Sugak, E. V. Condensation Centrifugal Separator // Promyshlennaya i sanitarnaya ochistka gasov. 1982.– No. 6.– P. 2–4.

submitted 19.01.2024;

accepted for publication 02.02.2024;

published 18.03.2024

© Makhmudov M.J., Elmurodov E. Yu.

Contact: makhmudov.mukhtor@inbox.ru



DOI:10.29013/AJT-24-1.2-68-72



ANALYSIS OF CATHODIC PROTECTION STATION WITH THE FUNCTION OF SEARCHING FOR THE MAXIMUM POWER POINT OF A PHOTOVOLTAIC MODULE

*Ergashev Sirojiddin Fayazovich*¹, *Khudoyorov Khayotjon Dilshodjon oqli*¹

¹ Fergana polytechnic institute, Uzbekistan

Cite: Ergashev S. F., Khudoyorov Kh. D. (2024). Analysis of Cathodic Protection Station With The Function of Searching for the Maximum Power Point of a Photovoltaic Module. Austrian Journal of Technical and Natural Sciences 2023, No 11-12. <https://doi.org/10.29013/AJT-24-1.2-68-72>

Abstract

Solar energy can be effectively used in the construction of power supply systems for cathodic protection installations. A properly designed photovoltaic system will avoid costly expansion of the electrical grid, or the use of hydrocarbon-fueled generators, which have high maintenance costs due to the need for maintenance and refueling. The article discusses the characteristics of photoelectric converters as power sources for cathodic protection stations, and proposes and analyzes options for circuit implementation.

Keywords: *cathode potential, photovoltaic modules, reducing power converter, point maximum power, charge-discharge controller*

Introduction

The formation of defects in the insulating coating of a metal pipeline and exposure of the pipe metal is protected against corrosion by an electrochemical protection system (ECP). This type of protection is called active. The essence of ECP protection is the artificial polarization of the pipeline (cathode) in such a way that its potential shifts to the negative side. As a result of a shift in the cathode potential to the negative side, the work of the corrosion couple stops. But it is necessary to take into account that this can only happen with a potential within certain limits and an appropriate strength of the protective current. Protective polarization of the cathode can be achieved by applying a protective potential from a direct current

source or by using materials whose intrinsic potential is more negative than the cathode material as an additional anode.

Research method

The implementation of cathodic protection in areas remote from centralized power supply networks causes great difficulties due to the fact that its implementation requires the construction of power lines along the pipeline route.

During development conversion equipment based on power electronics, designing distributed generation facilities, creating and operation of power plants, operating on the basis of solar energy, it is necessary to take into account the existing general require-

ments for objects generation and international standards and rules taking into account the specifics functioning of distributed energy sources in power systems.

Depending on the type and scale of the distributed generation (DG) project, their conversion parts are divided into:

- autonomous (off-grid) installations with a power of up to hundreds of kilowatts, supplying single- or three-phase loads at remote sites in the absence of external power grids, including photovoltaic modules and a storage battery;
- grid-tie installations from units of kilowatts and power plants to hundreds of mega-

watts, and providing synchronous power delivery to distribution power grid, control of mode parameters, integration of renewable energy generating facilities and their monitoring, protection and management systems into the energy system;

- hybrid installations that combine the capabilities of the first two types and ensure parallel operation of several different types of sources of comparable power (SPP, WPP, micro-HPP, diesel generators and energy storage systems (ESS)). Block diagram of an autonomous solar power plant is shown in Fig. 1.

Figure 1. Block diagram of an autonomous solar power plant

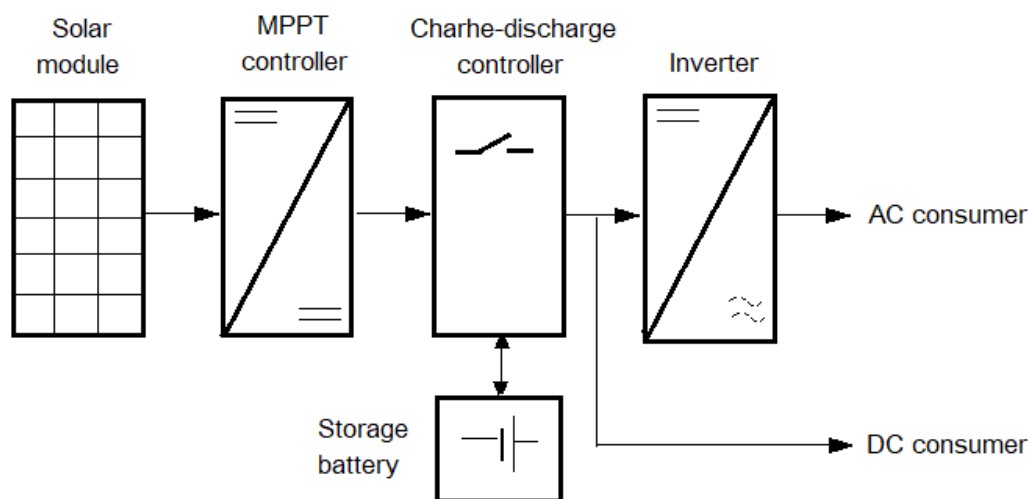

At remote sites or in isolated energy areas, the greatest interest is in autonomous hybrid installations (microgrid), including photovoltaic modules, wind turbines and backup diesel generators, which together provide reliable round-the-clock power supply to consumers, minimal fuel consumption (savings up to 90% compared to conventional diesel generator sets) and efficient use of battery life (charge/discharge cycles) and diesel generator sets.

Autonomous solar power plants (SPP) include:

- energy source — a group of low-power solar panels;
- MPPT controller (DC-DC converter), which controls the operating mode of the source to select its power at the maximum point (Maximum Power Point Tracking), providing a normalized output voltage;

- matching charger for storage batteries with voltage DC12/24/48 V (domestic and small commercial installations) or 96 V and higher (industrial installations);

- a group of series-parallel connected storage batteries of the required voltage and capacity;

- an autonomous inverter that converts the battery voltage together with the isolation transformer to a standard level to power the AC load.

Results analysis

As part of photovoltaic power plants, they are assembled into serial chains or, if necessary, in parallel, several strings with a maximum voltage of DC24–250 V (domestic installations) or 600/1000/1500 V (industrial), which are connected to the input of the MPPT controller. The number of PV modules in the

chain is limited by the open circuit voltage (V_{oc}) under conditions of a combination of maximum instantaneous insolation and minimum temperatures in the area where the solar power plant is located, taking into account the negative temperature coefficients characteristic of PV modules (on average $-0.45\%/^{\circ}\text{C}$ in power and $-0.35\%/^{\circ}\text{C}$ at open circuit voltage).

In order to increase the efficiency of the cathodic protection (CP) station, in a photovoltaic power supply system it is necessary to monitor the maximum power point of the photovoltaic module. The principle of construction and operation of the cathodic protection (CP) station, which ensures the selection of maximum power, is illustrated by the diagram in Fig. 2.

Figure 2. Installation diagram of cathodic protection with the function of tracking the maximum power point of solar panels

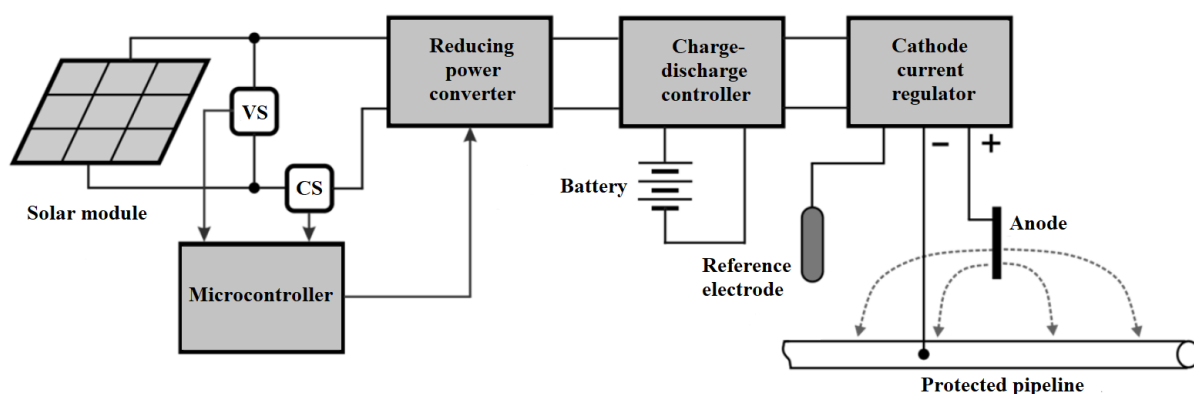

The power section of the circuit, in addition to the PV module, includes a reducing power converter, a cathode current regulator, and a battery with a charge-discharge controller.

The reducing power converter is made according to the circuit shown in Fig. 3. The VT power switch is controlled through the driver by a signal that comes from a microcontroller with a search function for the maximum power point.

Figure 3. Reducing power converter circuit voltage

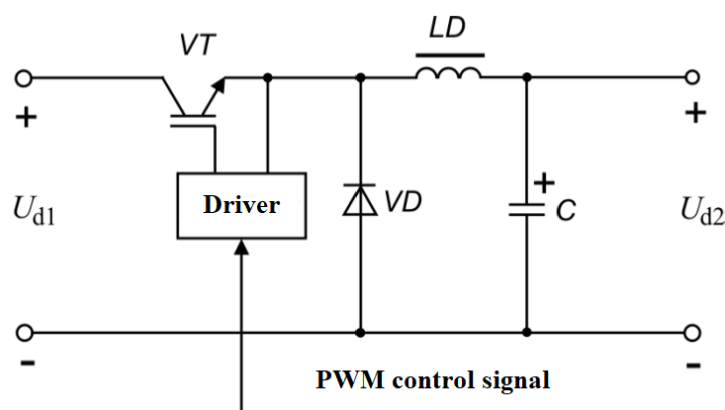

The clock frequency f_0 of the pulse converter depends on the dynamic properties of the power switches on which the converter is made.

Voltage U_{d1} is supplied from the output PV module. Adjustment of output voltage U_{d2} and change in equivalent resistance load for

the solar panel occurs due to the Pulse Width Modulation (PWM).

Average voltage U_{d2} at output of the pulse converter depends on the input voltage U_{d1} and parameter D , which is equal to pulse duration ratio voltage at the pulse output converter to cycle duration T_0 , i.e.

$$D = \frac{\tau}{T_0} = \tau \cdot f_0 \quad (1)$$

Thus, the adjustment pulse characteristic DC/DC converter can be represented in the following form:

$$U_{d2} = \psi(D) \cdot U_{d1} \quad (2)$$

For a converter made according to diagram in Fig. 3, adjustment characteristic has the form:

$$U_{d2} = D \cdot U_{d1} \quad (3)$$

Information from voltage sensors VS and the CS current of the solar panel is supplied to microcontroller that implements PWM signal D controlling reducing power converter. At every stroke of work power $P_k = U_k \cdot I_k$ is calculated, selected from the PV module. Then it is produced comparison of the obtained P_k value with the value of P_{k-1} at the previous cycle. In addition, the signal is compared control D_k at a given control cycle with signal D_{k-1} at the previous step. Depending on

the signs received differences are adjusted control signal to high or the smaller side with a given discreteness ΔD_{k-1} . Thus, on every cycle of system operation the maximum point is searched for power taken from the PV module.

Simultaneously with searching for a point maximum power in the system power supply, the condition of the battery is monitored. When the battery is full charged, the controller disconnects it from solar panel, thereby preventing overcharging and premature failure.

Voltage U_{d2} is supplied to the cathode current regulator. The battery is also connected to pulse converter output voltage through the charge-discharge controller.

The cathode current regulator is designed as pulse buck-boost converter according to the diagram presented in Fig. 4. A feature of the circuit is that it allows, through PWM, not only to regulate the output voltage U_{d3} , but also to invert its polarity.

Figure 4. Cathode current regulator circuit

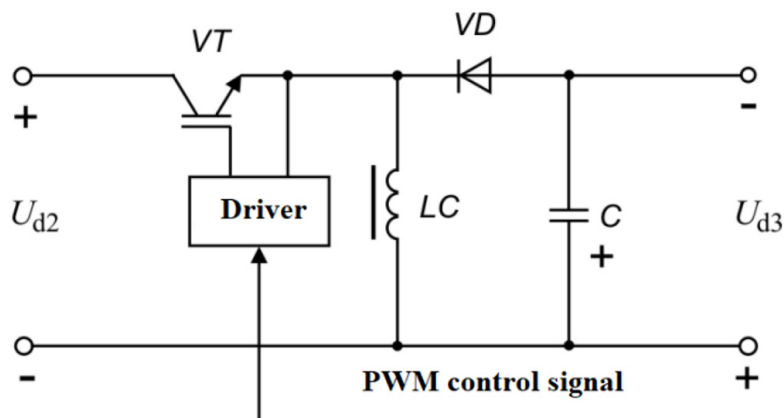

The control characteristic (2) for this converter has the form:

$$U_{d3} = \frac{D}{1-D} \cdot U_2 \quad (4)$$

From expression (4) it follows that when $D = 0,5$ the output voltage is equal to the input voltage, but has the opposite polarity.

If $D < 0,5$, then the output voltage is value less than the input voltage. And, conversely, when $D > 0,5$, the output voltage greater than the input voltage converter. Thus, by changing parameter D of the cathode current regulator, can provide the specified value potential on the protected pipeline.

Discussions

Each cathodic protection station, depending on the corrosive properties of the soil, the quality of insulation, and the power of the station itself, can protect the pipeline over a section of a certain length. Within this length, the protective potential created by the cathodic protection station ensures the absence of electrochemical corrosion on the cathode (pipeline). At the same time, the anode (grounding) is intensively destroyed due to the activation of the anodic process. The highest value of the potential difference within the length of the section is usually recorded opposite the anode, i.e. grounding.

Conclusion

This article analyzes the composition of the power part of the circuit of a cathodic protection station with power supply from renewable energy sources and, in particular,

from solar panels. We have proven that by changing parameter D of the cathode current regulator, can provide the specified value potential on the protected pipeline.

References

- Mishra, P. R., Joshi, J. C., Roy, B. “Design of a solar photovoltaic-powered mini cathodic protection system”, *Solar Energy Materials & Solar Cells* — 61. 2000.— P. 383–391.
- Wagdy, R., Anis, Hany A. Alfons. “Photovoltaic-powered regulated cathodic-protection system”, *Journal of Power Sources*,— 50. 1994.— P. 27–32.
- Mishra, P. R., Joshi, J. C., Roy, B. “Design of a solar photovoltaic-powered mini cathodic protection system, *Solar Energy Materials and Solar Cells*. 2000.— Vol. 61.— Is. 4.— P. 383–391. DOI: 10.1016/S0927–0248(99)00121-X.
- Tian, T., Xiao, S. “Electrochemical Anti-corrosion System of Iron Tower Based on Solar Power Supply”, *MATEC Web of Conferences*.— EDP Sciences, 2018.— Vol. 160.— P. 03006. DOI: 10.1051/matec-conf/201816003006.
- Chew, W.S. “Solar Power as an Alternative to Applied Current in a Cathodic Protection System. Graduate work”. Department of Civil Engineering, UTM, Johor,— Malaysia. 2005.
- U. S. Department of the Interior Bureau of Reclamation, “Corrosion and Cathodic Protection”, Denver, Colorado, www.usbr.gov, 2013.
- Ezz Eldin Balla Mohamed Hussein. “System Identification and Adaptive Self-tuning Control for Impressed Current Cathodic Protection System”. University Teknologi — Malaysia, Jan. 2013.

submitted 12.02.2024;
accepted for publication 28.02.2024;
published 18.03.2024
© Ergashev S. F., Khudoyorov Kh. D.
Contact: hayotbek_exp@mail.ru



DOI:10.29013/AJT-24-1.2-73-78



ANALYSIS OF CALCULATING THE POSITION OF THE SUN OVER CITIES OF THE REPUBLIC OF UZBEKISTAN

*Ergashev Sirojiddin Fayazovich*¹, *Oshepkova Elvira Axtemovna*¹

¹Fergana polytechnic institute, Uzbekistan

Cite: Ergashev S. F., Oshepkova E.A. (2024). *Analysis of Calculating the Position of the Sun Over Cities of the Republic of Uzbekistan. Austrian Journal of Technical and Natural Sciences 2023, No 11-12.* <https://doi.org/10.29013/AJT-24-1.2-73-78>

Abstract

An effective way to increase the productivity of photovoltaic installations is to use solar tracking systems. The pronounced dependence of the amount of solar radiation entering the receiving surface of solar panels on the geographical location of the power plant causes significant differences in the characteristics of solar radiation for different regions of Uzbekistan. The smaller the angle of the Sun's position above the horizon, the greater the path of solar radiation through the Earth's atmosphere, therefore, the loss of intensity of solar radiation in the atmosphere increases. Considering the above, this article is aimed at determining the position of the sun over the cities of the Republic of Uzbekistan located in different coordinates to justify the provision of photovoltaic installations with a tracking system.

Keywords: *Solar declination, geographical locations, azimuthal and altitude angles, optimal positioning*

Introduction

Of all the known renewable energy sources, one of the most popular and dynamically developing at present is photovoltaic technologies, the advantages of which include a long service life of the main energy components, minimal operating costs, and the ability to assemble solar installations that generate power as close as possible to the objects of electrical consumption (Ergashev, S.F., Tokhirov, M.K., Oshchepkova, E.A., 2021; Reda, I. and Andreas, A., 2004).

However, despite the obvious advantages, the limiting factors for the introduction of photovoltaic stations remain the high cost of purchased equipment and the low efficiency

of energy conversion. The use of a solar tracking system makes it possible to achieve an increase in the productivity of photovoltaic installations on average from 15 to 60%, depending on the type of tracker, the geographical location of the solar power plant and the time of year (Mousazadeh, H., Keyhani, A., Javadi, A., Mobli, H., Abrinia, K. and Sharifi, A. 2009; Saheli, R., 2012).

It is necessary to conduct a full analysis of the technical characteristics of the tracking system in the design of a photovoltaic station in accordance with the operating conditions: the range of movement of photovoltaic modules in azimuthal and altitude angles, the method and algorithm used for tracking the

position of the Sun and the maximum wind speed, etc.

Research method

One of the most important technical characteristics of solar photovoltaic power plants is the operating ranges of movement of the solar tracker in the azimuth and altitude angles of the sun, which should cover the maximum possible angle values in the planned location of the photovoltaic installations.

Fig. 1 shows the Earth with its axis around which it rotates every 24 hours. The Earth's axis is perpendicular to the Earth's equatorial plane. The Earth's surface is characterized by two main quantities: geographic latitude φ – the angle formed by a plumb line passing through a given point on the Earth's surface and the plane of the equator; geographic longitude ψ – the dihedral angle between the planes of the prime meridian and the meridian of a given point (Mahmood, O. T., 2013).

Figure 1. Movement of the Earth around its axis in space: δ – declination of the Sun, N – north pole, S – south pole, φ – geographic latitude, ψ – geographic longitude

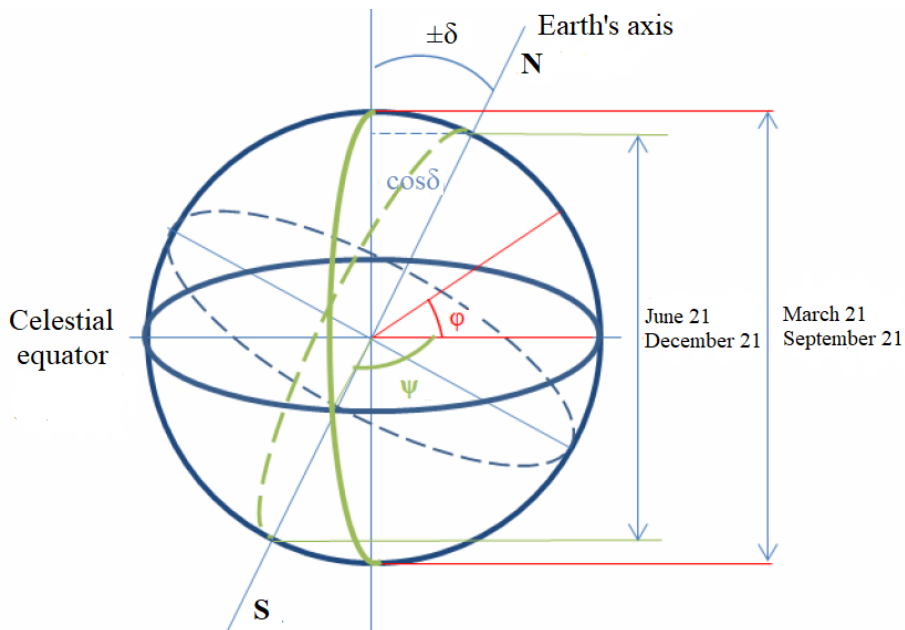

The angle between the sun's rays and the Earth's equatorial plane is the declination of the sun δ and is a measure of seasonal changes. Solar declination changes throughout the

year due to the tilt of the Earth's axis. On the day of the summer solstice, the Sun reaches its greatest positive declination, that is, it is located north of the celestial equator.

Figure 2. Diagram showing: θ – Solar Zenith Angle, h – Solar Altitude Angle, Az – Solar Azimuth angle

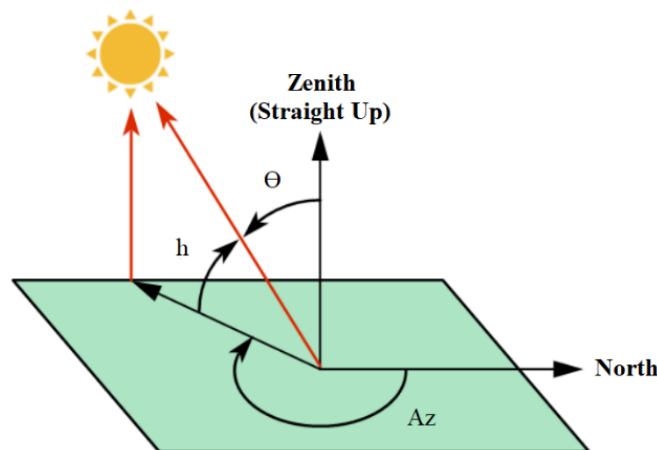

On the contrary, on the day of the winter solstice, the Sun reaches its greatest negative declination, being located south of the celestial equator (Francisco, D., Pedro, D.G., Luis, C.G., 2010; Nayak, S.R. and Pradhan, C.R., 2012). On the days of the spring and autumn equinoxes, the declination of the Sun is zero, since the Sun is at the celestial equator. The declination of the Sun can be calculated using equation of Cooper:

$$\delta = 23.45 \cdot \sin\left[\frac{360}{365}(N + 284)\right], \text{ degrees,} \quad (1)$$

where N is the number of the calendar day from the beginning of the year.

Solar Zenith Angle is determined by the formula:

$$\theta = \arccos(\sin(\varphi) \cdot \sin(\delta) + \cos(\delta) \cdot \cos(\varphi) \cdot \cos(\omega)), \text{ degrees,} \quad (2)$$

where φ – is the latitude of the area at the installation point of photovoltaic modules; δ – is the declination angle of the Sun, ω – Hour Angle, the difference between noon and the current time of day in terms of a 360° rotation in 24 hours.

The altitude angle of the Sun above the horizon h is determined by the expression:

$$h = 90 - \theta \quad (3)$$

The azimuthal position angle of the Sun Az is found from the equation:

$$Az = 180 - \arcsin((- \sin(\omega) \cdot \cos(\delta)) / (\cos(h))) \quad (4)$$

Results analysis

We compared the azimuthal and altitude angles of the sun hourly on the day of the summer solstice in four cities of Uzbekistan: Muynak (43.7683 N59.0214 E), Uchkuduk (42,1535 N63.5617 E), Termez (37.2242 N67.2783 E), Fergana (40.3842 N71.7843 E). The results are shown in the Table 1 and Figure 3. Cities were selected from extremely different geographical locations to compare the solar trajectory at different longitudes and latitudes. It is clear from the diagrams that in the middle northern latitudes the value of the sun's altitude angle during daylight hours varies within relatively large limits, especially in the summer months of the year, in particular the considered day of the summer solstice. Accordingly, for optimal positioning of the surfaces of photovoltaic modules on the Sun, it is necessary to change their inclination in a fairly wide range of angles. The city of Muynak has the lowest values of the solar trajectory for altitude and azimuth angles. Slightly higher on the graph is the solar trajectory of the cities of Uchkuduk, Termez and Fergana.

Table 1. Azimuthal and altitude angles of the sun by hour in the cities of Uzbekistan

Time of day (hours)	Muynak 43.7683 deg N. 59.0214 deg E.	Uchkuduk 42.1535 deg N. 63.5617 deg E.	Termez 37.2242 deg N. 67.2783 deg E.	Fergana 40.3842 deg N. 71.7843 deg E.
Sun altitude angle above the horizon, h (degrees)				
6:00	5.0311	7.2821	7.8568	12.2957
9:00	36.291	39.671	42.7192	45.9853
12:00	65.5869	68.8256	74.523	72.7719
15:00	58.9997	56.8076	55.649	51.5067
18:00	27.5739	24.0443	20.1742	17.6253
20:00	6.8968	3.2048	-1.7533	-2.9758
Azimuthal angle of the sun. Az (degrees)				
6:00	62.0258	64.8351	66.4574	69.57
9:00	91.1491	93.0807	91.2371	97.4024
12:00	141.0561	148.3904	150.6667	168.5139
15:00	238.3457	246.1865	256.92	256.6642
18:00	276.9574	280.5793	284.6564	286.1198
20:00	296.0349	299.1208	301.5326	304.5468

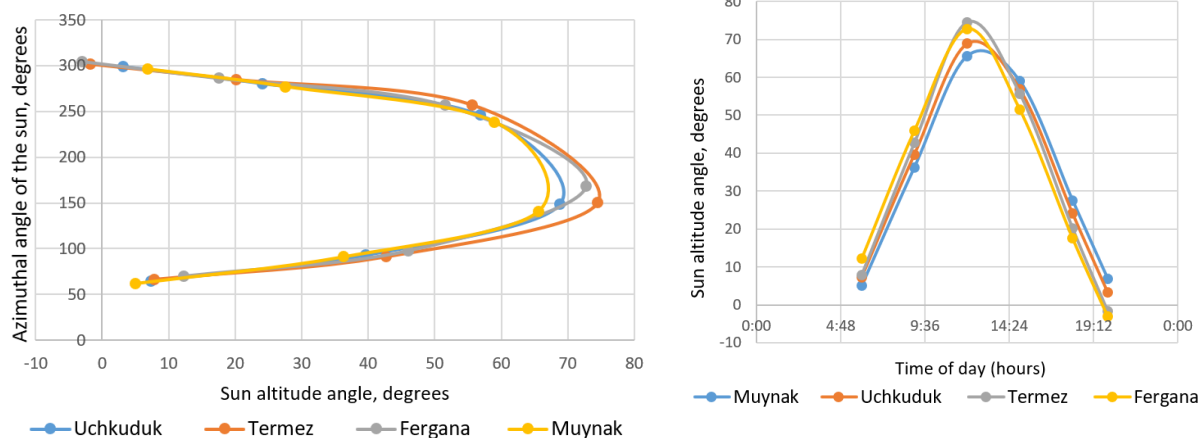

Figure 3. Diagram of azimuthal and altitude angles of the sun in the cities of Uzbekistan (a) and Diagram of the altitude angle of the sun by hour in the cities of Uzbekistan (b)

Table 2 and Figure 4 compare the azimuthal and altitude angles of the sun hourly in cities of Uzbekistan with similar latitudes. Obviously, the value of the altitude angle differs between cities mainly by hour. The city of Namangan is located in the east of Uzbekistan, which causes a significant increase in its value before noon in comparison with the

Kungrad region, located in the west of Uzbekistan, and at the same time, a decrease in the afternoon as sunset approaches. At noon we record the greatest difference in degrees of the azimuthal angle in the cities of Uzbekistan, which amounts to a maximum difference of 36 degrees between the Kungrad region and Namangan.

Table 2. Azimuthal and altitude angles of the sun by hour in cities of Uzbekistan with similar latitudes

Time of day (hours) June 21	Kungrad d-ct	Urgench	Chirchik	Namangan
		41.6203 deg N. 56.4280 deg E.	41.5345 deg N. 60.6248 deg E.	41.4689 deg N. 69.5822 deg E.
Sun altitude angle above the horizon, h (degrees)				
6:00	2.3255	5.0453	11.1306	12.4304
9:00	34.3664	37.504	44.1998	45.8193
12:00	65.8584	68.0654	71.3094	72.1533
15:00	61.7518	59.0515	52.8331	51.4429
18:00	29.2162	26.0943	19.5163	17.8759
20:00	7.7009	4.8407	-0.9899	-2.5581
Azimuthal angle of the sun, Az (degrees)				
6:00	60.235	62.9196	68.4608	69.6298
9:00	87.8791	90.5719	96.8325	97.9459
12:00	132.9547	141.0027	162.9209	168.5645
15:00	238.0294	243.641	253.3173	255.8169
18:00	276.4721	279.0798	284.473	285.8655
20:00	294.6291	297.2724	303.1031	304.4961

Figure 4. Diagram of the azimuthal and altitude angles of the sun for cities of Uzbekistan with similar latitudes (a) and Diagram of the altitude angle of the sun by hour for cities of Uzbekistan with similar latitudes (b)

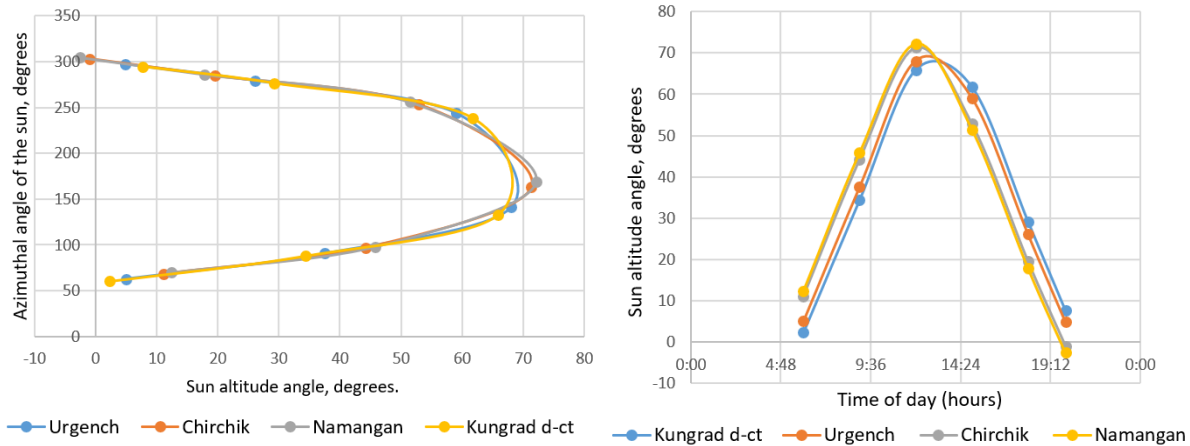

Table 3 presents the values of the azimuthal and altitude angles of the sun on characteristic days of the summer and winter solstices in Fergana. Figure 5 shows the solar altitude angle charts and the maximum and

minimum azimuthal angle ranges on June 21 and December 21 for use in the control algorithm of a dual-axis continuous tracking system.

Table 3. Azimuthal and altitude angles of the sun on the days of the summer and winter solstice in Fergana city

Fergana city, 40.3842 deg N. 71.7843 deg E.				
Time of day (hours)	Sun altitude angle above the horizon, h (degrees)		Azimuthal angle of the sun, Az (degrees)	
	June 21	December 21	June 21	December 21
6:00	12.2957	-16.9246	69.57	106.6784
9:00	45.9853	12.2475	97.4024	135.9718
11:00	66.8898	24.0682	131.5131	162.1458
12:00	72.7719	26.1251	168.5139	177.1689
13:00	70.5619	25.1698	212.7376	192.3951
15:00	51.5067	15.0636	256.6642	219.6725
17:00	28.7987	-2.5287	277.3699	240.9784
20:00	-2.9758	-35.2425	304.5468	267.7988

From the graphical dependencies presented in Fig. 5, it is clearly seen that at noon on June 21, the value of the altitude angle reaches a maximum value of 72.77°, while on December 21, the value of the altitude angle reaches a maximum value of 26.12°. The difference in degrees is 46.65.

On the day of the winter solstice, the duration of daylight at a latitude of 40.3842° is 9 hours at a maximum solar altitude angle of 26.1768°, while on the day of the summer

solstice the duration of daylight is more than 14 hours at a maximum solar altitude angle of 73.0439°. This proves the effectiveness of the use of tracking systems.

Discussions. A comparative analysis of the azimuthal and altitude angles is provided for cities in Uzbekistan located in radically different geographical coordinates, as well as in approximately the same northern latitudes, but at different eastern longitudes. In addition, a comparative characteristic of

the angle parameters and an assessment of the effectiveness of the use of solar tracking systems for a photovoltaic station for the

city of Fergana on the most characteristic days of the winter and summer solstice were carried out.

Figure 5. Diagram of the azimuthal and altitude angles of the sun on the days of the summer and winter solstice in Fergana (a) and Diagram of the altitude angle of the sun by hour on the days of the summer and winter solstice in Fergana (b)

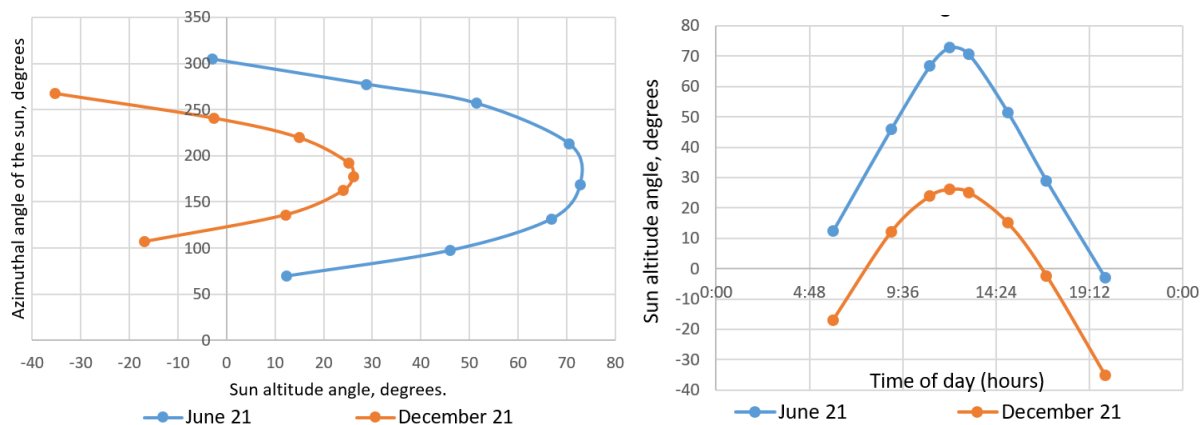

Conclusion. Carrying out an analysis of the change in the azimuthal angle on characteristic days of the year, we can conclude that the smallest difference is at noon and is 8.66° , but reaches a maximum in the hours of the day close to dawn and sunset and is

37.11° and 36.75° respectively. A dual-axis solar tracker allows to capture a wide range of angles of solar rays, which will provide a significant increase in the values of direct solar radiation arriving at the surface of photovoltaic modules.

References

- Ergashev, S.F., Tokhirov, M.K., Oshchepkova, E.A. “Selection of electrical and mechanical components for a sensorless solar parabolic system”. Universum, 2021.
- Reda, I. and Andreas, A. “Solar position algorithm for solar radiation applications”. Solar Energy, – Vol. 76(5). 2004. – P. 577–589.
- Mousazadeh, H., Keyhani, A., Javadi, A., Mobli, H., Abrinia, K. and Sharifi, A. “A review of principle and sun-tracking methods for maximizing solar systems output,” Renewable and Sustainable Energy Reviews, – Vol. 13. 2009. – No. 8. – P. 1800–1818.
- Saheli, R. “Calculation of sun position and tracking the path of sun for a particular geographical location,” International Journal of Emerging Technology and Advanced Engineering, – Vol. 2 (9). 2012. – P. 81–84.
- Mahmood, O. T. Programmable logic controller based design and implementation of multiple axes solar tracking system[C] // International Conference on Electrical, Communication, Computer, Power, and Control Engineering. IEEE, 2013: 101–106.
- Francisco, D., Pedro, D.G., Luis, C. G. Two axis solar tracker based on solar maps, controlled by a low-power microcontroller. Proceeding of the International Conference on Renewable Energies and Power Quality, Granda, Spain; 2010.
- Nayak, S.R. and Pradhan, C.R. “Solar Tracking Application”, in IOSR Journal of Engineering, 2012. – Vol. 2. – P. 1278–1281.

submitted 13.02.2024;

accepted for publication 23.02.2024;

published 18.03.2024

© Ergashev S. F., Oshepkova E. A.

Contact: Oshchepkova.elvira@gmail.com



DOI:10.29013/AJT-24-1.2-79-84



RESEARCH OF TECHNOLOGY FOR EXTRACTION OF COLORING SUBSTANCES FROM AMARANTH FLOWERS

*Saidkhodzhaeva Dildora Olimjon's daughter*¹,
*Choriev Abusattar Jo'rayevich*¹, *Usmonzhonova Khulkar Umarqulovna*¹,
*Akramova Rano Ramzitdinovna*¹, *Baltabaev Ulugbek Narbaevich*¹

¹ Tashkent State Technical University named after I. Karimov

Cite: *Saidkhodzhaeva D. O. daughter, Choriev A. J., Usmonzhonova Kh. U., Akramova R. R., Baltabaev U. N. (2024). Research of Technology for Extraction of Coloring Substances From Amaranth Flowers. Austrian Journal of Technical and Natural Sciences 2023, No 11-12. <https://doi.org/10.29013/AJT-24-1.2-79-84>*

Abstract

The article is devoted to the study of the technology for extracting dyes from amaranth flowers of the *Amaranthus tricolor* variety. The chemical composition of 2 varieties of amaranth was analyzed. The physicochemical parameters of the coloring matter were studied.

Keywords: *amaranth flowers, chemical composition, coloring matter, extraction, concentration, toxicological properties, organoleptic and physico-chemical indicators*

Introduction

The search for alternative ways to increase nutritional status, health levels, life expectancy, reduce morbidity among the population and mobilize the protective forces of the human body in a comprehensive solution to the problem of preserving the gene pool is relevant.

Due to the downward trend in the standard of living of the population in a number of countries, as well as a significant shortage of protein foods, there has been a need to develop and create, based on modern technologies, qualitatively new plant-based food products. Which would differ not only in their nutritional properties and storage stability, but also in their accessibility to all segments of the population.

A priority direction of science is also the improvement of technology for enriching

food products with macro and micro nutrients obtained through complex processing and production of products from non-traditional sources of raw materials.

Literature Review

Finding new plant sources of food protein, biologically active additives, as well as developing technology for their processing to obtain products of increased biological and nutritional value with a functional focus is one of the urgent tasks of the baking industry.

Many experts consider amaranth to be one of the most promising plants for universal purposes. This plant is native to South America. Its unique properties have been confirmed by modern researchers. Amaranth is intensively cultivated in the mountainous regions of Nepal, India, Mexico and Peru.

Recently, amaranth plantations have increased in China, Africa, the USA, and Canada. In these countries, both amaranth grain and its leaf mass are used.

Amaranth is superior to traditional crops in terms of nutrient content, especially protein and fat (Zelenkov, V.N., 2000). In Russia, over 150,000 people are employed under amaranth, but they use it mainly for feed needs. For a comprehensive study of amaranth, research centers have been organized in the USA, Mexico and a number of other Latin American countries, where attention is paid to selection and genetic work and the collection of hormone plasma from local species and species introduced from other regions. More than 1,000 forks have been collected at the Rodhals Research Center (USA) alone. Using modern selection methods, new varieties of amaranth have been created in the USA, Ecuador, Argentina, and Mexico.

Five species of amaranth are believed to be of American origin. Another type of amaranth of Asian origin is cultivated in America (Kononkov, P.F., 1997).

In our country, the need to use amaranth in agriculture as a new food and silage crop in the program for the use of world plant resources was pointed out by Academician N.I. Vavilov back in 1932. However, research work with amaranth and other new crops, begun on his initiative, was stopped after his death. And only in recent years have amaranth been intensively introduced into agriculture in neighboring countries.

The chemical composition of useful substances in amaranth is given in Table 1. (Saidkhodzhaeva, D.O., Choriev, A.ZH. 2023; Saidkhodzhaeva, D., Choriyeu, A., Akramova, R., Yulchiev, A., Tukhtaev, Sh. 2023; Saidkhodzhaeva, D., Choriyeu, A. 2022).

Table 1. *Chemical composition of useful substances in amaranth, g/100g*

Name	Proteins, g	Carbohydrates, g	Fats, g	Cellulose, g	Calorie content, kkal
Amaranth	14	70	7	7	370

From this table 1, we can say that the amount of carbohydrates is the most, which is 79 g/100g.

Methods

The assessment of the chemical composition of dyes was carried out using physical and chemical methods.

Results And Discussion

Natural dyes (NDCs) are complex organic compounds produced by living organisms and color various cells and tissues of animals and plants. Most PVCs have significant physiological and antibiotic activity. They are often used as medicinal products. The increase in allergic and cancer diseases caused by environmental pollution has led to the need to expand the production of harmless natural food dyes.

The production of natural dyes currently does not meet the needs of the market, either in quantity or range. This problem is solved partly through synthetic dyes. Therefore, improving the existing technology of natural dyes is an important task of our time.

Food dyes are subject to strict requirements in terms of their harmlessness, lack of interaction with components of food formulations, color strength, high degree of coloring at low concentrations of dye, ability to dissolve in water or fat, as well as uniform distribution in the mass of food products, absence of foreign tastes and smells.

Over 2000 different plants containing dyes are known, but only a few of them have found practical use, mostly belonging to the legume, asteraceae, mulberry, and madder families.

It is known that the degree of extraction of coloring matter from plant raw materials depends on many factors: its biochemical composition, degree of grinding, nature of the extractant and extraction conditions. There are various known methods for obtaining anthocyanin dyes from plant raw materials, which consists in processing plant raw materials, which are used as chokeberry pomace (RF patent No. 2008314), beets (RF patent No. 2081136), grape waste (US patent No.

3963700), carrots (patent US No. 4939086) blueberries, black currants and other berries (Czech Patent No. 292834), red potato juice (US Patent No. 6180154), rose petals or crushed red cabbage, aqueous solutions of acid and/or alcohol, extract separation, concentration and receiving the finished product. From sunflower, by processing with solutions of organic acids, extract separation and concentration, a red natural anthocyanin dye, resistant to light and temperatures, is obtained, which is successfully used in the food, cosmetic and pharmaceutical industries (US patent No. 6132791).

There is also a known method for producing anthocyanin dye from waste food raw materials, for example cherries, plums, grapes, in which from the primary hydrochloric acid extract, after neutralization, the coloring substances are precipitated with slaked lime, after which the precipitate is pressed off and dissolved with concentrated hydrochloric acid (USSR author's certificate No. 218358).

There is a known method for producing anthocyanin food coloring from dried chokeberry pomace by crushing the raw material, treating it with acetaldehyde containing 0.5–10 parts by weight. concentrated orthophosphoric acid from the reaction medium, filtration, drying and extraction of dyes with heated ethyl alcohol acidified with butyric acid, and separation of the organic layer from the raw material (RF patent No. 2099371).

Anthocyanin dye from plant raw materials is known, containing cyanidin glycosides, pinonidin glycosides, pelargonidin glycosides, organic substances and mineral salts at a certain ratio of components (RF patent No. 2177015). This food coloring retains its natural red color when exposed to a pH environment from 2.0 to 7.0, with all treatments: freezing, boiling, irradiation with direct sunlight.

There is a known method for producing a pigment additive from plant raw materials (parsley). Dried parsley is crushed, then extracted under countercurrent conditions with 96% alcohol at a raw material to extractant ratio of 1:2–1:4 for no more than 40 minutes in the presence of MgCO₃ or MgO, or their mix-

ture 0.1–1.0% on the amount of raw materials at 10–22 °C. The extract is filtered, collected in a common container, the solvent is distilled off and concentrated at a temperature not exceeding 40 °C and a residual pressure of not more than 1333 Pa for 1 hour. Dry until the dry matter content is 78–80% (RF patent No. 2154075).

There is a known method for producing green food dye from carrot tops by extracting the raw material with an organic solvent, saponification with alkali, acidification, stabilizing the dye, converting it into a water-soluble form and subsequent drying (author St. 266117, C09 V 61/00, USSR No. 1307201/28–13).

However, the disadvantages of the known methods are the use of non-food chemicals in the technological chain, which makes the further use of the dye not harmless, as well as the unreasonable labor intensity of the technological process.

Dying substances are usually isolated from various parts of plants, the color of which is due to the presence of anthocyanins, carotenoids, flavonoids, chlorophylls, etc.

The quality of natural dyes largely depends on the conditions in which the plants developed (climate, soil, etc.). It is also influenced by the technology of extracting dye from raw materials. Currently, technological methods for isolating natural food dyes are increasingly being improved. The raw materials are pre-frozen, dried, and treated with steam. The latest technologies, in particular membranes, are used to extract dyes. An increase in the yield of dyes can also be achieved by treating plant tissues with hydrolytic enzyme preparations.

There is also a known method for producing a paste-like food coloring from beet pomace: after separating the juice, the pomace is extracted with water at a temperature of 70–80 °C, then the resulting extract and beet juice are mixed and the resulting mixture is filtered, a stabilizer is introduced into the resulting mixture, followed by instant heating to 80 °C and cooling to 30 °C, yeast is introduced into the cooled juice in an amount of 0.1% and fermented, after which condensation is carried out at a temperature not exceeding 60 °C (RF patent No. 2031100). There is also a known method for producing powdered food coloring from beets by grinding, pressing, stabilizing the juice with ascorbic acid, pasteurization, cooling to a temperature of 20–22 °C, adding baker's yeast *Saccharomyces cerevisiae* in an amount of 0.03–0.07% by weight of the juice, fermentation, filtration and drying on inert media (RF patent No. 2102418).

The disadvantages of the known methods are: low quality of products, low thermal stability, imperfection of the technological process.

Based on a patent search and a literature review, we proposed a technological scheme for the extraction of dyes from amaranth flowers (Fig. 1).

Taking into account the classification of natural dyes into flavonoids, betalains, quinones, chalcones and oxycetones, carotenoids, riboflavins, indigoids, porphyrins, taking into account their formation in the flower, fruit, leaf, body, bark, root, it is possible to form a single processing line with minor differences for one or another raw materials (Kacerikova, I. V., 1999).

Figure 1. *Technological line for extracting dyes from amaranth flowers*

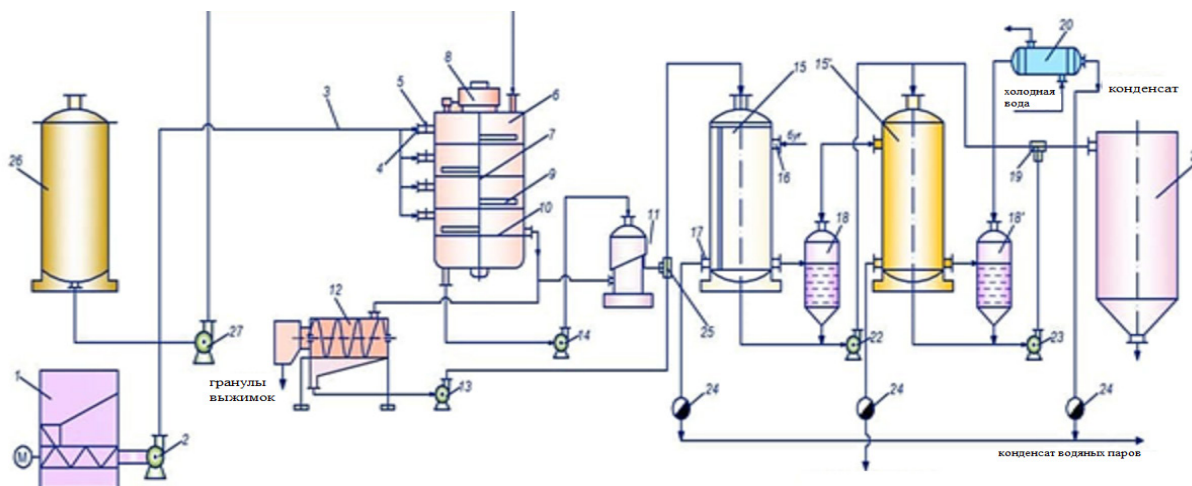

1. Hopper for uniform supply of raw materials. 2. Pneumatic conveyor pump.
3. Pneumatic transport. 4. Entrance on the upper tier. 5. Gate 6. Extractor 7. Shaft. 8. Drive. 9. Mixer cam. 10. Dividing mesh. 11. Centrifuge. 12. Press granulator. 13, 14, 22, 23. Pumps. 15, 15'. Evaporator housing. 16. Heating steam inlet fitting. 17. Condensate outlet fitting. 18, 18'. Evaporator separator. 19. Refractometer. 20. Capacitor. 21. Tank for collecting condensate. 24. Condensate traps. 25. Tee. 26. Extractant storage tank

The extract is obtained directly from the raw material; it also contains solid particles. The components of the substrate consist of soluble and insoluble fractions; insoluble components are separated under the influence of gravity in settling tanks and filters, in the field of centrifugal forces. To do this, the extract in containers is subjected to sedimentation, centrifugation or separation using a separator. If necessary, the fabric is cleaned using a filter; a purer fraction is obtained us-

ing paper filters, and the purest fraction is obtained using ultrafilters.

According to the chemical composition, the extract is concentrated in a vacuum evaporator (VVE) after the degree of purity meets the parameters of the technological regulations. The technology has been improved through the use of vacuum evaporation of the extract in 2-hull complexes; the plant has its own extractant, so more than 2 tanks are used to store the extractant (Usmonzhonova, H.U. 2021).

Table 1. Results of the analysis of the toxic properties of coloring substances extracted from the flowers of the amaranth variety *Amaranthus tricolor*

No	Dose, mg/kg	Number of dead animals / total
1.	5000	0/6
2.	10000	0/6
3.	15000	0/6

$LD_{50} > 15000 \text{ mg/kg}$

In the Pharmacy-Innovation center located in the Yunusabad district of Tashkent, the toxicological properties of a concentrate of coloring substances extracted from the flowers of the amaranth plant were studied. *Amaranthus tricolor*.

The organoleptic characteristics of the dye concentrate obtained from the *Amaranthus tricolor* variety were studied. The color of the resulting dye turned out to be transparent red, without any foreign odors or tastes (Table 3).

Table 3. Organoleptic characteristics of a concentrate of coloring substances obtained from amaranth plants

Plant name	Color	Consistency	Smell	Taste
------------	-------	-------------	-------	-------

Amaranth plant (<i>Amaranthus tricolor</i>)	Transpar- ent dark red	Fluid	No foreign odors	The unique taste of ama- ranth has been partially preserved
--	---------------------------	-------	---------------------	---

The physicochemical parameters of the concentrate of coloring substances obtained from amaranth plants were studied (Table 4.)

Table 4. *Physico-chemical indicators of a concentrate of coloring substances obtained from amaranth plants*

Plant name	Relative density, g/l	Number of substances contained,%	Index, pH	The amount of coloring matter in the spectrum 540 nm, g/l
<i>Amaranthus tricolor</i> L.	1.000	9.4	4.4	4.3

Conclusion

A technology for extracting dyes from amaranth flowers has been proposed.

The toxicological properties of a concentrate of coloring substances extracted from the flowers of the amaranth plant *Amaranthus tricolor* were studied. The analysis results showed that it is suitable for use in the food industry.

The organoleptic characteristics of the dye concentrate obtained from the flowers of the amaranth variety *Amaranthus tricolor*, which complies with the standard, have been studied.

The physicochemical parameters of the dye concentrate were studied.

References

- Zelenkov, V.N. Himicheskij i mineral'nyj sostav razlichnyh chastej amaranta / V.N. Zelenkov, N. P. Zaksas// Mater. 3-yj Mezhdunarodnoj nauch.-proizvod. konf. "Introdukcija netracionnyh i redkih sel'skohozyajstvennyh rastenij". – Penza. 2000. – P. 18–19.
- Kononkov, P.F. Amarant – perspektivnaya kul'tura XXI veka / P.F. Kononkov, V.K. Gips, M. S. Gins.– M.: Izd-vo RUDN, 1997.– 160 p.
- Saidhodzhaeva, D. O., Choriev, A. ZH. Issledovanie himicheskogo sostava ekstraktov, poluchennyh iz list'ev amaranty.– Nauchnyj zhurnal Vestnik Kazahskogo universiteta tekhnologii i biznesa.– № 4. 2023.– P. 73–78. URL: <https://doi.org/10.58805/kazutb.v.4.21–200>.
- Saidkhodzhaeva, D., Choriyev, A., Akramova, R., Yulchiev, A., Tukhtaev, Sh. Study of the chemical composition of the amaranth plant by the method of chromatography // E3S Web of Conferences – 390. 2023.– 04039 p. URL: <https://doi.org/10.1051/e3s-conf/202339004039>. AGRITECH-VIII 2023.
- Saidkhodzhaeva, D., Choriyev, A. Izuchenie himicheskogo sostava rasteniya amarant Vestnik nacional'nogo universiteta Uzbekistana. 2022.– 3/1/1,– P. 398–400.
- Kacerikova, I. V. Prirodnye pishchevye krasiteli: Obzornaya informaciya / N.V. Kacerikova, V.M. Poznyakovskij.– Novosibirsk: EKOR, 1999.– 58 p.
- Usmonzhonova, H. U. Sovershenstvovanie tekhnologii polucheniya natural'nyh pishchevnyh krasitelej iz rastitel'nogo syr'ya. Avtoreferat dissertacii doktora filosofii (PhD) po tekhnicheskim naukam.– Tashkent, 2021.– 44 p.

submitted 15.01.2024;

accepted for publication 30.01.2024;

published 18.03.2024

© Saidkhodzhaeva D. O. daughter, Choriev A. J., Usmonzhonova Kh. U., Akramova R. R., Baltabaev U. N.

Contact: corievabdusattor@gmail.com



DOI:10.29013/AJT-24-1.2-85-89



SELECTION OF A METHOD FOR PREPARING NATURAL GAS FOR TRANSPORTATION BY MAIN GAS PIPELINES

*Makhmudov Mukhtor Dzhamolovich*¹, *Yomgirov Sa'dulla Ataboy u gli*¹

¹ Bukhara Institute of Engineering and Technology Bukhara, Uzbekistan

Cite: *Makhmudov M.D., Yomgirov S.A. (2024). Selection Of A Method For Preparing Natural Gas For Transportation By Main Gas Pipelines. Austrian Journal of Technical and Natural Sciences 2023, No 11-12. <https://doi.org/10.29013/AJT-24-1.2-85-89>*

Abstract

When designing natural gas drying equipment, the ability to implement an integrated approach to determine rational technical and economic indicators of the technological devices under consideration is of great importance. This makes it possible to achieve maximum energy efficiency from the equipment in use for each specific field.

One of the important tasks solved during the development of gas fields is the choice of method and appropriate technological equipment according to many criteria, including operating costs and cost of devices, installation productivity, metal consumption, replicability of the technology in question, etc. One of the ways to solve such a problem is to use mathematical methods of system analysis in complex decision-making problems, in particular, the method of hierarchy analysis.

Keywords: *natural gas dehydration, absorption, low-temperature separation, membranes, hierarchy analysis method*

Introduction

In terms of its physical and chemical characteristics, the prepared combustible natural gas (FNG) must comply with the criteria and standards of STO Gazprom 089–2010 “Flammable natural gas supplied and transported through main gas pipelines. Technical specifications” (Shimekit, B., Mukhtar, H. et al. 2009).

In accordance with STO Gazprom 089–2010 of a cold macroclimatic region, the water dew point temperature at an absolute pressure of 3.92 MPa (40.0 kgf/cm²) should not be higher than: in winter – minus 20 °C; in summer – minus 14 °C, which is required

for strict compliance with the conditions of its single-phase transportation in all sections of the main pipeline. Also, for a cold macroclimatic region, the dew point temperature for hydrocarbons at an absolute pressure of 2.5 to 7.5 MPa should not be higher: in winter – minus 10 °C; in summer – minus 5 °C.

The dryable gas is gas that has undergone preliminary cleaning from mechanical impurities and droplets of moisture in the gas separation shop of an integrated gas treatment plant, as well as an increase in pressure at the booster compressor station. The residual content of droplet moisture and mechanical impurities in the purified gas is determined

by the requirements for the technical characteristics of separation equipment and should not exceed: droplet moisture — 20 mg/m³ of gas; mechanical impurities with particle sizes of no more than 20 microns — 5 mg/m³ of gas (Makhmudov, M. J., Emgurov, S. A., 2023).

The gas industry knows a sufficient number of different types of natural gas drying, which provide solutions to local problems of deep extraction of droplet moisture from a raw gas flow, but do not solve the problem as a whole, these include: absorption gas drying, gas drying by low-temperature separation, low-temperature absorption drying gas, adsorption gas drying, gas drying using membrane technology. Each of the methods has both its advantages and disadvantages, which generally determine the main technical and economic indicators (Shimekit, B., Mukhtar, H. et al. 2011; Makhmudov, M. J., Emgurov, S. A., 2023). Which method to choose is one of the most important tasks in making pre-project decisions and, despite the fact that it is determined by the total maximum positive effect with minimal economic requirements, it is not always obvious and is often a compromise decision.

A mathematical solution to the presented problem can be achieved through the use of systems analysis methods and, in particular, the method of hierarchy analysis. The main methods of gas drying we will consider the features of the main technological methods of drying natural gas.

Absorption gas drying

A typical scheme for drying gas with glycol is based on contact of dry glycol with raw gas and absorption of moisture from the latter at feed temperatures from + 10 to + 35 ° C. Raw gas, previously separated, enters the absorption column from the bottom up. From the top of the column, through the distribution section, 98–99% glycol is supplied in a countercurrent direction to the gas movement. Thanks to the mass transfer section of the absorption column, maximum contact of gas with glycol is ensured, thereby causing the process of glycol gas dehydration. The dried gas enters the upper part of the column, passes through the glycol recovery section and is supplied to consumers. The moisture-saturated glycol flows by

gravity from the bottom of the column to the regeneration unit.

Gas drying by low temperature separation

The essence of low-temperature separation is pre-cooling the gas to subzero temperatures, followed by separation of the condensed droplet liquid in a low-temperature separator. The raw gas from the wells, under its own pressure, enters the first stage gas separator, where the primary separation of the dropping liquid, the resulting condensate and mechanical impurities takes place, which are sent to the drainage tank. Next, the gas, freed from the droplet liquid, enters the gas-gas heat exchanger for pre-cooling with the reverse flow of gas coming from the second stage separator (low-temperature separator). To prevent the formation of hydrates, a hydrate formation inhibitor (methanol, diethylene glycol) is supplied to the gas before the heat exchanger. Next, the gas is throttled by the valve, being cooled due to the Joule-Thomson effect to the required negative temperatures. The cooled gas is supplied to the second stage gas separator, where the condensate with a water-saturated inhibitor solution is separated from the gas. The dried gas is heated by raw gas by feeding it to the above-mentioned gas-to-gas heat exchanger and sent to the commercial gas metering unit.

Low temperature absorption gas dehydration

In essence, the technological scheme of low-temperature absorption gas drying is a combination of the two methods of natural gas drying described above, but is a more technologically complex system. Raw gas under pressure enters the first stage gas separator. Next, the gas, with a small content of droplet liquid, enters the gas-liquid heat exchanger for pre-cooling by the reverse flow of the absorbent coming from the low-temperature absorber, which is a multifunctional apparatus that combines both a separation section (the lower part of the column) and an absorption section (top of the column). The pre-cooled gas enters the subsequent gas-to-gas heat exchanger, in which it is further cooled by the reverse flow of dried gas supplied from the low-temperature absorber.

To prevent the formation of hydrate plugs, a hydrate formation inhibitor is supplied to the gas before each heat exchanger. Next, the gas, which has passed through two successive heat exchangers, is throttled by a valve to the required negative temperatures and sequentially, through the separation section, is fed into the absorption section of a low-temperature absorber for deep extraction of condensed moisture. The gas dried in the low-temperature absorber is, in turn, heated by raw gas in the above-mentioned gas-to-gas recuperative heat exchanger and sent to the main gas pipeline.

The system uses gas condensate separated in the first-stage separator as an absorbent, which, before being fed into a low-temperature absorber, is sent for degassing and subsequent cooling with a cold stream of absorbent from the low-temperature absorber in a liquid-liquid heat exchanger.

Adsorption gas drying

The adsorption scheme for gas drying is similar in structure to the absorption scheme, with the only exception that an adsorbent (silica gel, zeolite) is used as a desiccant. The raw gas, separated from droplet moisture and mechanical impurities, enters an adsorption column filled with a composite water vapor adsorbent in the direction from top to bottom. The gas leaving the adsorber is dried and meets all the requirements for its transportation through main gas pipelines. As soon as the gas drying depth begins to decrease, the feed gas flow is switched to the adsorber that was in the standby stage to ensure continuity of drying, and the adsorber with saturated adsorbent is switched to regeneration. Since the adsorbent, unlike the absorbent, does not circulate through a closed gas drying system and is constantly located in the adsorber, built-in heat exchange elements of a spiral-radial type are provided in the adsorbers for its regeneration.

Gas drying using membrane technology. The method of separating natural gas from hydrocarbon raw materials that meets the requirements of the standard for its preparation using membrane technology is based on the difference in the partial pressures of the components on the outer and inner surfaces of the hollow fiber membrane. Gases that

“quickly” penetrate the polymer membrane exit through the membrane cartridge structure through the retentate outlet (purified gas). Gases and liquids that «slowly» or do not penetrate the membrane layer exit the unit through the permeate outlet. Thanks to the selective properties of the separating layer of membranes, so-called “slow” components, such as moisture, heavy hydrocarbons, mercaptans, sulfur compounds and carbon dioxide, are extracted from the gas that has undergone preliminary separation. And “fast” prepared natural gas, with a slight loss of pressure at the installation, is supplied to the main gas pipeline.

The membrane element is a non-regenerable component of the gas treatment system, which requires replacement if the requirements for gas treatment specified in the technological regulations for the operation of the installation are not met.

Approbation of the method. The basis of the hierarchy analysis method is the hierarchical representation and pairwise comparison of the main technical and economic indicators of natural gas preparation methods (Sridhar, S., Smitha, B., et al. 2007; Murin и другие. 2002). The result is the creation of an appropriate matrix, which is based on a six-point scale with the comprehensive advantages of each criterion from the compared methods. At each stage of comparison, the independence of the indicators under consideration must be achieved, which must have clear differences from each other (Makhmudov, M.J., Akhmedov, U.K. 2020; Makhmudov, M.J., 2020).

As a result, a rational method for drying natural gas is determined with the best technical and economic indicators for each specific case, which allows you to interactively find an option that best matches the requirements for solving the problem and ultimately contributes to its solution, while preventing unjustified economic expenses. The proposed method is tested for five methods of drying natural gas: absorption drying, low-temperature separation, low-temperature absorption, adsorption and drying using membrane technologies.

In modern conditions in which power engineering is developing, the key factor influencing the prevalence of technologies

is their cost. The lower the costs of their implementation, the more accessible they are, and the more accessible the technologies, the more researched they are and, accordingly, have undergone more changes in order to optimize them. More advanced technologies do not require high operating costs and have high efficiency along with productivity. The operating costs indicator is inversely proportional to the reliability parameter, because the more perfect the system, the less resources it requires for maintenance. In addition, for hard-to-reach operating areas, an important criterion for the use of technology is its metal consumption, because the more mobile the system, the less costs are required for its transportation and installation. As a rule, the more innovative the system, the lower its metal consumption, but the higher its cost.

Based on the above, the analysis of natural gas drying systems was carried out according to six selection criteria: cost (A) – potential costs (in financial terms) for the implementation of the selected technology; efficiency (B) – the ability to achieve the required in accordance with STO Gazprom 089–2010 “Combustible natural gas supplied and transported through main gas pipelines” under changing thermobaric operating conditions; probability (C) – prevalence, knowledge, reliability and possibility of application in the field; metal intensity (D) – the amount of metal consumed for the manufacture of a natural gas drying installation; operating costs (E) – a general indicator of the costs incurred by the organization to ensure the operation of

the natural gas drying plant; productivity (F) – the amount of gas prepared by a gas drying installation to the required values over a certain period of time.

Conclusion

Calculations based on the hierarchy analysis method and subsequent analysis of the information obtained clearly indicate that, according to the technical and economic characteristics presented in the work, despite the high metal consumption of the structure and average efficiency indicators, absorption dehydration of natural gas is the most preferable method over the methods discussed in the article natural gas treatment (significance factor 0.361). The key calculation criterion for selection when determining the method was the probability criterion of the technology used; its significance was 55.9%.

The justifiably chosen method of absorption drying of natural gas makes it possible to achieve the required preparation of raw materials with relatively low operating costs and insignificant pressure losses of the drying gas. This method is high-tech and energy efficient, since the glycol used in drying and saturated with moisture vapor, having gone through a closed cycle of purification and regeneration, after restoring its commercial qualities, is again supplied to the absorption equipment. In addition, the positive characteristics of this method include its high productivity in the context of one production line and time-tested reliability.

References

- Shimekit, B., Mukhtar, H. et al. (2009). Ceramic membranes for the separation of carbon dioxide: A review. *Transaction of Indian Ceramic Society*, – Vol. 68. – No. 3. – P. 115–138.
- Махмудов, М.Ж., Ёмгуров, С.А. Адсорбционные способы очистки, осушки и отбензинивания природных ГАЗОВ // *Наука и инновация*. 2023. – Т. 1. – № . 5. – С. 95–96.
- Shimekit, B., Mukhtar, H. et al. (2011). Prediction of the relative permeability of gases in mixed matrix membranes. *Journal of Membrane Science*, – Vol. 373. – No. 1–2. – P. 152–159.
- Махмудов М.Ж., Ёмгуров, С.А. Низкотемпературная сепарация природного газа // *Наука и инновация*. 2023. – Т. 1. – № . 5. – С. 97–98.
- Sridhar, S., Smitha, B., et al. (2007). Separation of carbon dioxide from natural gas mixtures through polymeric membranes-a review. *Separation & Purification Reviews*, – Vol. 36. – No. 2. – P. 113–174.
- Мурин и другие. Переработки природного газа и конденсата: Т 38 Справочник: В 2 ч. – М.: ООО “Недра-Бизнесцентр”, 2002. – Ч. 1. – 517 с.

Makhmudov, M. J., Akhmedov, U. K. Colloidal-chemical features of surfactants and additives into low octane gasolines to improve their quality // International Scientific Review. 2020.— № . 1.— P. 6–10.

Махмудов, М. Ж. Определение адсорбционной ёмкости синтетического цеолита NaX в динамических условиях по ароматическим углеводородам низкооктанового бензина // Нефтепереработка и нефтехимия. Научно-технические достижения и передовой опыт. 2020.— № . 7.— С. 13–16.

submitted 10.02.2024;
accepted for publication 22.02.2024;
published 18.03.2024
© Makhmudov M. D., Yomgirov S. A.
Contact: makhmudov.mukhtor@inbox.ru



DOI:10.29013/AJT-24-1.2-90-93



DEVELOPMENT OF EFFECTIVE LUBRICANTS FOR DRILLING FLUIDS

Kobilov Nodirbek Sobirovich¹

¹Institute of General and Inorganic chemistry of Academy of sciences
of the Republic of Uzbekistan, Tashkent, Uzbekistan

Cite: Kobilov N.S. (2024). *Development of Effective Lubricants For Drilling Fluids*. *Austrian Journal of Technical and Natural Sciences* 2023, No 11-12. <https://doi.org/10.29013/AJT-24-1.2-90-93>

Abstract

The paper shows the role of lubricants for obtaining drilling fluids. Methods of testing lubricant's chemical and physical properties. New compositions of lubricants for water based drilling fluids. Stabilization and antifriction indexes of drilling fluids based on lubricants have been given.

Keywords: *lubricant, property, viscosity, friction, drilling fluids, oil an gas*

Introduction

Importance of the use of lubricating additives — lubricants in drilling fluids and process of fluids occupy a particularly important place in the technical, technological, economic and environmental indicators of the success of the construction of oil and gas wells. The technology for drilling any wells consists of destroying rocks at the bottom with a chisel and removing destruction products from the bottom to the surface by forced circulation of the drilling fluid in the well. The main technical functions of the drilling fluids are to clean the bottom and wellbore from drilled rock, to create back pressure above the formation pressure in order to prevent the uncontrolled influx of formation fluid. Therefore drilling fluid must ensure lubrication and cooling of the drilling tool, stabilization of the walls of the open wellbore and maximum preservation of reservoir properties of the productive formation during initial drilling (Bulatov, A.I., 1984).

For drilling wells of drill cuttings during the drilling process, in most cases, water-based emulsion (WBO) is used; less often, direct or reverse hydrocarbon-based emulsion (HBO) is used. Modern water based mud (WBM) and oil based mud (OBM) are complex multifunctional poly disperse systems, the physicochemical and technological properties of which are regulated by a complex of chemical reagents: regulators of viscosity and thixotropic structure of the solution, filtration (water loss) reducers, lubricating and anti-seizing additives, clay inhibitors, bridging agents, defoamers, weighting agents and other additives. (Chubik, P.S., 1999).

Managing the technological parameters of a drilling fluids is the task of managing a complex non-traditional chemical-technological dispersed system, constantly changing in mineralogy. Technical and technological reasons for the use of lubricating additives in drilling fluids. During the construction of

oil and gas wells, great importance is given to reducing energy intensity and accident rate of the drilling process through the use of drilling drills with improved tribotechnical (lubricating, anti-seizing, anti-wear) properties. Particularly serious problems arise associated with frictional forces and the increase in torque during rotation, with loads when lifting the drill string when drilling directional and horizontal wells, as well as when drilling sidetracks of small diameter with large deviations from the vertical. It is under such conditions that the use of BR with increased lubricity gives the most noticeable positive effect. Improvement in tribotechnical properties depends on the chemical nature of the organic base of the lubricant additive and its concentration in the drilling fluids, on the physicochemical ability to reduce the coefficient of friction in a multi disperse medium enriched with drilled solid mineral phase. Reducing the drilling fluids friction coefficient during drilling allows:

- reduce hydraulic resistance when flushing the wellbore;
- reduce the torque when rotating the drill string and reduce the resistance when it longitudinally moves in the well;
- reduce the likelihood of differential sticking and the costs of their elimination;
- increase the service life of drill pipes and their connections, hydraulic parts of mud pumps, downhole motors and rock cutting tools.

As indicators of tribological properties, they usually use the coefficient of friction of a metal-to-metal pair in the drilling fluids environment, the coefficient of potential differential sticking of the drill pipe – borehole wall system, as well as the coefficients of friction and stickiness (friction) at the boundary “metal-clay cake” (Chubik, P.S, 1999, Samota, A. K, 1979).

Materials and methods

As a material for obtaining new lubricant composition were used Gossypol resin (GR), Sodium, Carboxymethylcellulose sodium (CMC), Used motor oil (UO), Soap stock (SS) and Oil sludge (OS). Gossypol resin is obtained in the form of a distillation residue (tar) by distillation of fatty acids from cotton soap stock. In order to protect the health of

citizens and protect the natural environment, this technological regulation has been established. In the oil and fat plant, before obtaining gossypol resin, products are obtained in the following order: – “inedible fat and oil products” – fat and oil products intended for technical and household purposes; – “soap stock” – a by-product obtained during alkaline neutralization of fats and oils; – “tar” – non-distilled vat residue; – “gossypol resin” – tar from the distillation of fatty acids of cotton soap stock.

CMC and Oil sludge are also used for obtaining lubricants as stabilizer of a solution (Kobilov, N.S. and other, 2023). Used motor oil. Used motor oil often contains metals (usually as the result of the engine or bearing wear, or the inclusion of these metals in oil additives), chlorinated hydrocarbons and other organic compounds, including a lot of that are listed as priority pollutants.

Determination of physical and chemical properties of drilling fluids

- Determination of the coefficient of friction of the filter cake of drilling fluid in field laboratories and on drilling rigs in order to identify the effectiveness of lubricant additives and prompt intervention in the drilling process in difficult conditions in the fields of the Republic of Uzbekistan, the KTK-2 device is widely used. The coefficient of friction (stickiness) at the “clay cake – metal” boundary is measured by the angle at which a standard load begins to slide over the filter cake, followed by determination of the coefficient value in the table attached to the KTK-2 device
- **Determination of Mud Density.** The weight of the mud samples was determined using the Baroid mud balance. The cup was filled completely with mud after calibration. The expelled mud was washed and the balanced arm was replaced on the base with the knife edge resting on the fulcrum. The rider was moved until the graduated arm was horizontal and the reading was taken.
- Viscosity is usually higher for higher density fluids due to the weight of the material. Here, the Marsh fun-

nel is used to monitor viscosity and is commonly reported as “Funnel viscosity”. The Marsh funnel viscosity is reported as the number of seconds required for a given fluid to flow out of the funnel. Its design and calibration can be verified using water. One quart of fresh water should be collected in 26 (± 0.5) sec at a temperature of 70 (± 5) °F. The marsh funnel measures the apparent viscosity.

- **Determination of Fluid loss and mud cake thickness.** The filter press (100 psi pressure and room temperature) was used to measure the fluid loss and mud cake thickness of the drilling fluid samples after 30 min.
- used to determine the gel strength of the mud samples. The mud samples were stirred thoroughly at 600 rpm. The lift gear was shifted slowly to the first position, and the motor was shut off. The motor switch was turned to low after 10 seconds. The dial was read at maximum deflection units in Ib/100ft² that is 10 second gel. The steps were repeated for 10 minutes. The Gel strength was obtained for the different mud weights.
- **Determination of pH.** The pH meter which consists of a glass electrode system, an electronic amplifier and a meter calibrated in pH units was used to test the pH of galena mud. The electrical connection with the mud was established through saturated KCl solution contained in a tube surrounding the calomel cell. The electrical potential generated in the glass – electrode system by the hydrogen ions in the drilling mud was amplified and operated the calibrated meter which indicated the pH. The pH of the mud was noted.
- **Determination of stability and sedimentation indicators.**
- Stability – the ability of a solution to its density over a period of time. The stability index S_0 is a value determined by the difference in densities of the lower and upper parts of the drilling mud settled for a certain time.
- Sedimentation index $S, \%$, is the value determined by the amount of the

dispersed phase, separated from a certain volume of the drilling fluid as a result of gravitational separation of its components for a certain time. The sedimentation rate indirectly characterizes the stability of the drilling fluid (Kobilov N.S, 2023).

Therefore determination of the filtration index and the coefficient of friction of the filter cake of drilling fluid in field laboratories and on drilling rigs in order to identify the effectiveness of lubricant additives and prompt intervention in the drilling process in difficult conditions in the fields of the Republic of Uzbekistan, the KTK-2 device is widely used. The coefficient of friction (stickiness) at the “clay cake – metal” boundary is measured by the angle at which a standard load begins to slide over the filter cake, followed by determination of the coefficient value in the table attached to the KTK-2 device.

Results and discussion

Application of oil and petroleum products in drilling fluids.

For development lubricant additives were used following compositions of gossypol resin (GR), soap stock (SS), soda caustic, used motor oil (UMO), oil sludge (OS), carboxymethyl cellulose (CMC) and water (W). The first stage of obtaining lubricants were used modified gossypol resin with sodium (MGR). Next process of obtaining its water solution about 20–30% with CMC and about 10–20% of UMO or OS. The results of the testing were given in the table 1.

Laboratory testing shows that examples of lubricants have high antifriction properties coefficient of friction of N^o 1 is equal 0,1228, viscosity is 28 filtration index is more than 3 sm³. Less density is in the N^o 3 example because of in the composition there is soap stock. Soap stock is consist of more stearin acid comparing to other compositions. Water solution of stearin acid appears penetration process. Modified gossypol resin play role as a emulsifier and used motor oil emulsion formed in the water. Oil fraction of the used motor oil and fatty acid of gossypol resin decreased coefficient of friction. Coefficient of friction is 1.15 times less than other drilling fluids that obtained by adding other lubricant as Graphite G, SMAD.

Table 1. Compositions and chemical physical properties of the developed lubricants

Lubricant composition	Physical and chemical properties					
	Density g/sm ³	Viscosity, sec	Filtration index, sm ³	Stability, g/sm ³	Coefficient of friction	pH
MGR: W: CMC: UMO	0.97	28	3	0.02	0.1228	9
MGR: W: CMC: OS	0.98	32	3	0.04	0.1228	9
MGR: W: CMC: SS	0.92	33	3	0.03	0.1228	9
SS: W: CMC	0.9	34	3	0.04	0.1228	9

Until this time in drilling operations used petroleum as a lubricant material petroleum and petroleum products have a number of significant disadvantages when used in WBM: they distort the results of geophysical research, pollute the environment, are fire-explosive and freeze at subzero temperatures. In addition, when drilling is stopped and wellbore cleaning is stopped for technical and technological reasons, lubricating additives based on oil and petroleum products migrate along the wellbore to the surface, creating sticking conditions for the bottom of the drill string. Field data has also repeatedly established that when drilling deep wells, where bottomhole temperatures are more than 150 °C, there is a decrease in the lubrication properties of oil-treated BRs. Another aspect of the use of oil and oil products in

OBM systems also has a number of significant technological limitations in terms of fire and explosion safety and environmental friendliness. The price of lubricants also will be decreased because of using industry and production wastes.

Conclusion

Research work shows that lubricants that based on modified gossypol resin and used motor have antifriction properties when application for water based drilling fluids. Coefficient of friction is less than currently used reagent as Graphite. Experiment works show that the effectiveness of lubricant additives is often increased by introducing surface-active substances (surfactants, detergents, dispersants) that ensure high colloidal solubility of fats, oils and hydrocarbons in the drilling fluids.

References

- Bulatov A. I., Penkov A. I., Proselkov Yu. M. Reference book on well flushing.— M.: Nedra, 1984.— 317 p.
- Chubik P. S. Qualimetry of the drilling flushing liquids.— Tomsk: NTL, 1999.— 300 p.
- Samota A. K. Prevention and elimination of pipe clamping during well drilling.— M.: Nedra, 1979.— 182 p.
- Pokonova Yu. V. Oil and oil products.— St. Petersburg: ANO NPO “Peace and Family”, 2003.— 904 p.
- Kobilov N. S., Khamidov B. N., Shukurov A., Kodirov S., New composition of chemicals and heavy drilling fluids for drilling oil and gas wells E3S Web of Conferences, 2023.— 401.— 05077 p. URL: <https://doi.org/10.1051/e3sconf/202340105077>.
- Kobilov N. S and oth. Study of oil sludge of oil refinery and their processing. 2023., AJTNS.,— P. 9–10. URL: <https://doi.org/10.29013/AJT-23-9.10-67-70>
- ANSI/API 13b-1. 2017. Fifth edition Recommended Practice for Field Testing Water-based Drilling Fluids. USA.

submitted 11.02.2024;
 accepted for publication 25.02.2024;
 published 18.03.2024
 © Kobilov N. S.
 Contact: nodirbekdoc@gmail.com



DOI:10.29013/AJT-24-1.2-94-97

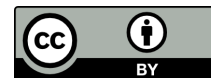

THE WAYS OF OBTAINING WEIGHTED DRILLING FLUIDS BASED ON LUBRICANTS FOR DRILLING OIL AND GAS WELLS

*Kobilov Nodirbek Sobirovich*¹

¹ Institute of General and Inorganic chemistry of Academy of sciences
of the Republic of Uzbekistan, Tashkent, Uzbekistan

Cite: Kobilov N.S. (2024). *The Ways of Obtaining Weighted Drilling Fluids Based on Lubricants for Drilling Oil and Gas Wells. Austrian Journal of Technical and Natural Sciences 2023, No 11-12.* <https://doi.org/10.29013/AJT-24-1.2-94-97>

Abstract

The article presents current state of chemical reagents, and lubricants for development and obtaining weighted drilling fluids for drilling oil and gas wells. Types and groups of weighting agents for drilling fluids are classified and their properties were studied.

Keywords: *drilling fluids, oil, gas, wells, lubricant, density, method*

Introduction

Currently in the process of building oil and gas wells to maintain the stability of the walls, to prevent the flow of salts, and to prevent the penetration of formation fluids into the well, it becomes necessary to increase the density of the drilling fluid, which can be accomplished by introducing components with increased density. A relatively small increase in density (1,1–1,2 g/sm³) is possible by adding clays (bentonite), as is often done in practice. However, this solution cannot be considered correct, since for a small increase in density it is necessary to increase the concentration of the solid phase. Drilling fluids with a density of up to 1,6–1,8 g/sm³ are obtained from sludge from carbonate and sulfate rocks (Bob De Wolfe, 2005). For obtaining and stabilization weighted drilling fluid were used powder water soluble gossypol resin and carboxymethylcellulose sodium. As weighting agents were used Okalina (waste of

metallurgical production), hematite, barite and carbonate slug. However, this increases the concentration of the solid phase, the thickness of the clay crust, a negative effect is sharply manifested differential pressure. In these cases, increasing the density more 1,8 g/sm³, barite and special weighting agents are used (Kobilov, 2012).

Materials and method

Lubricant additives volume consist of about 10–20% of all chemicals used for drilling oil and gas wells. Present time for obtaining and development of drilling fluids for drilling oil and gas wells use more than 3000 kind of chemicals in the world. Such as Carboxymethylcellulose, polyacrylamide, hydrolyzed polyacrylonitrile, ferrochrome-lignosulphonate, grafite, chrompick, NaOH, Na₂CO₃ and others. In the Republic of Uzbekistan for drilling oil and gas wells use about 2–3 thousand ton chemical reagents

every year. Domestic chemicals are not fully meet the requirements of geological and technical conditions of wells. The quality of the construction of oil and gas wells, and the quality of the opening of the productive formation, largely depends on the used drilling mud because the drilling fluid is a technological fluid that interacts with the newly opened rock. Based on the analysis of basic research in the field of chemistry and biochemistry of carbohydrates, generalizing the practice of drilling wells, polysaccharides are used as polymer reagents for regulating the filtration and rheological properties of lighted and weighted drilling fluids. The main reason for the choice of polysaccharides is their ability to chemical and biological destruction, due to which is possible to destroy and remove the formed clogging layer during the drilling process, and almost complete recovery of reservoir properties.

American Petroleum Institute (API) publishes documents relating to oilfield standards, including drilling fluids testing procedures. As with any laboratory procedure requiring the use of potentially hazardous chemicals and equipment, the user is expected to have received proper training and knowledge in the use and disposal of these potentially hazardous materials. The user is responsible for compliance with all applicable local, regional, and national requirements for worker and local health, safety, and environmental liability (Kobilov, 2023). The cost of the drilling fluid itself is relatively small in comparison to the overall cost of drilling a well, but the choice of the right fluid and maintenance of its properties while drilling profoundly influence the total well costs. For example, the number of rig days required to drill to total depth depends on the rate of penetration of the bit, and on the avoidance of delays caused by caving shale, stuck drill pipe, loss of circulation, etc., all of which are influenced by the properties of the drilling fluid. In the case of some critical wells, such as deep water operations, these excess costs can run into the millions of US dollars. In addition, the drilling fluid affects formation evaluation and the subsequent productivity of the well. The fluid also needs to be environmentally benign and generate minimal waste (Guanzheng Zhuang, 2017).

Most of global drilling operations use water-based drilling fluids, because of their lower environmental impact and lower costs. However, water-based drilling fluids are limited by their abilities of dissolving salts and interfering with the flow of oil and gas through porous rocks. Oil-based drilling fluids, owing to their excellent lubricity, high rate of penetration, shale inhibition, wellbore stability, high lubricity, high thermal stability, are expected to be used to drill difficult wells (Saborian-Jooybari, 2016).

Results and discussions

The structure, composition and physico-chemical properties of the domestic lubricants for drilling fluids, the waste of oil and fat production –gossypol resin, soap stock, oil sludge, soda ash and caustic soda, used motor oil and Na-carboxymethylcellulose “Carbonam” with 600 polymerization degree were studied.

Preparation of weighted drilling fluids by adding lubricant additive and needed weighting materials in the water necessary concentration. Concentration lubricants on the drilling fluids consist of about 2–3% and bentonite 5–10% and weighting agents 50–70%. Developed weighted drilling fluids based on lubricants for drilling in salt and high pressure layer, as they are stable to cations of polyvalent salts (Mg^{++} , Ca^{++} , Na^+ , K^+). Developed lubricant is mainly about 15–20% gossypol resin and has a high lubricity due to the content in its composition of polymerized fatty acids, pigment, glycerin and other components. These reagents as a surfactants serve to emulsify oil with water, increase drilling speed because of low coefficient of friction, play role as corrosion inhibitor.

It can be seen from testing analyses, that with a weighting of the drilling fluid of hematite up to 68–70%, the density of the solution increases to 2,35–2,44 g/cm³, and the shear stress is in the range 40–45–60 mgf/cm². The water loss values hardly change and amount to 4–5 cm³/30 min, the hydrogen index is 9. When adding barite weighting agents in an amount of 62–64%, the density of the solution is 2,11–2,21 g/cm³, while the nominal viscosity of the drilling fluid is 90–95 s and the Shear stress of the solution is 50–52 mgf/cm² for 10 min. It should be noted mineral weighting

agents, depending on the nature, are divided into carbonate, barite, glandular and galena.

Depending on the density, they are classified into 3 main groups.

Figure 1. Main technological properties of weighted drilling fluids by weightin concentration

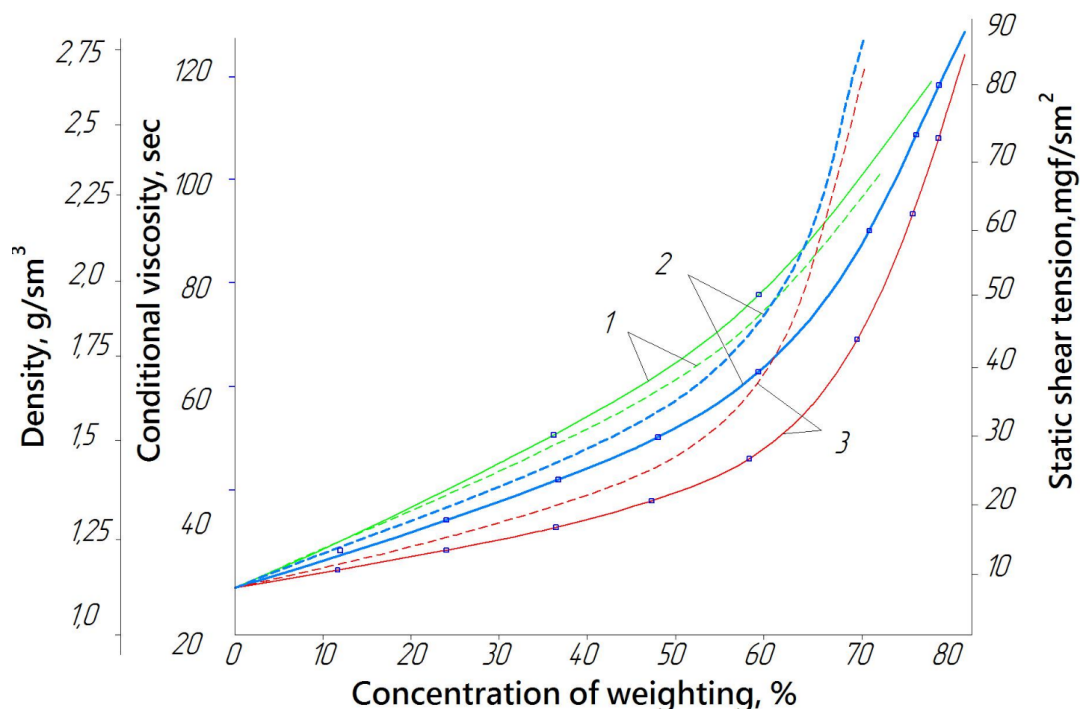

The first group of weighting agents are heavy (slightly colloidal) clays, marl, chalk, limestone, etc. These materials have a density in the range of 2,6–2,9 g/cm³ and are characterized by a relatively small structure-forming ability in drilling fluids, due to which their amount in the drilling fluid can be significant, while the rheological properties of the fluid do not deteriorate. However, the solids content in the drilling fluid increases dramatically, which adversely affects drilling efficiency.

The second group of weighting agents are materials with a density of 3,8–4,5 g/cm³, which includes barite and glandular weighting agents. These weighting agents are essential for the preparation of weighted drilling fluids. The hydrostatic pressure generated by drilling fluids with a density of 2,30–2,35 g/cm³ is sufficient for most wells. The

third group of weighting agents (with a density of 5,0–7,0 g/cm³) includes materials consisting mainly of lead and iron. These weighting agents are used to prepare drilling fluids with a density of 2,5 g/cm³ or more. Such drilling fluids are necessary for drilling deposits with cross-sectional formations with a pressure exceeding geostatic.

Conclusion

In conclusion we can inform that developed weighted drilling fluids based on lubricants have a multifunction. As a result of research and study of the physical and chemical properties of the developed weighted drilling fluids based on local and raw materials and wastes recommended for use in drilling oil and gas wells with abnormally high reservoir pressure and with difficult geological layers.

References

- Bob De Wolfe, Leon Robinson., Fred Growcock., Tim Harvey., Bob Barret., Brian Carr. 2005. Drilling fluids processing handbook. Elsevier. USA. – 666 p.
- Kobilov, N.S., Negmatova K.S., Sharifov G.N., Rakhimov X.Y. 2016. Composite chemical reagent for stabilization heavy mud for drilling salt-anhydrite layer of oil and gas wells // European applied science. II. Germany, – P. 50–52.

- Kobilov, N. S., Khamidov, B. N., Shukurov, A., Kodirov, S. New composition of chemicals and heavy drilling fluids for drilling oil and gas wells E3S Web of Conferences, 2023. – 401.– 05077 p. URL: <https://doi.org/10.1051/e3sconf/202340105077>.
- ANSI/API 13b-1. 2017. Fifth edition Recommended Practice for Field Testing Water-based Drilling Fluids. USA.
- Negmatova, K. S., Negmatov, S. S., Salimsakov, Yu. A., Rakhimov, H. Y., Negmatov, J. N., Isakov, S. S., Kobilov, N. S. 2012. Structure And Properties of Viscous Gossypol Resin Powder. AIP Conference Proceedings 1459, USA, – 300 (2012); – P. 300–302. URL: <https://doi.org/10.1063/1.4738476>
- Guanzheng Zhuang, Haixu Zhang, Hao Wu, Zepeng Zhang, Libing Liao. Influence of the surfactants' nature on the structure and rheology of organo-montmorillonite in oil-based drilling fluids. J. Applied clays Science – 135. (2017).– P. 244–252. URL: <http://dx.doi.org/10.1016/j.clay.2019.09.33>
- Komila Negmatova, Shodilbek Isakov, Nodir Kobilov, 2012. Effective Composite Chemical Reagents Based On Organic And Inorganic Ingredients For Drilling Fluids Used In The Process Of Drilling Oil Wells // Advanced Materials Research. Trans Tech Publication, Switzerland. – Vol. 413 – P. 544–547.
- Saborian-Joybari, H., Dejam, M., Chen, Z. Heavy oil polymer flooding from laboratory core floods to pilot tests and field applications: Half-century studies. J. Pet. Sci. Eng. 2016.– 142.– P. 85–100. URL: <http://doi: 10.1016/j.petrol.2016.01.023>

submitted 13.02.2024;
accepted for publication 29.02.2024;
published 18.03.2024
© Kobilov N. S.
Contact: nodirbekdoc@gmail.com

Contents

Section 1. Agriculture

- Yuldashev Gulom, Mamajonov Inomzhon Noralieovich,
Makhramkhuzhaev Sul-tonkhuzha Akramkhuzha*
BIOGEOCHEMISTRY OF ZINC IN IRRIGATED SOILS
OF THE DESERT ZONE 3

Section 2. Biology

- Ramazanov Medetbay Baxitbaevich*
THE INFLUENCE OF ENVIRONMENTAL FACTORS ON THE
HEALTH OF STUDENTS AT ACADEMIC LYCEUMS IN THE
REPUBLIC OF KARAKALPAKSTAN..... 8

Section 3. Chemistry

- Baymuratova G. O', Saitkulov F. E.*
STUDYING THE REACTION OF BAP WITH SUCCINIC ACID
AND ITS EFFECT ON THE ROOTING OF THE SEEDLING OF
THE VARIETY "BUKHARA-102" 13

- Kurbonkul Karimkulov, Ikromjon Uzahkov, Muzaffar Karimkulov*
CHEMICAL COMPOSITION AND CLASSIFICATION
OF CHEWING GUM ACCORDING TO COMMODITY
NOMENCLATURE FOREIGN ECONOMIC ACTIVITY THE
REPUBLIC OF UZBEKISTAN 19

- Artikbaeva Baxtibike Rasbergenovna,
Naubeev Temirbek Khasetullaevich*
CYCLOASCIDOSIDE D FROM *ASTRAGALUS MUCIDUS*..... 24

- Saitkulov Foziljon Ergashevich, Elmuradov Burkhon Zhuraevich,
Sapaev Bayramdury*
SYNTHESIS AND BIOLOGICAL ACTIVITY OF HYDROCHLORID
QUINAZOLIN-4-ONE 28

- Eshkurbonov Furkat Bozorovich, Rakhimov Alisher Khudaikulovich,
Safarova Ezozxon Ramazon kizi, Ashurova Asal Abdualim kizi*
INVESTIGATION OF THE CHEMICAL–MINERALOGICAL
COMPOSITION OF BENTONITE OF THE KHAUDAG DEPOSIT
AND SYNTHESIS OF WINE FINING AGENTS BASED ON ITS 36

Section 4. Food processing industry

- Akhmedov Azimjon Normuminovich,
Ishankulova Gavxar Norkulovna, Umirova Zilola Sherali kizi*
ANALYSIS OF OILS OBTAINED BY THE PRESSING METHOD
FROM FRUIT GRAINS 44

*Akhmedov Azimjon Normuminovich,
Karbonova Oftoboyim Khusniddinovna,
Abdullaev Asadulla Shokir ugli, Kurbanov Mukhammadali Akhmad ugli*
RESULTS OF EXTRA HIGH FREQUENCY RADIATION
TREATMENT OF COTTON SEED..... 48

Section 5. Light industry

Azamat Ktaybekov
ECONOMIC TRANSFORMATIONS IN THE INDUSTRY OF THE
REPUBLIC OF KARAKALPAKSTAN IN THE SECOND HALF OF
THE 90S OF THE XX CENTURY 53

Section 6. Technical science in general

Makhmudov M. J., Elmurodov E. Yu.
STUDY OF THE PROCESS OF DRYING NATURAL GAS USING
GLYCOLS USING MULTIFUNCTIONAL ADDITIVES AND
AZEOTROPIC SOLVENTS 58

Makhmudov M. J., Elmurodov E. Yu.
THE MAIN DIRECTIONS OF NATURAL GAS PROCESSING IN
THE CHEMICAL INDUSTRY..... 63

Ergashev Sirojiddin Fayazovich, Khudoyorov Khayotjon Dilshodjon ogli
ANALYSIS OF CATHODIC PROTECTION STATION WITH THE
FUNCTION OF SEARCHING FOR THE MAXIMUM POWER
POINT OF A PHOTOVOLTAIC MODULE 68

Ergashev Sirojiddin Fayazovich, Oshepkova Elvira Axtemovna
ANALYSIS OF CALCULATING THE POSITION OF THE SUN
OVER CITIES OF THE REPUBLIC OF UZBEKISTAN 73

*Saidkhodzhaeva Dildora Olimjon's daughter,
Choriev Abusattar Jo'rayevich, Usmonzhonova Khulkar Umarqulovna,
Akramova Rano Ramzitdinovna, Baltabaev Ulugbek Narbaevich*
RESEARCH OF TECHNOLOGY FOR EXTRACTION OF
COLORING SUBSTANCES FROM AMARANTH FLOWERS..... 79

Makhmudov Mukhtor Dzhamolovich, Yomgirov Sardulla Ataboy u gli
SELECTION OF A METHOD FOR PREPARING NATURAL GAS
FOR TRANSPORTATION BY MAIN GAS PIPELINES 85

Kobilov Nodirbek Sobirovich
DEVELOPMENT OF EFFECTIVE LUBRICANTS FOR DRILLING FLUIDS.... 90

Kobilov Nodirbek Sobirovich
THE WAYS OF OBTAINING WEIGHTED DRILLING FLUIDS
BASED ON LUBRICANTS FOR DRILLING OIL AND GAS WELLS..... 94