



DOI:10.29013/AJT-26-3.4-195-202



MODULAR SYSTEM ARCHITECTURE FOR REGENERATION AND RECIRCULATION OF PROCESS FLUIDS. (Modular system architecture for regeneration and recirculation of process fluids, including water and aqueous solutions)

*Volodymyr Ikonnikov*¹

¹ Independent Researcher Odesa, Ukraine

Cite: *Ikonnikov V. (2026). Modular system architecture for regeneration and recirculation of process fluids. (Modular system architecture for regeneration and recirculation of process fluids, including water and aqueous solutions). Austrian Journal of Technical and Natural Sciences 2026, No 3 – 4. <https://doi.org/10.29013/AJT-26-3.4-195-202>*

Abstract

This article examines existing industrial methods for the treatment of water contaminated by technological processes and production waste, including chemical reagent-based treatment methods, non-reagent purification methods, and combined treatment technologies. Particular attention is devoted to the analysis of the limitations of current approaches and their inability to fully satisfy the growing technological, environmental, and economic requirements of modern industrial production. The article substantiates the necessity of implementing a comprehensive integrated approach to industrial wastewater treatment and presents an innovative integrated technology incorporating recent developments in the field. The proposed technology is structured as a sequence of functionally interconnected yet technologically independent treatment stages, each based on distinct physical and chemical principles. The study emphasizes that contemporary challenges in water treatment and water conditioning can no longer be effectively resolved through isolated or partially combined conventional methods. It is concluded that only a comprehensive multi-stage treatment approach can meet the increasingly stringent demands of modern industrial systems and ensure effective, scalable, and technologically adaptable wastewater treatment solutions.

Keywords: *Water treatment methods; Water and aqueous solutions; Chemical reagent-based treatment; Non-reagent treatment and purification; Combined treatment methods; Integrated technologies*

Introduction

In combination with recent innovative concepts proposed and published by leading specialists, particularly Vladyslav Drapiy, the author introduces an integrated techno-

logical approach that can be implemented through a system of complete, autonomous, and standardized technological modules, configured as follows:

Figure 1. Nine principal modular technological configurations encompassing all processing stages and operations required for the formation of a modular technological equipment complex intended for the purification, regeneration, and recirculation of process fluids, including water and aqueous solutions

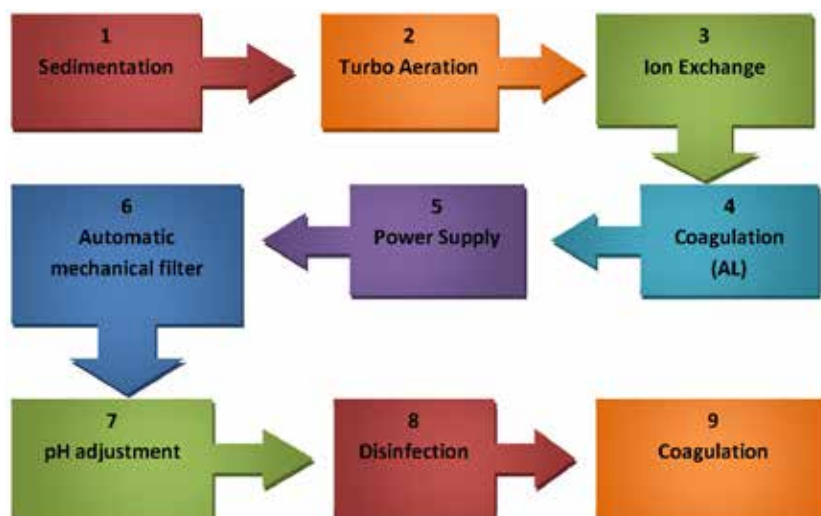

Among the presented modules, **Module 5 – the power supply unit** is relatively universal, whereas the remaining eight modules have more specialized application areas:

- **Module 1 – Sedimentation module**, which may be designed as a sedimentation column or as a sedimentation tank with a parallelepiped configuration;
- **Module 2 – Turbo-aeration module**, which may have at least two configurations: one utilizing foam generators and another employing a system for mixing and in-line homogenization;
- **Module 3 – Ion-exchange treatment module**, which may have multiple configurations, one of the most effective being based on ion-exchange columns equipped with capsules for ion-exchange resins made from carbon–carbon composite fabrics;
- **Module 4 – Coagulation module**, utilizing aluminum ions as a coagulant, generated in electrochemical reactors with aluminum anodes;
- **Module 6 – Automatic mechanical filtration module**, incorporating automated cleaning of filtration sections and in-line regeneration of filtering elements;
- **Module 7 – pH adjustment module**, intended for regulating acidity and alkalinity;

- **Module 8 – Electrochemical non-reagent disinfection module;**
- **Module 9 – Final electrochemical coagulation module.**

As shown in the diagram, the system inlet is equipped with a receiving tank incorporating several elements that enable preliminary treatment of process fluid that has completed its operating cycle. This initial treatment is performed using a membrane filter connected via a check valve to an inlet pump, which feeds the fluid to a primary sedimentation column. Depending on the flow rate, the sedimentation column may consist of one, two, or three sections.

After the first stage of sedimentation, the fluid is directed to electrochemical reactors for pH adjustment (acidity or alkalinity), which are controlled and powered by a multifunctional power supply unit.

Following pH adjustment, and in order to establish alkaline conditions optimal for efficient sedimentation, the fluid is transferred to a specialized sedimentation module with a specific geometry designed to facilitate the separation of formed sedimentation conglomerates within an upward flow.

Upon completion of the sedimentation process, the fluid, based on a level sensor signal, is delivered by a centrifugal pump to mechanical filtration modules, where residual conglomerate particles that were not captured within the sedimentation layer are removed.

Figure 2. Example of a modular system configuration for the regeneration of process fluids, including water and aqueous solutions

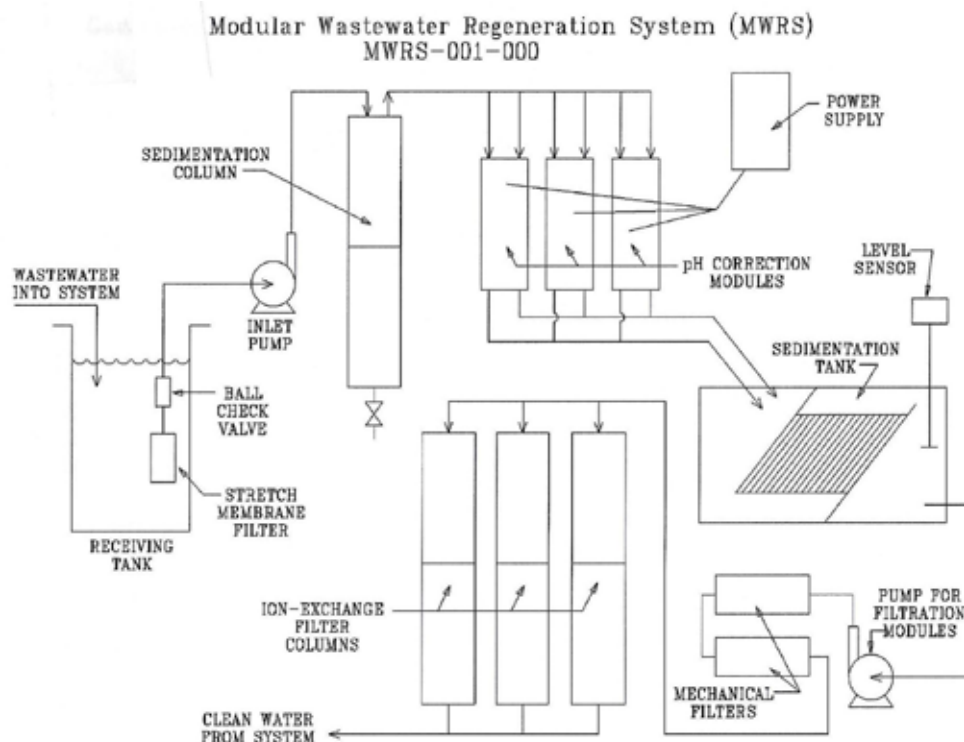

Since the mechanical filters operate in an in-line (continuous) mode, the pressure generated by the filtration pumps is sufficient to feed the fluid, after mechanical filtration, directly into the ion-exchange treatment columns.

Based on the findings and proposals presented in the publications and patent applications of Vladyslav Drapiy, as well as his multifunctional forecast regarding the development of environmentally sustainable technological systems, the author of the present publication has significantly expanded the technical capabilities of ion-exchange treatment columns, which warrants further detailed consideration.

It is particularly important to note that, for ion-exchange treatment, not only synthetic ion-exchange resins should be used, but also natural materials, among which zeolite represents one of the most effective options.

Under the modular design concept for ion-exchange columns proposed by Vladyslav Drapiy – where a column consists of at least two modular sections – it becomes possible to utilize multiple ion-exchange materials with different exchange capacities within a single column. For example, zeolite may be applied in the upper section, while synthetic ion-exchange resin may be used in the lower section.

The combination of these materials ensures optimal performance in purification, regeneration, and recirculation processes.

This modular system configuration is conceptually aligned with the inventions and developments of Vladyslav Drapiy, a recognized innovator in the field of non-reagent, high-efficiency, real-time treatment of liquids, including water and aqueous solutions, in directed flow systems.

Practical implementation has demonstrated that the hierarchical system of specialized yet autonomous technological modules proposed by Vladyslav Drapiy – each possessing a distinct technological function, an independent operational cycle, and requiring no chemical reagents or synthetic activating additives – enables the formation of higher-level modules from lower-level components within a fully efficient economic and technological framework.

Moreover, the absence of introduced chemical reagents allows for the immediate initiation of continuous (in-line) recirculation processes following the completion of regeneration operations, while maintaining a high level of quality of process fluids and solutions.

Figure 3. A modular system with an intermediate module incorporating a pre-filter at the inlet and a series of mechanical filters at the outlet of the intermediate module, upstream of the electrochemical reactors for pH adjustment (acidity and alkalinity)

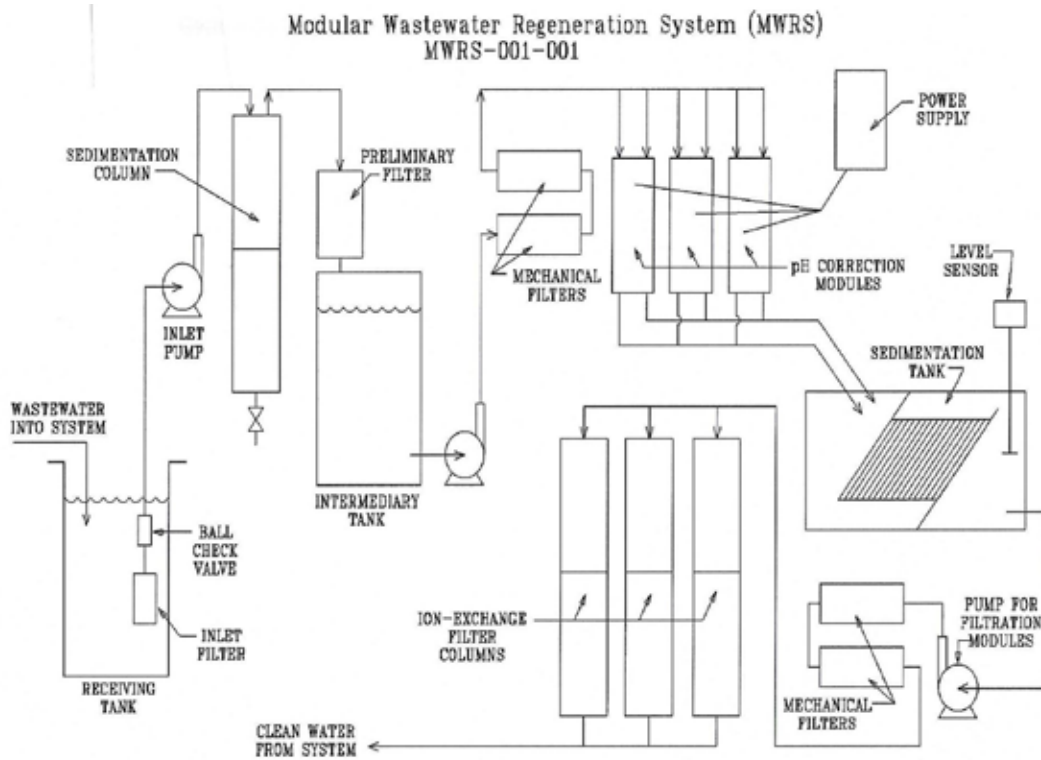
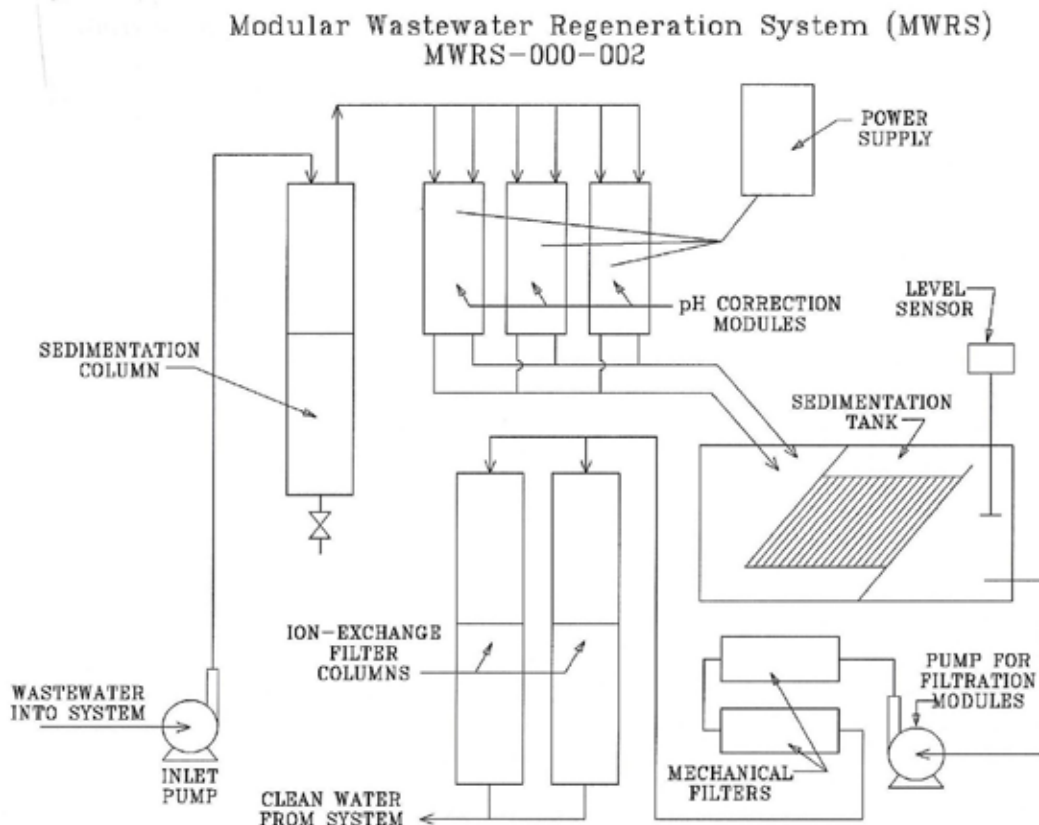

Figure 4. The most compact modular system configuration without intermediate technological or structural elements



Thus, as demonstrated by the presented figures and diagrams, the hierarchical structure of vertically integrated modular systems enables the simultaneous resolution of technological and environmental challenges while meeting the needs of industrial operations of any type and level of waste contami-

nation, ensuring full regeneration and subsequent recirculation of process fluids.

Furthermore, this approach contributes to addressing the transformation of industrial systems of varying scales and degrees of organizational flexibility into so-called smart manufacturing systems.

Figure 5. Basic IP

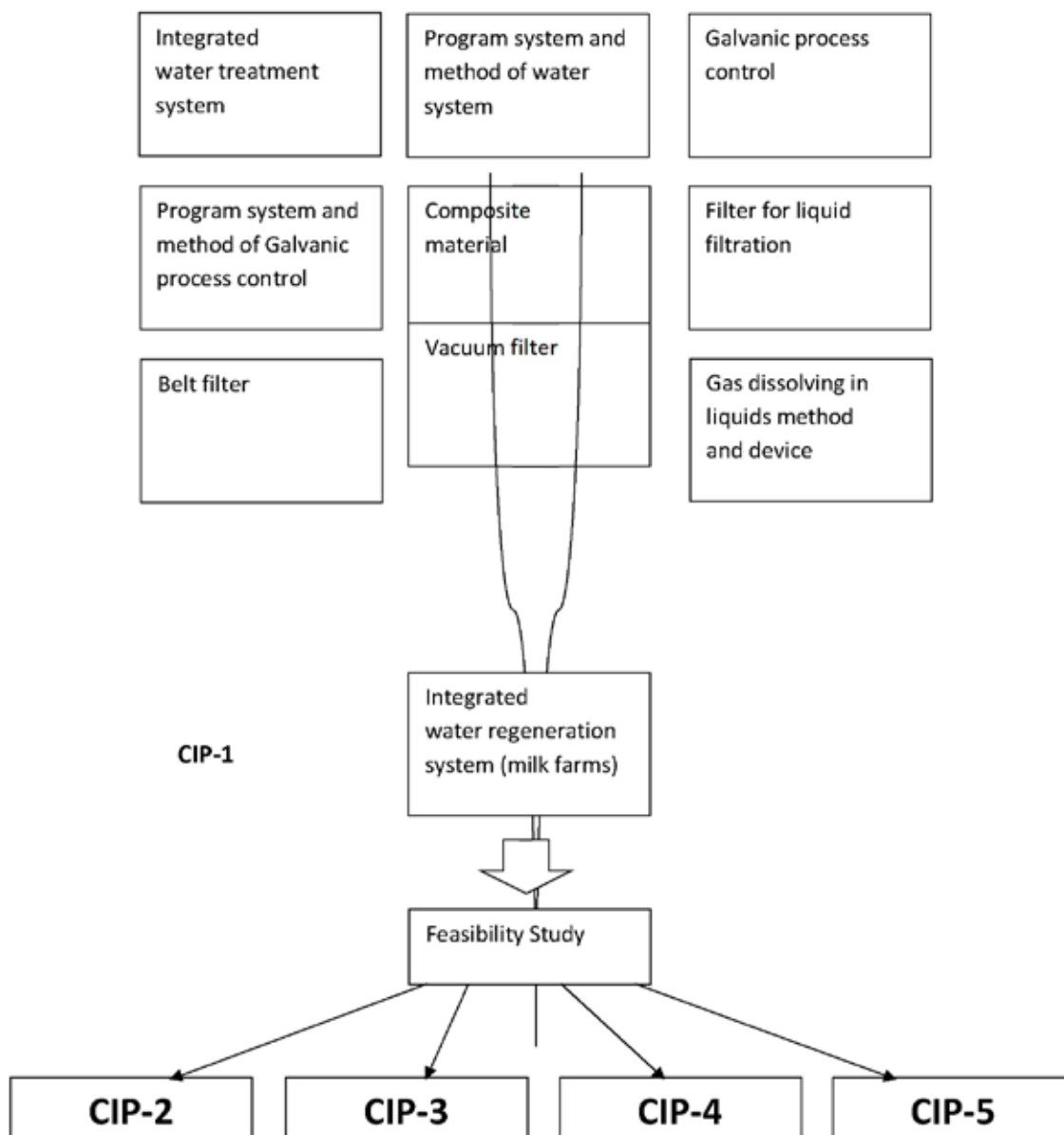

As shown in the presented algorithmic diagram, which is also developed based on innovative concepts and proposals derived from the inventions and publications of Vladyslav Drapiy, a total of **14 objects** are identified and represented. Each of these objects constitutes a complex of modules composed of autonomous modules of a lower combinatorial level.

Each of the presented modules represents an independent subject of patent protection, and all possible combinations of these modules likewise constitute full subjects of patent protection and valid objects for further patent continuation (in accordance with applicable U.S. patent law).

As of today, users of water treatment technologies face a number of challenges that

prevent auxiliary water treatment operations from achieving the same level of efficiency as primary industrial processes. The key challenges include:

- continuous limitations in available water resources suitable for technological processes;
- ongoing deterioration in the quality of natural water resources;
- steadily increasing cost of water resources;
- increasingly stringent regulatory standards for wastewater discharge, leading to higher treatment costs;
- continuously rising requirements for the quality parameters of process water;

- the introduction of new synthetic and organic materials in modern production processes, requiring continuous modernization of water treatment systems or significantly expanded operational capabilities, resulting in increased capital and operational costs;
- the existence of numerous industrial facilities operating with outdated equipment that has reached the end of its service life, where replacement is either economically burdensome or technically unfeasible.

Figure 6. *Integrated water treatment technology*

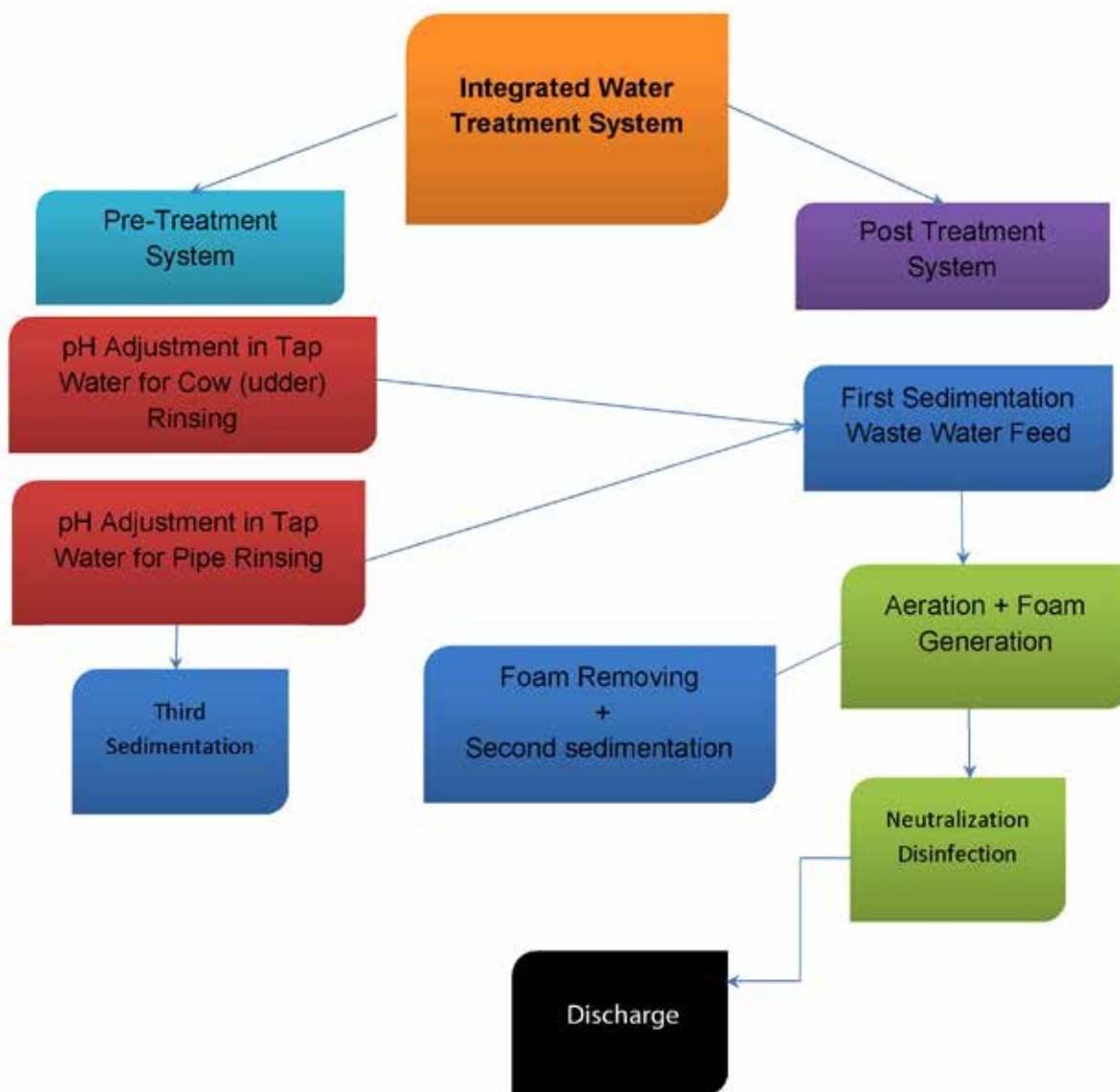

Patent and Licensing Landscape and Patentability of the Proposed Technologies

Based on preliminary analysis and patent searches related to the proposed water treatment methods, the following subject areas have been identified for patent applications:

- a комплекс of modules for advanced treatment of water and aqueous solutions, and an associated method of use;
- a comprehensive water treatment method and technological modules for its implementation;
- a method for electrolytic extraction of metals from water or aqueous solutions, and electrode cells for its implementation;
- a method for aerodynamic foaming of water in a continuously moving flow, and a foam generator for implementing the method;
- an integrated method of filtration combined with ion-exchange treatment and biosorption;
- an electrode cell for electrocoagulation with coaxial electrodes;
- an electrode cell for electrocoagulation with a continuously moving belt cathode;

- an electrode cell for pH adjustment (acidity/alkalinity) using blocks of polarizable soluble electrodes;
- an electrode cell for pH adjustment using volumetric porous electrodes;
- an electrode cell for pH adjustment using continuously moving belt electrodes;
- an electrode cell for electrochemical disinfection, and associated electrode systems for implementation.

For each patent application, prototypes and analogs have been identified based on the developments and inventions of Vladyslav Drapiy, the author of the proposed methods. Based on the results of the preliminary patent search and structural analysis, the full patentability of the above technical solutions has been established.

Based on the foregoing, it becomes possible – through the integration of vertically structured modular systems – to develop a block diagram of an integrated technological complex in which the flexibility and selectivity of each process are addressed at the level of individual modules within the lowest tier of the hierarchical structure.

References

US Patent Application 20100224506

Process and Apparatus for Complex Treatment of Liquids.

United States Patent Application, September 9, 2010.

US Patent Application 20100224497

Device and Method for the Extraction of Metals from Liquids.

United States Patent Application, September 9, 2010.

US Patent Application 20110069579

Fluid Mixer with Internal Vortex.

United States Patent Application, March 24, 2011.

US Patent Application 20100193445

Foaming of Liquids.

United States Patent Application, August 5, 2010.

US Patent Application 20150130091

Foaming of Liquids.

United States Patent Application, May 14, 2015.

US Patent 6,139,714

Method and Apparatus for Adjusting the pH of a Liquid.

United States Patent, October 31, 2000.

US Patent 9,144,774

Fluid Mixer with Internal Vortex.

United States Patent, September 29, 2015.

submitted 15.04.2026;
accepted for publication 29.04.2026;
published 30.04.2026
© Ikonnikov V.
Contact: v.drapii@legarithm.io